



## **Sachs 48mm Open Cartridge Fork Service Manual**

**Removing the fork components and reassembly including  
lowering 2019 SFF Fork and 2012-18 standard fork.**

### CONFIDENTIALITY NOTICE

This message (including any attachments) contains information that may be confidential and is for authorized Beta Dealer's use only.

7-2019

Work must be performed by trained technician.  
Beta USA, Inc.

## Table of Contents

Introduction / Special Tools .....	Page 2
2019 Fork Diagram and Component Description.....	Page 3-4
2012-2018 Fork Diagram and Component Description.....	Page 5
19' RH (Spring side) Fork Cap Disassembly.....	Page 6
2012-19' LH (Dampening) Fork Cap Disassembly.....	Page 7
2012-2019 Fork Internal Disassembly.....	Page 8-12
2012-2019 Fork External Disassembly.....	Page 13
2012-2019 Fork External Assembly.....	Page 14-16
2012-2019 Fork Internal Assembly.....	Pages 17-23
2012-2019 Fork Lowering Spacer Procedure.....	Pages 24-26

# Introduction

The Sachs 2012-18 fork utilizes an open cartridge fork technology. The oil within the cartridge and outside is the same. The cartridge is at the bottom of the fork and remains under the oil at all times. The oil circulates throughout the cartridge, as there is one common oil chamber.

**2019 Model:** The SFF or Single Function Fork refers to each fork having a specific duty, the right fork has the spring preload and compression dampening and the left handles the rebound dampening. Both fork internal components look very similar but some are specific to one side or the other, therefore it is advised not to combine them during cleaning.

The procedures in this manual must take place in a clean environment using professional and some specific tools.

Use caution not to damage the surface of the fork tubes, cartridge, rod, or any other suspension components.

When using a the bench vise, always use protective jaws made from brass, aluminum or plastic. Always clean suspension components before assembly, using appropriate solvents and lint free towels to prevent contamination. Replace common wear parts such as seals, gaskets, bushings and O-rings every service interval.

## CAUTION:

Always wear protective eyewear, gloves and appropriate clothing.

Before you perform any maintenance, be sure to read and carefully follow the detailed instructions described in this manual.

Incorrect disassembly/assembly of the fork may cause serious damage, injury, or death to the rider and property.



## Special tools

1. Cartridge rod holding tool
2. 17mm low torque wrench
3. 19 mm low torque wrench
4. 26mm wrench
5. Cartridge holding clamp for vise
6. Cartridge rod holding clamp for vise
7. 48mm seal driver
8. 48mm seal bullet
9. Fork cap wrench
10. Measuring beaker

## 2019 Left Fork Diagram and Component Description

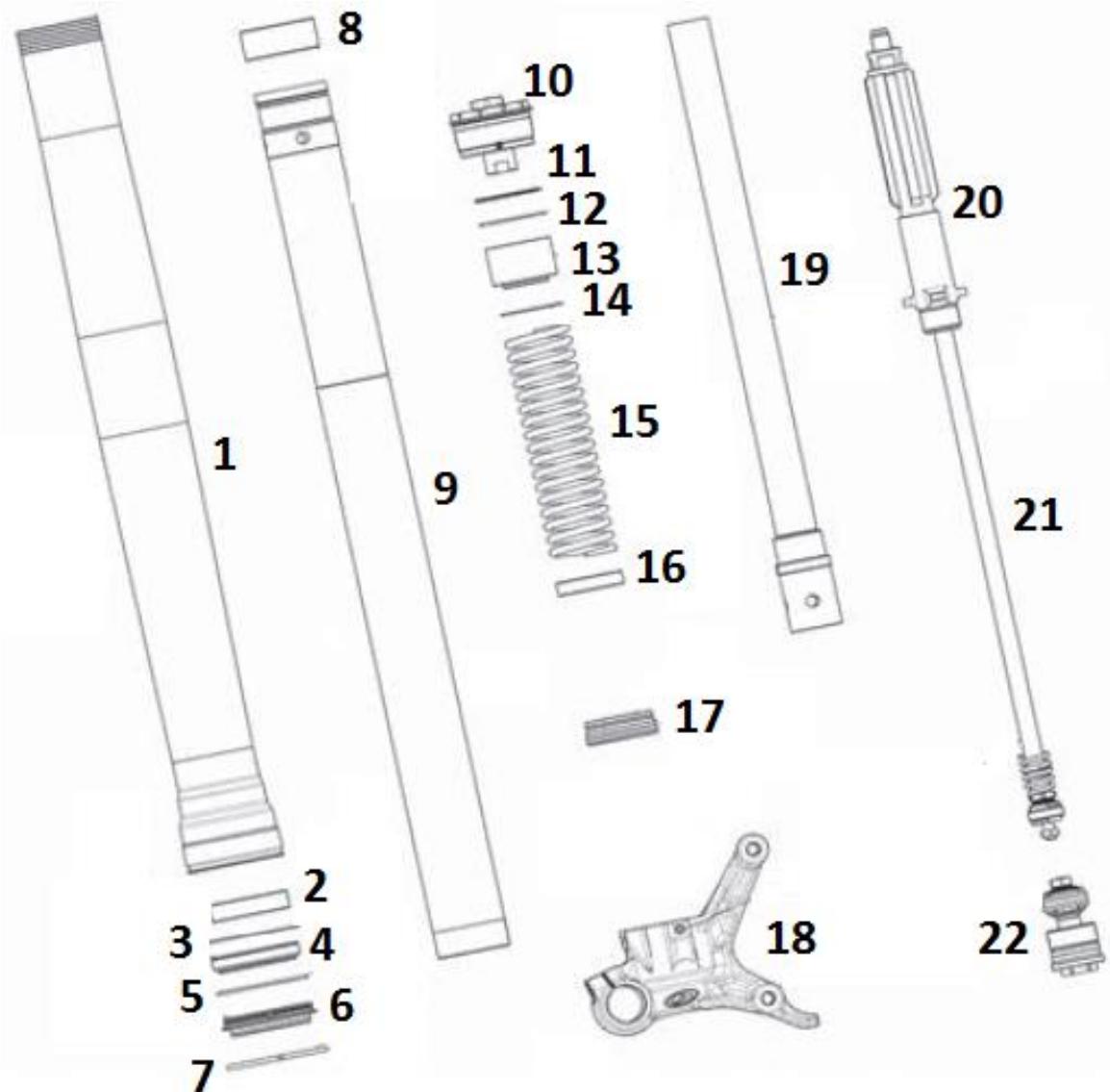

1. Outer fork tube
2. Bottom guide bushing
3. Oil seal support washer
4. Fork oil seal
5. Retainer circlip
6. Dust seal
7. Outer tube wear ring
8. Top slide bushing
9. Inner fork tube
10. Fork Cap - Rebound
11. Steel Washer

12. Washer w/Teflon
13. Preload spacer
14. Thin steel washer
15. Coil spring
16. Aluminum Spring seat
17. Cylinder support collar
18. Left axle lug
19. Cartridge cylinder
20. Spring guide
21. Cartridge rod
22. Compression assembly

## 2019 Right Fork Diagram and Component Description

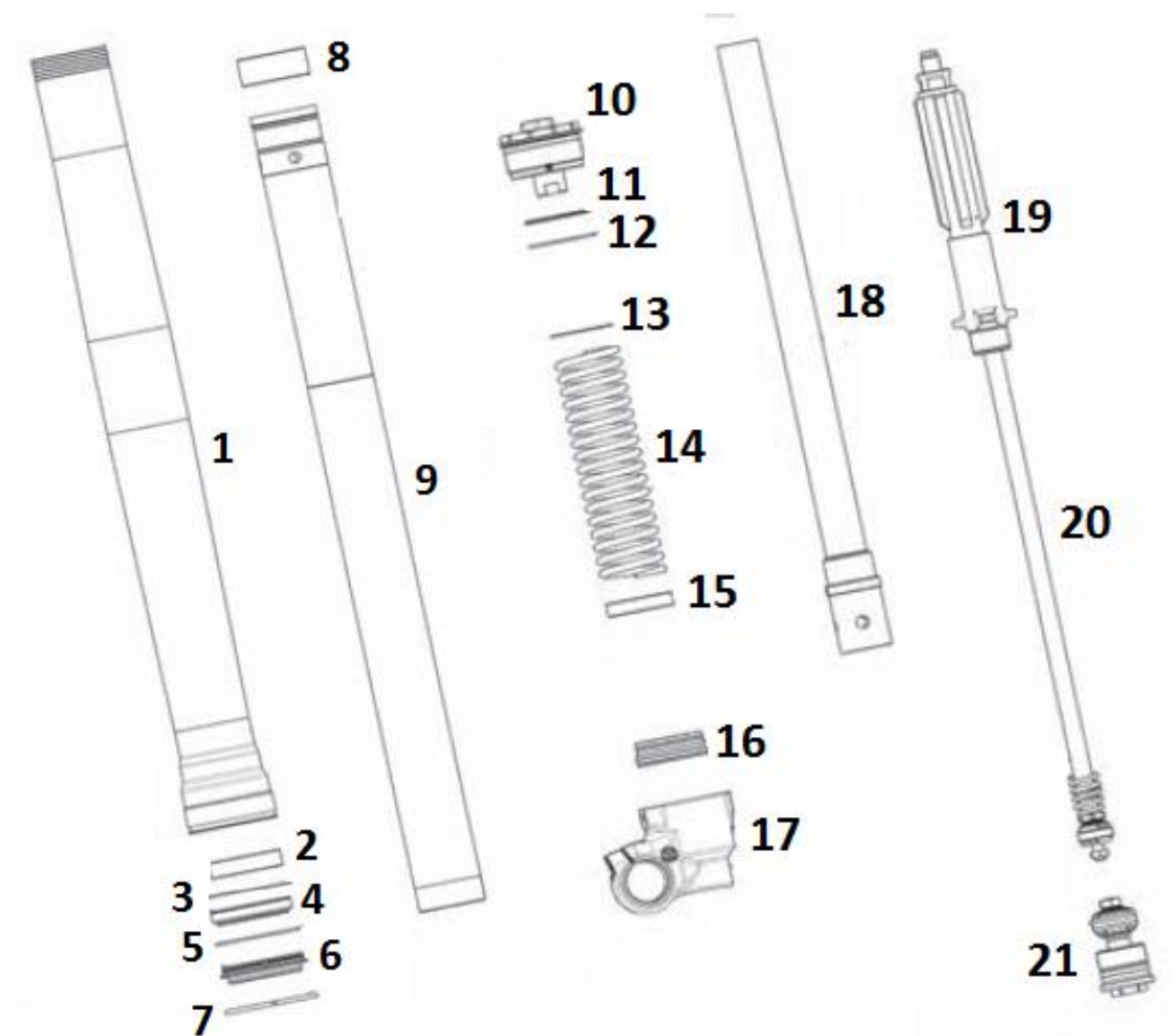

1. Outer fork tube
2. Bottom slide bushing
3. Oil seal support washer
4. Fork oil seal
5. Retainer circlip
6. Dust seal
7. Outer tube wear ring
8. Top guide bushing
9. Inner fork tube
10. Fork Cap – Compression / Preload
11. Steel Washer

12. Washer w/Teflon
13. Thin steel washer
14. Coil spring
15. Spring seat
16. Cylinder support collar
17. Right axle lug
18. Cartridge cylinder
19. Spring guide
20. Cartridge rod
21. Compression assembly

## 2012-18 Fork Diagram and Component Description

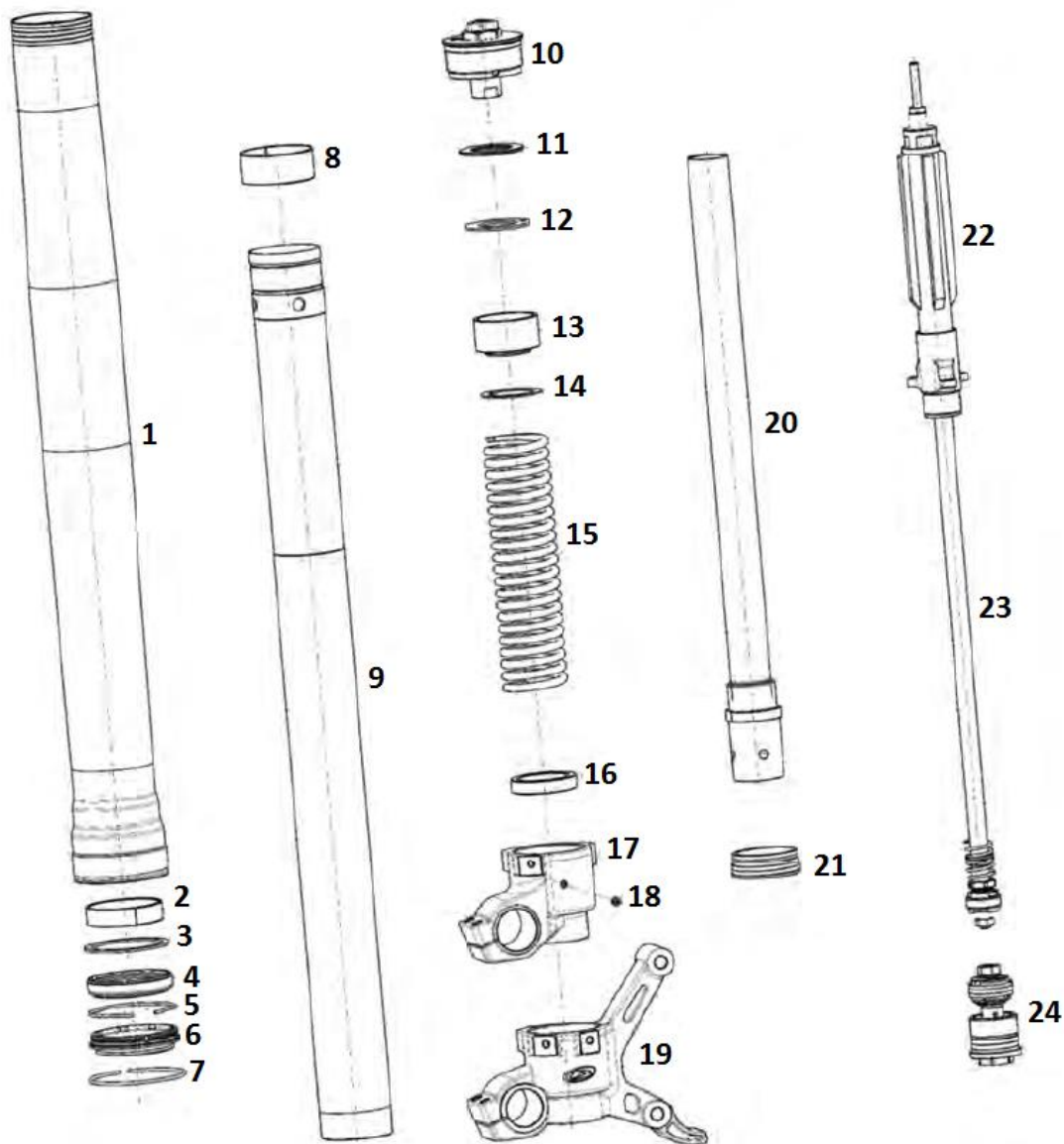

1. Outer fork tube
2. Guide bushing
3. Oil seal support washer
4. Fork oil seal
5. Retainer circlip
6. Dust seal
7. Outer tube wear ring
8. Slide bushing
9. Inner fork tube
10. Fork cap
11. Steel washer
12. Washer w/ Teflon

13. Preload spacer
14. Thin steel washer
15. Coil spring
16. Spring seat
17. Right fork lug
18. Set screw
19. Left fork leg
20. Cartridge cylinder
21. Cylinder support collar
22. Spring guide
23. Cartridge rod
24. Compression assembly



## 2019 Right Fork Cap Disassembly

### Compression and Spring Preload

*\*Note the adjustment settings then back out all adjusters completely.*



Place a dot on the bottom of the right compression fork for identification.

Secure the fork in a soft jaw vise and loosen the cap from the outer fork with the 10Pt. wrench (AB-15021).



Pull downward on the fork spring and insert a 19mm low torque (thin) wrench onto the spring guide nut. Next, insert a 17mm low torque wrench above the spring guide nut, located on the lower part of the fork cap.

Holding the 19mm wrench, turn the 17mm wrench counter clockwise to break free the fork cap from the spring guide nut.



2019 Right Fork Cap (Compression/Preload)  
\* Shown in photo

## 2012-2019 Left Fork Cap Disassembly

### Rebound Dampening

*\*Note the adjustment settings then back out all adjusters completely.*

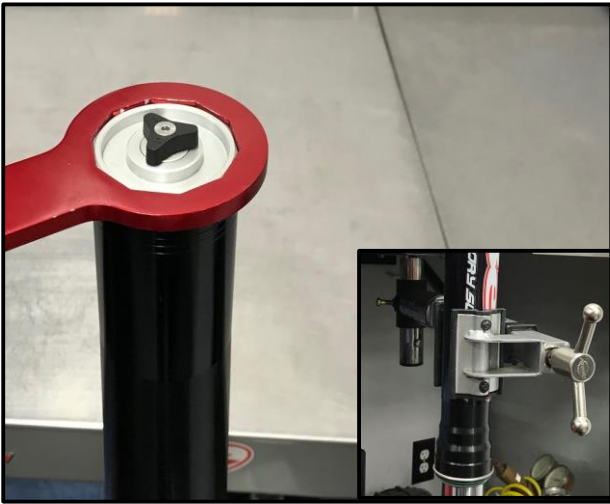

Secure the fork in a soft jaw vise or Park tool and loosen the cap from the outer fork with the 10Pt. wrench (AB-15021).



Pull downward on the fork spring and insert a 19mm low torque (thin) wrench onto the spring guide nut.

While holding the spring guide jam nut with the 19mm wrench, loosen and remove the fork cap with the 10pt. fork cap wrench.

***2012-18 Fork Cap/Rebound adjuster uses a 24mm hex and a 19mm spring guide jam nut on both forks.***



2019 Left Fork Cap (Rebound)

\* Shown in photo

2012-18 spacer and washer(s) orientation will vary from year to year. Note in disassembly.



## 2012-2019' Fork Internal Disassembly



Remove the spring.



Drain the fork oil.



Remove the rebound adjuster rod.

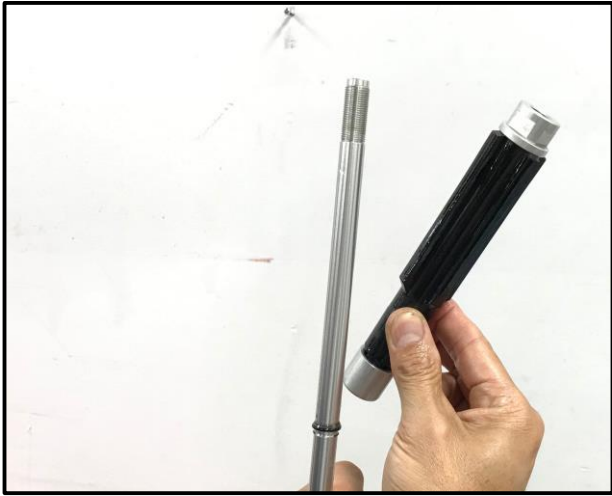

Remove the spring guide.



**Note:** Inspect the spring guide and O-ring if applicable for damage. If spring guide is broken, the spring guide is available from the 2019 RR-S parts diagram.

- \* 2012-18'
- \* 2019

O-ring not applicable  
O-ring applicable

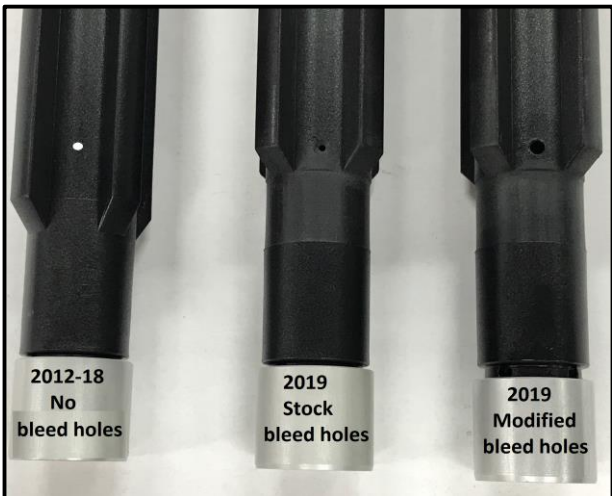

The 2019 spring guide comes with two small bleed holes. It is recommended to enlarge the holes to 3mm.

This is also recommended for older models without bleed holes. Drill at minimum, one 3mm bleed hole to prevent spring guide failure.

**2019 models:** If the O-ring is damaged, it can be removed if the 3mm enlarged holes are implemented.



Remove the aluminum spring seat collar using a long pick, before inserting the cartridge holding tool.

Next, insert the cartridge holding tool (AB-15019).

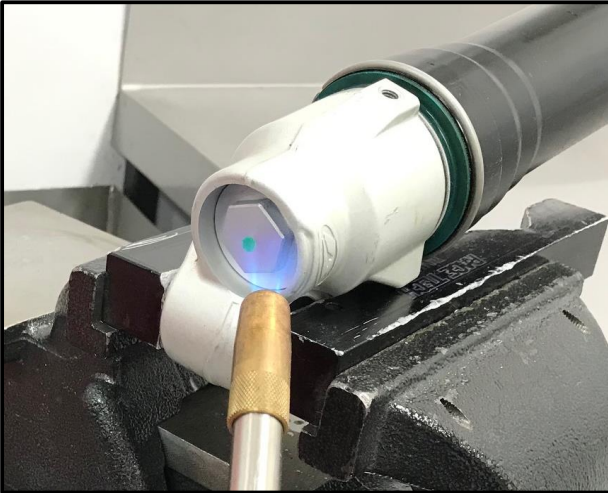

Apply heat with a torch, or heat gun for approximately 45 seconds to loosen the factory thread locking agent.

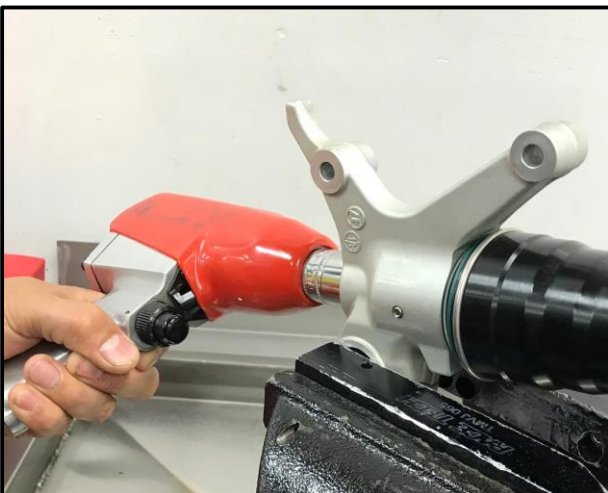

While applying downward pressure with the cartridge holding tool, use an impact wrench with appropriate socket, or Allen to loosen the compression assembly.



Caution when removing the compression assembly, as the assembly will be hot to the touch.

Note: The 2012-18 compression assembly has an adjuster screw located on the bottom and is not specific to one side.



Remove the cartridge assembly from the outer fork external assembly.

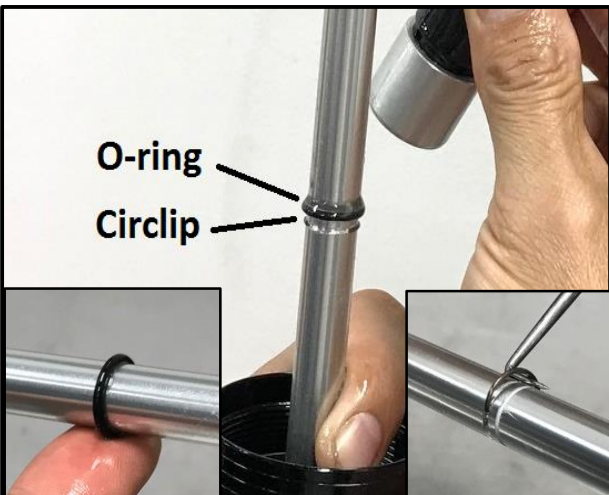

Remove the O-ring and circlip from the cartridge rod.

\* 2012-18 don't have the O-ring and much older years can have an oil lock assembly pressed onto the cartridge rod instead of a circlip.





Remove the cartridge rod from cartridge cylinder.

Clean and inspect all parts.

**Note: FOR FORK LOWERING, now proceed to pages BLAHHHHHHHHHHH**



**Note:** The 2019 compression cartridge cylinder has holes and the rebound side doesn't.



**Note:** The 19' rebound rod assembly have delta valve shims located on the top of the valve to indicate the rebound side. **\* All 2012-18 cartridge rods will have delta valve shims located on top of valve and is not specific per side.**

The 19' compression rod assembly has one check shim and spring located on top of the valve.

## Fork External Disassembly

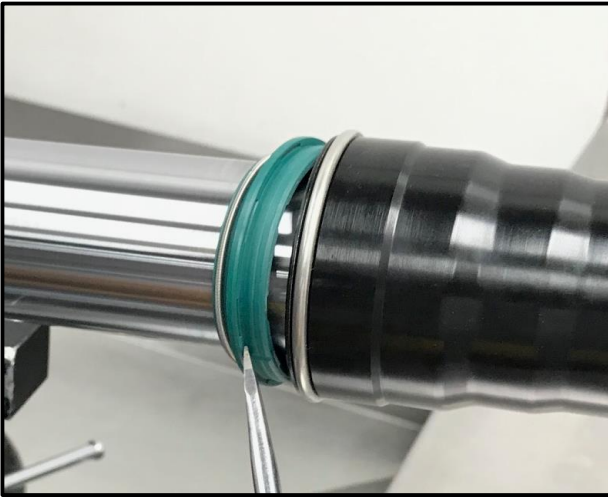

Lightly pry the fork dust seal to unseat it from the outer fork tube.



Remove the oil seal circlip with a pick.

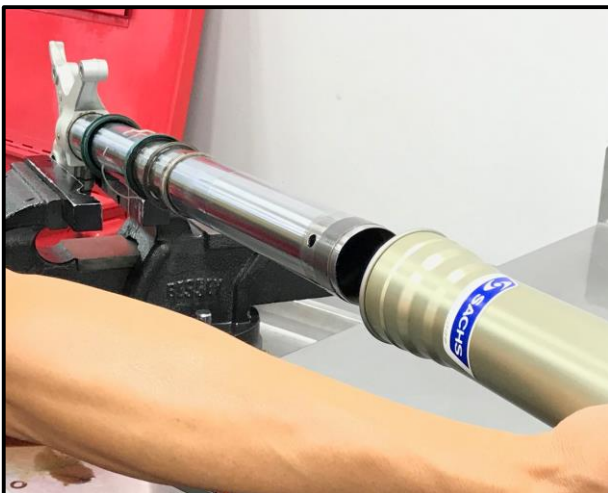

Using a bench vice to secure the fork. With one quick motion, pull the tubes apart.

Remove the bushings, oil seal washer, oil seal, retaining circlip and dust seal. Pay close attention to the order of removal and orientation.

Clean and inspect all components, replace all common wear parts.



## Fork External Assembly



Use 600 grit wet/dry sandpaper with a twisting motion back and forth to clean up any nick's, or burrs on the outside of the inner fork tube.



Apply grease to the inside edge of the new dust seal and inner and outer edge of the new oil seal.

Using a 48mm fork seal bullet, first install the dust seal, circlip , oil seal and support washer paying attention to orientation.

The spring side of the dust seal should face down and the groove on the oil seal should face up.



Remove the seal bullet and install the new slide and guide bushings.

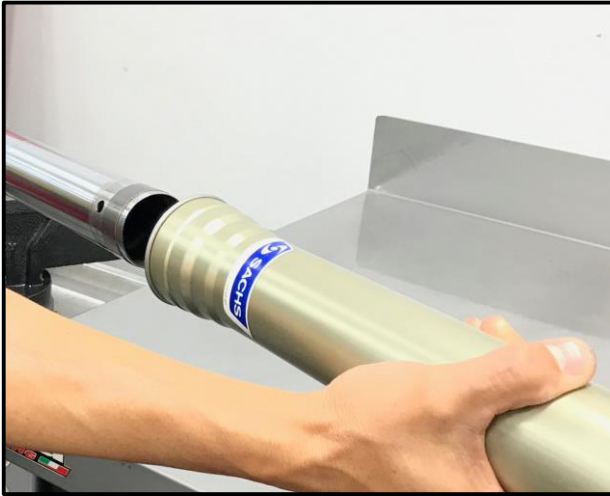

Slide the outer fork tube over the slide bushing, located on the inner tube.



Using a 48mm seal driver, slide the support washer against the slide bushing to install it into the outer fork leg.



Use the 48mm seal driver to insert the oil seal into the outer fork leg.

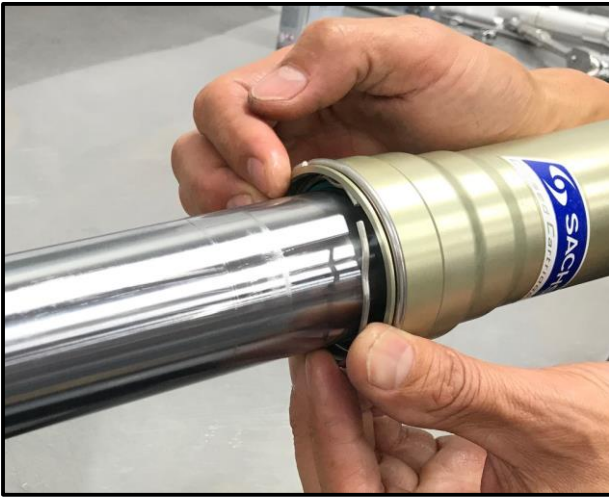

Insert the oil seal retaining circlip making sure it is fully seated into the groove.

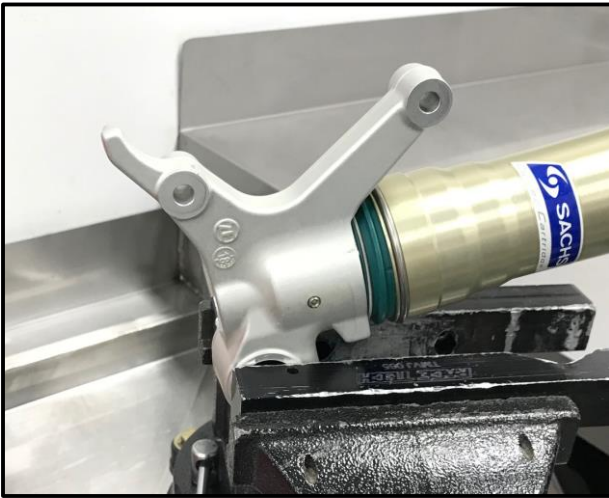

Push the outer fork leg against the axel lug until the dust seal is completely seated.

## 2012-2019' Cartridge Assembly

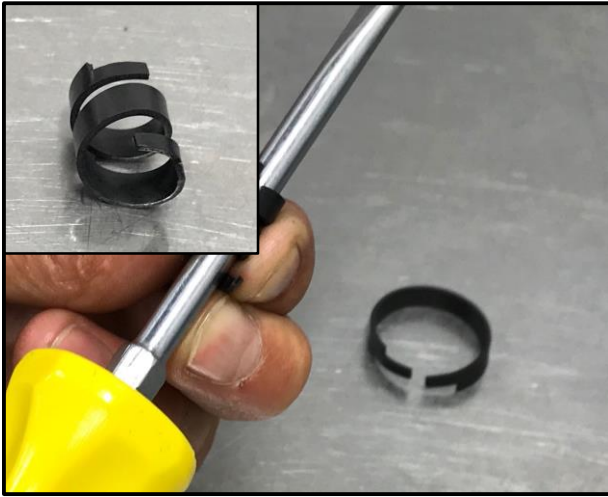

Wrap the Teflon Z band around a screwdriver.

Having it in a tight spiral will help keep it on the rebound piston during installation.



Install the Z band onto the rebound piston.



Insert the cartridge rod assembly into the cartridge cylinder.



Install the circlip onto the cartridge rod.



Apply grease to the O-ring groove on the rod then install the O-ring.

\* 2012-18'  
\* 2019

O-ring not applicable  
O-ring applicable



Apply grease to the threads inside the cartridge cylinder.

Apply grease to the threads and piston O-ring on the compression adjuster assembly.



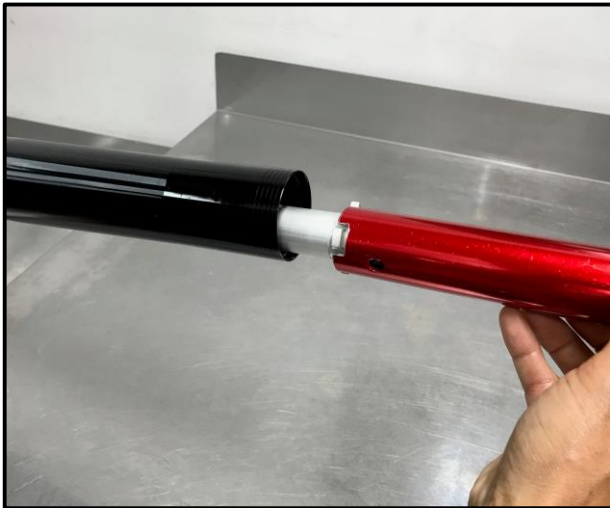

Insert the cartridge assembly into the fork external assembly.  
Slide the cartridge holding tool over the cartridge cylinder oil lock chamber and insert until fully bottomed.

**\*Cartridge Cylinder & Compression Assembly\***  
2012-18' NON specific to fork leg  
2019 Specific to each fork leg



Insert the greased compression assembly into the bottom of the fork leg.



Tighten the compression assembly and torque to 35Nm.



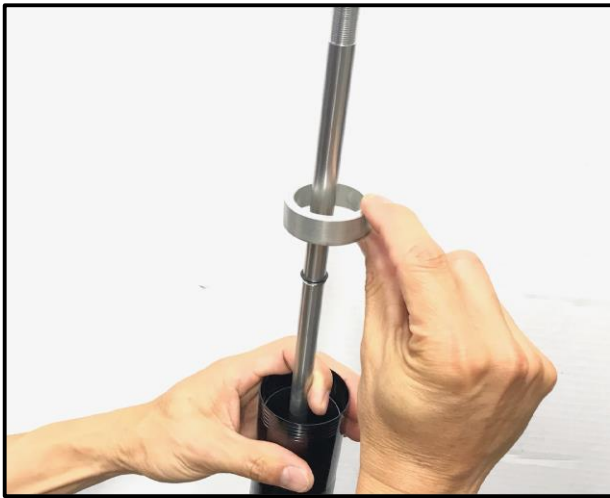

Install the spring seat collar over the cartridge rod, with the chamfered side facing downward.

\*2012-18' Spring seat collars are same in height, but will vary in material from year model.

\* 2019 Specific per fork leg  
Rebound Side = 9mm Tall  
Compression Side = 16mm Tall

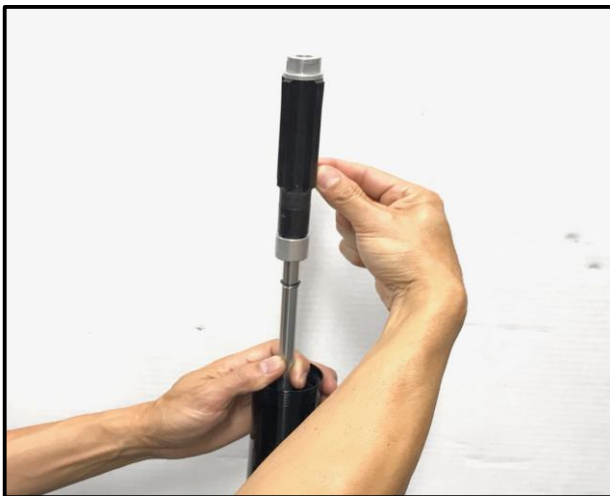

Thread the spring guide onto the cartridge rod, until completely bottomed.



Install the aluminum rebound push rod inside the cartridge rod.

\*2019 Non specific per fork leg

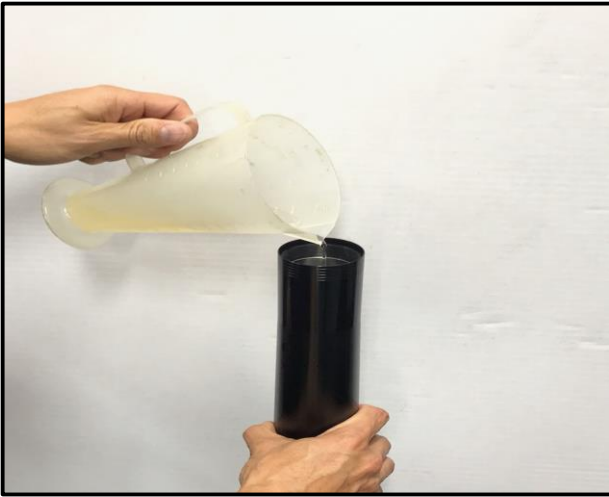

With the fork outer tube completely collapsed, fill the inner fork tube and cartridge assembly with 5 wt. fork fluid.

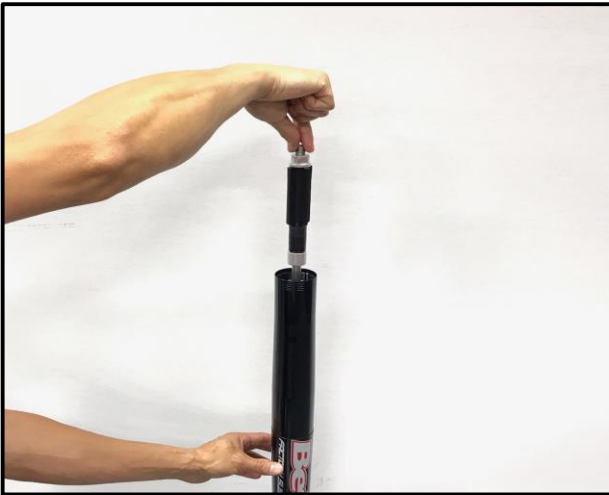

Cycle the cartridge rod up and down, until the cartridge rod has no apparent free spots and the fork fluid has no air bubbles rising to the surface.



Using a fork oil level gauge, set to the desired air space level inside the inner fork tube.

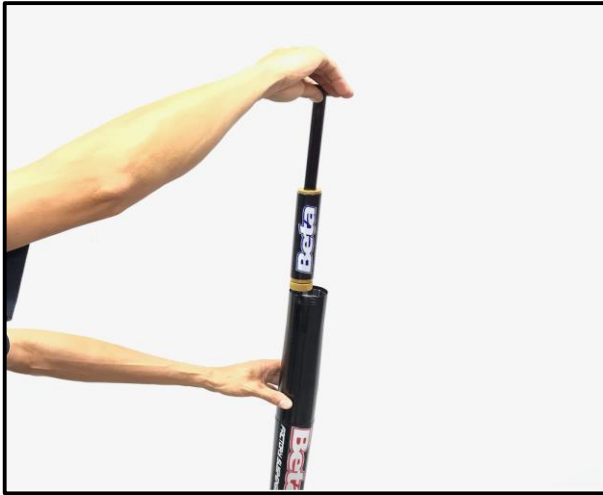

With the outer fork tube and cartridge rod bottomed, remove the excess fork fluid using the fork oil level tool.

***\*Recommended air space levels \****

Soft = 115mm

Comfort = 105mm

Sport = 95mm



Install fork spring.

**Suggestion:** If spring has an engraved rate on it, install the rate facing upwards to help determine the spring rate without having to remove the spring.



Pull downward on the fork spring and insert a 19mm low torque (thin) wrench onto the spring guide nut.

Next, install the fork cap and thread down completely. With the fork cap completely bottomed, you will notice available cartridge threads, thus indicating the fork cap is completely secure.



### 2019 Rebound Fork Cap (Brake side)

While holding the spring guide jam nut with the 19mm wrench, tighten the fork cap.

\*2012-18 Fork Cap/Rebound adjuster uses a 24mm hex and a 19mm spring guide jam nut on both forks.



### 2019 Compression / Pre-load Fork Cap (Non-Brake side)

Insert a 17mm low torque wrench above the spring guide nut, located on the lower part of the fork cap.

Holding the 19mm wrench, turn the 17mm wrench clockwise to tighten the fork cap against the spring guide nut.



Thread fork cap onto the fork outer tube and hand tighten. Never use thread lock!

# Fork Lowering Procedure

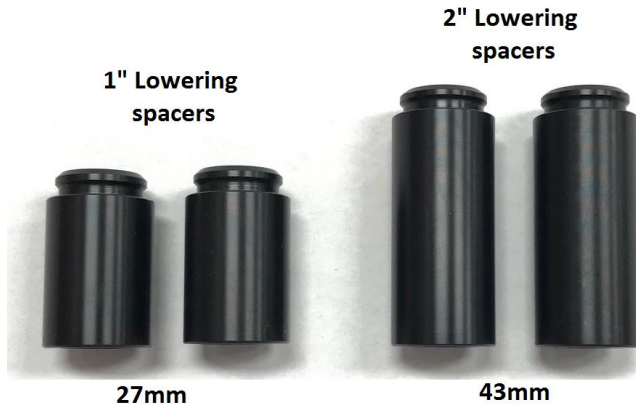

Lowering spacer placement on the cartridge rod.



1. Follow the fork disassembly procedures on pages 7-13.



2. Wrap the cartridge rod with paper and secure the rod with a cartridge rod holding clamp. Secure holding clamp with a soft jaw vise.

(Continued)



## Fork Lowering Procedure

continued

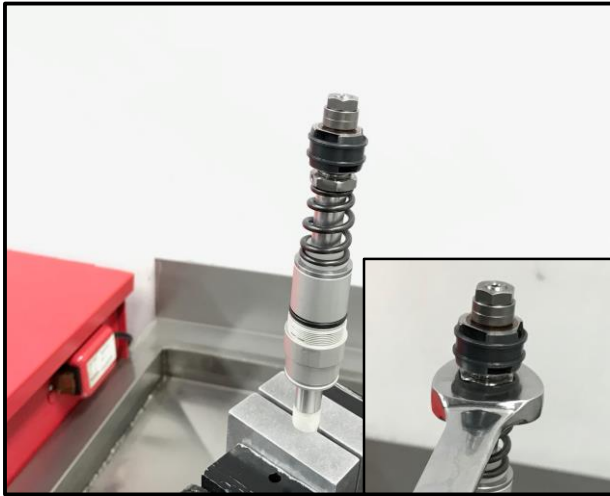

3. Use a 17mm wrench to loosen the rebound piston assembly.



4. Remove the rebound piston assembly from the cartridge rod.



5. Remove the top out spring from the cartridge rod, then remove the white spacer from the spring.

(Continued)



## Fork Lowering Procedure

continued



6. Use a vise to press the lowering spacer into the top out spring.

The side of the spacer with the groove goes towards inside the spring.



7. Install the lowering spacer with spring on the rod with the smaller end of the spring towards the top.

Apply a high strength thread locking agent to the threads on the rebound assembly.



8. Tighten the rebound assembly.

9. Proceed to pages 18-24 for reassembly procedures.