

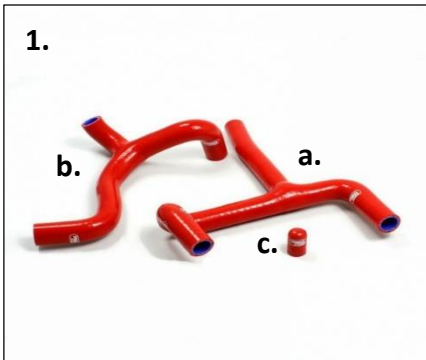

Samco Radiator Hose Install

Part# AB-21142

Fits: 2010-2015 4-stroke & 2018+ EFI 4-stroke



Installation Instructions:

The Samco Radiator Hose Kit includes: Y-Pipe (a), Crossover to water pump hose (b), bung cap (c).

Tools: 8mm socket, 5mm allen, flatblade screwdriver, measuring container, clean catch basin. Wash bike thoroughly, especially around the water pump & radiator hoses.

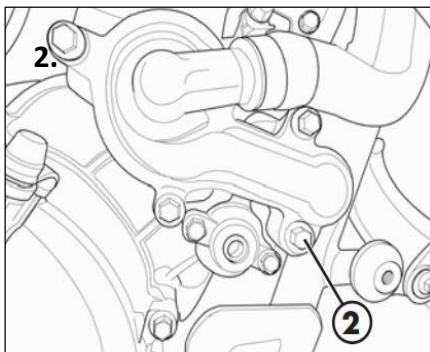

1. Put bike on a suitable workstand & place a coolant catch basin underneath bike.
2. Remove seat & gas tank along with both left & right radiator shrouds.
3. Loosen exhaust pipe mount springs at head, fasteners at front & rear of frame, then remove exhaust pipe, noting its distance from the stock coolant hoses.
4. Remove the radiator cap, & open the bleed screw on top of radiator.
5. Unscrew water pump housing screw (2) & fully drain the coolant, fig 2.
6. Remove all stock coolant hoses, taking note of their orientation & mounting.
7. Install hose clamps on Y-pipe (a), with bottom of y-pipe connected to the engine head, & both top tubes fully covering the radiator spigots, figs 3 & 4.
8. Install crossover hose (b) between lower left & right radiator bungs.
9. Install the water pump hose (c) to right radiator's front, lower radiator bung.
10. Cap the thermostat connector spigot at bottom of the left radiator with bung cap (c) & tighten hose clamp, as the Samco hoses eliminate the thermostat coupling.
11. Inspect hoses for proper positioning & connections, ensuring hoses are covering their bungs & are all angled correctly, then tighten all fasteners.
12. Ensure water pump to right radiator hose is angled closely to the engine & will have sufficient clearance from exhaust head pipe heat (test fit pipe if necessary).
13. Reinstall water pump housing drain screw & retorque to 10 nm.
14. With upper radiator bleed screw cracked open to let air escape, refill cooling system until coolant level appears at bottom of filler cap mount.
15. Start the engine, warm it to operating temperature & top off the system with specified amount of coolant, being sure to close the bleed screw afterwards.
16. Reinstall the radiator cap, exhaust pipe, gas tank, radiator shrouds, & seat.