

**CATALOGO PARTI DI RICAMBIO**  
**CATALOGUE OF SPARE PARTS**  
**CATALOGUE PIECES DE RECHANGE**  
**ERSATZTEILKATALOG**  
**CATALOGO DE PIEZAS DE REPUESTO**



Le presenti immagini e i contenuti sono di esclusiva titolarità di Betamotor S.p.A., che si riserva tutti i relativi diritti. Non è consentita alcuna riproduzione, modifica, elaborazione, divulgazione, comunicazione, utilizzazione economica in ogni forma e modo, originale o derivato, che non sia espressamente consentita per iscritto da Betamotor S.p.A. Qualsiasi violazione sarà perseguita da parte di Betamotor S.p.A. in tutte le opportune sedi civili e penali.

*The images and content herein are the exclusive property of Betamotor SpA, which reserves all rights thereto. Any reproduction, modification, editing, dissemination, communication, exploitation in any form and way, original or derived, is strictly forbidden if not expressly approved in writing by Betamotor SpA. Any violation will be actively pursued in all relevant civil and criminal forums by Betamotor SpA.*

Toutes les images et le contenu qui se trouvent dans ce document sont la propriété exclusive de Betamotor SpA, qui se réserve tous les droits. Toute reproduction, modification, édition, diffusion, communication, ou exploitation sous quelque forme et de quelque manière, originale ou dérivée, est strictement interdite sans l'autorisation écrite expresse de Betamotor SpA. Toute violation sera poursuivie par Betamotor SpA dans toutes les cours civiles et pénales compétentes.

*Die vorliegenden Abbildungen und Inhalte sind Alleinbesitz von Betamotor S.p.A., die sich alle diesbezüglichen Rechte vorbehält. Ohne die ausdrückliche schriftliche Genehmigung von Betamotor S.p.A. ist keine Art von Reproduktion, Änderung, Verarbeitung, Verbreitung, Mitteilung an Dritte, wirtschaftliche Nutzung in jeder Form und auf jede Art, weder im Original noch davon abgeleitet, erlaubt. Jede Zuwiderhandlung wird von Betamotor S.p.A. über alle zuständigen zivil- und strafrechtlichen Gerichtsstellen verfolgt.*

Las imágenes y el contenido de este documento son propiedad exclusiva de Betamotor SpA, que se reserva todos los derechos. Cualquier reproducción, modificación, procesamiento, difusión, comunicación, explotación en cualquier forma y manera, originaria o derivada, están estrictamente prohibidas si no están aprobadas expresamente por escrito por Betamotor SpA. Cualquier violación será perseguida por Betamotor SpA en todas las sedes competentes civiles y penales.

TAV.01 Basamento - Crankcase - Carter - Kurbelgehäuse - Carter

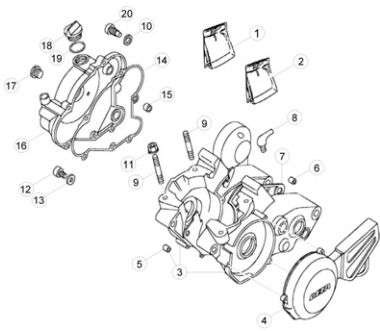

Pag. 6

TAV.02 Albero motore-Pistone - Crankshaft-Piston - Vilebrequin-Piston - Kurbelwelle-Kolben - Cigüeñal-Pistón

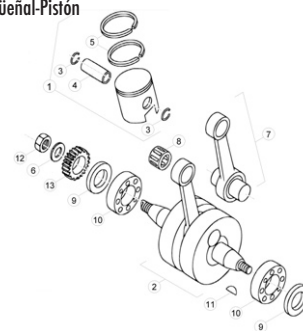

Pag. 7

TAV.03 Frizione - Clutch - Embrayage - Kupplung - Embrague

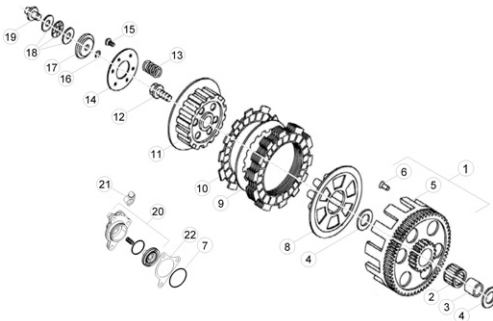

Pag. 8

TAV.04 Ingranaggi cambio - Gear group - Engrenages changement de vitesses - Schaltgetriebe - Engranaje del cambio

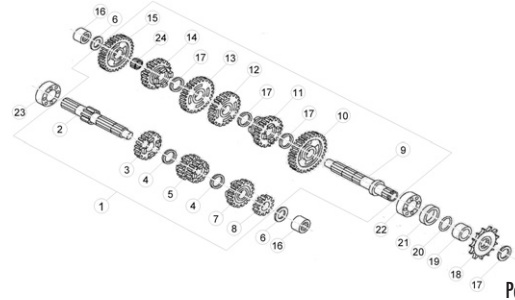

Pag. 9

TAV.05 Comando cambio - Gear shift control - Commande changement de vitesse - Chaltung - Mando cambio

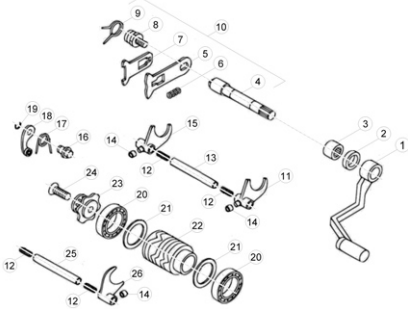

Pag. 10

TAV.06 Avviamento a pedale - Kickstarter - Démarrage à pedal - Pedalstart - Arranque a pedal

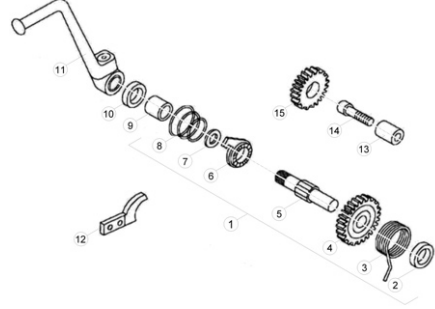

Pag. 11

TAV.09 Pompa acqua - Water pump - Pompe d'eau - Wasserpumpe - Bomba de agua

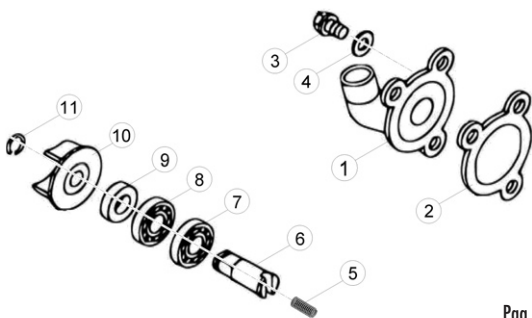

Pag. 12

TAV.10 Gruppo accensione elettronica - Electronic ignition assy. - Groupe allumage électronique - Elektronischezündung gruppe - Grupo encendido electrónico

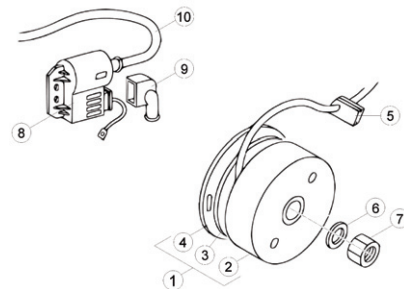

Pag. 13

TAV.11 Testa-Cilindro - Cylinder head-Cylinder - Culasse-Cylindre - Zylinderkopf-Zylinder - Culata-Cilindro

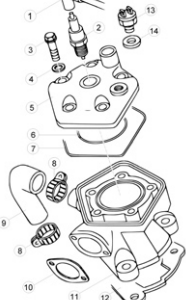

Pag. 14

TAV.12 Carburatore e raccordo d'ammissione - Carburettor and and induction pipe - Carburateur et raccord d'admission - Vergaser und Ansaugstutzen - Carburador y racor de admision

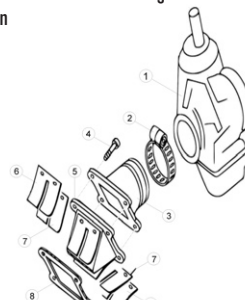

Pag. 15

TAV.31 Telaio - Frame - Chassis - Rahmen - Chasis

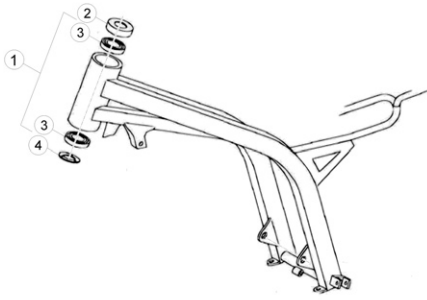

Pag. 16

TAV.32 Accessori telaio - Frame accessories - Accessoires chassis - Rahmenzubehören - Accesorios Chasis

**JUNIOR**

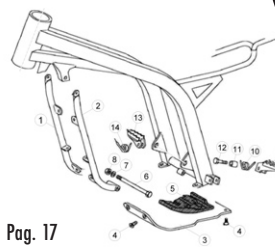

Pag. 17

**SENIOR**

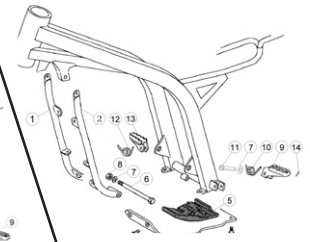

Pag. 18

TAV.33 Forcellone posteriore - Rear fork - Fourche arriere - Hinterradschwinge - Horquilla posterior

**JUNIOR**

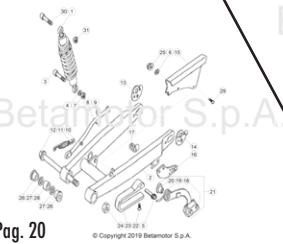

Pag. 20

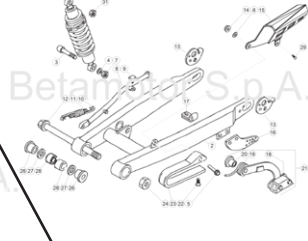

**SENIOR**

Pag. 22

TAV.34 Forcella anteriore - Front fork - Fourche AV. - Vorderradgabel - Horquilla delantera

**SENIOR**

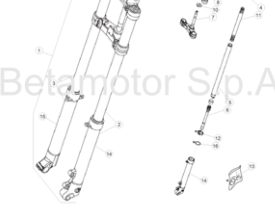

Pag. 24

**JUNIOR**

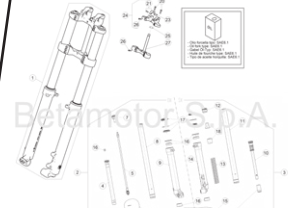

Pag. 26

TAV.35 Comandi-Manubrio - Controls-Handlebars - Commandes-Guidon - Bedienungselemente-Lenker - Mandos-Manillar

**SENIOR**

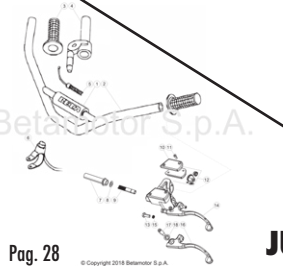

Pag. 28

**JUNIOR**

Pag. 29

TAV.36 Impianto freni idraulici - Hydraulic brakes system - Installation des freins hydrauliques - Hidraulischebremse anlage - Instalación freno hidráulico

**JUNIOR**

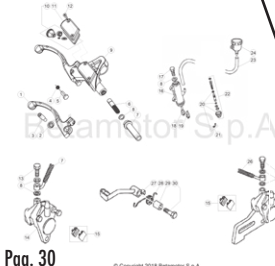

Pag. 30

**SENIOR**

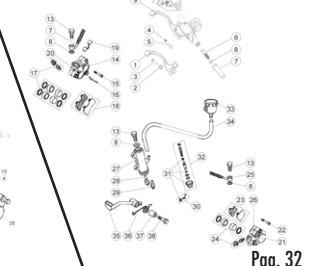

Pag. 32

TAV.37 Gruppo scarico - Exhaust system - Echappement - Auspuffanlage - Grupo escape

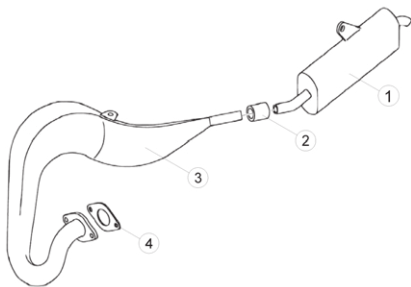

Pag. 34

TAV.38 Scatola filtro - Filter box - Boîtier du filtre - Sicherungskasten - Caja del filtro

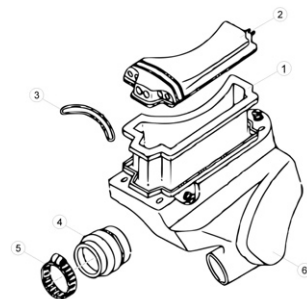

Pag. 35

TAV.39 Impianto di raffreddamento - Installation de refroidissement - Installation de refroidissement - Kühlsystem - Instalación de enfriamiento

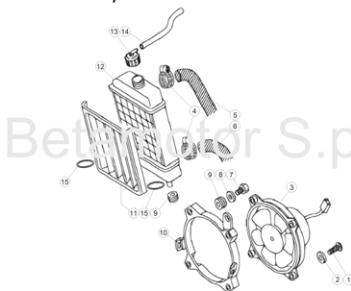

Pag. 36

TAV.40 Impianto elettrico - Electrical equipment - Installation électrique - Elektrische anlage - Instalación eléctrica

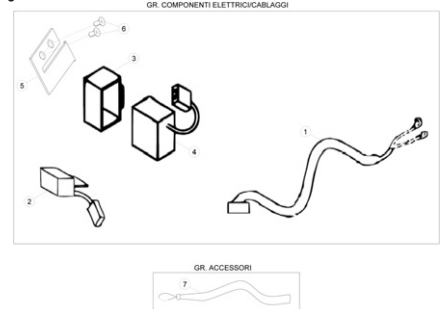

Pag. 37

TAV.41 Ruota anteriore - Front wheel - Roue AV. - Vorderrad - Rueda delantera

**JUNIOR**

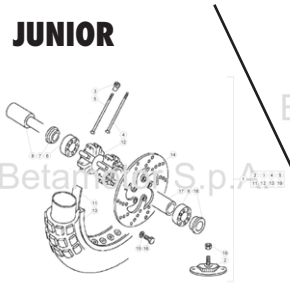

Pag. 38

© Copyright 2016 Betamotor S.p.A.

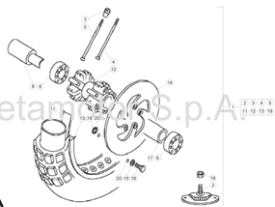

© Copyright 2016 Betamotor S.p.A.

**SENIOR**

Pag. 39

TAV.42 Ruota posteriore - Rear wheel - Roue AR. - Hinterrad - Rueda trasera

**JUNIOR**

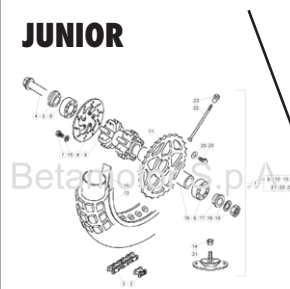

Pag. 40

© Copyright 2016 Betamotor S.p.A.

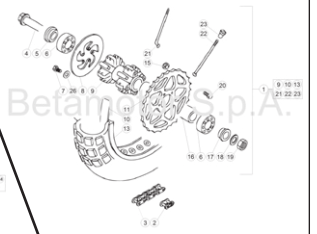

© Copyright 2017 Betamotor S.p.A.

**SENIOR**

Pag. 42

TAV.43 Carenature-Serbatoio-Sella - Fairings-Tank-Saddle - Carenages-Reservoir-Selle - Verkleidungen-Tank-Sattel - Carenados-Deposito-Sillin

**SENIOR**

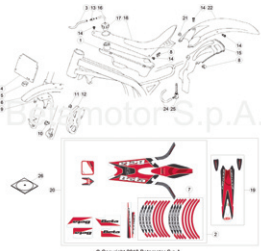

Pag. 44

**JUNIOR**

© Copyright 2018 Betamotor S.p.A.

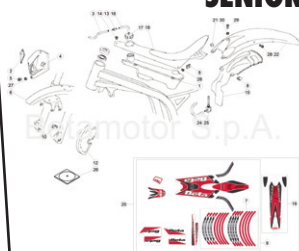

© Copyright 2018 Betamotor S.p.A.

Pag. 46



# Tav.01

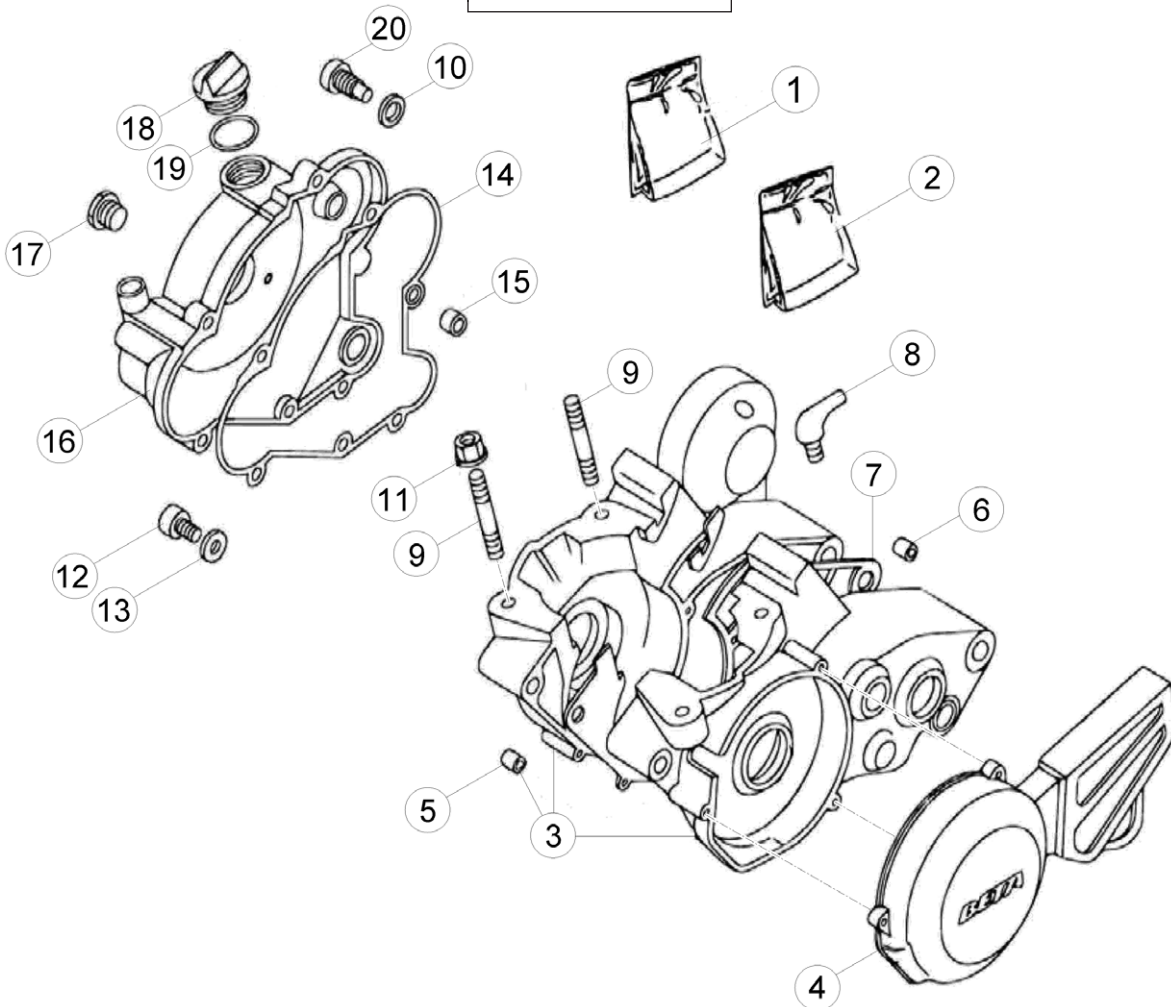

Pos Loc Pos Ps Pos	Numero Number Numéro Número Nummer	Q.tà Q.ty Q.té M.ge C.ad	Nota Note Note Nota Anm.	Descrizione	Description	Désignation	Beschreibung	Descripción
1	28.06887.800	1		Serie anelli paraolio	oil seal rings set	Jeu joints spi	Öldichtungsringensatz	Serie anillos guardagotas
2	28.08067.800	1		Serie guarnizioni	Set of gaskets	Jeu de joints	Dichtungssatz	Juego de juntas
3	12.06232.800	1		Carter completo	Crankcase assy	Carter comp.	Kurbelwellengehäuse komp.	Cárter comp.
4	12.70084.057	1		Coperchio volano	Flywheel cover	Carter volant	Schwungraddeckel	Tapa volante
5	16.41510.000	1		Grano di riferimento	Dowel	Repère	Passtift	Centraje
6	16.41530.000	1		Grano di riferimento	Dowel	Repère	Passtift	Centraje
7	16.55030.000	1		Guarnizione carter	Crankcase gasket	Joint carter	Dichtung Kurbelwellengehäuse	Junta cárter
8	27.23470.000	1		Raccordo per sfiato	Breather pipe	Raccord pour vidange	Entlüftungsrohranschluß	Racor para ventilación
9	25.98050.000	4		Prigioniero 8x41	Stud 8x41	Goujon 8x41	Stiftschraube 8x41	Espárrago 8x41
10	16.49100.000	1		Guarnizione in rame 8x12x0,5	Copper gasket 8x12x0,5	Joint en cuivre 8x12x0,5	Kupferdichtung 8x12x0,5	Junta de cobre 8x12x0,5
11	13.17121.000	4		Dado speciale M8	Special nut M8	Ecrou spéciale M8	Spezialmutter M8	Tuerca especial M8
12	11.58020.000	1		Bullone speciale	Special bolt	Boulon spéciale	Spezialschraube	Tornillo especial
13	16.50511.000	1		Guarnizione 10x15x2 rame	Packing 10x15x2 rame	Joint 10x15x2 rame	Dichtung 10x15x2 rame	Junta 10x15x2 rame
14	16.71520.000	1		Guarnizione coperchio frizione	Clutch cover gasket	Joint couvercle embrayage	Dichtung Kupplungsabdeckung	Junta tapa embrague
15	16.37010.000	1		Grano di riferimento 9x15	Dowel 9x15	Repère 9x15	Passtift 9x15	Centraje 9x15
16	004.01.010.00.33	1		Coperchio frizione	Clutch cover	Couvercle d'embrayage	Kupplungsdeckel	Tapa embrague
17	29.10030.000	1		Tappo indicatore olio	Oil inspection plug	Bouchon contrôle huile	Ölstopfen	Tapón inspección aceite
18	29.09600.000	1		Tappo alimentazione olio	Oil plug	Bouchon approv. huile	Öleinfüllstopfen	Tapón aceite alimentación
19	10.66340.000	1		Anello OR 16x3	O-Ring 16x3	Bague d'étanchéité 16x3	O-Ring 16x3	Anillo OR 16x3
20	31.88500.000	1		Vite richiamo molla	Return spring screw	Vis rappel ressort	Rückholschraube Feder	Tornillo retroceso muelle

# Tav.02

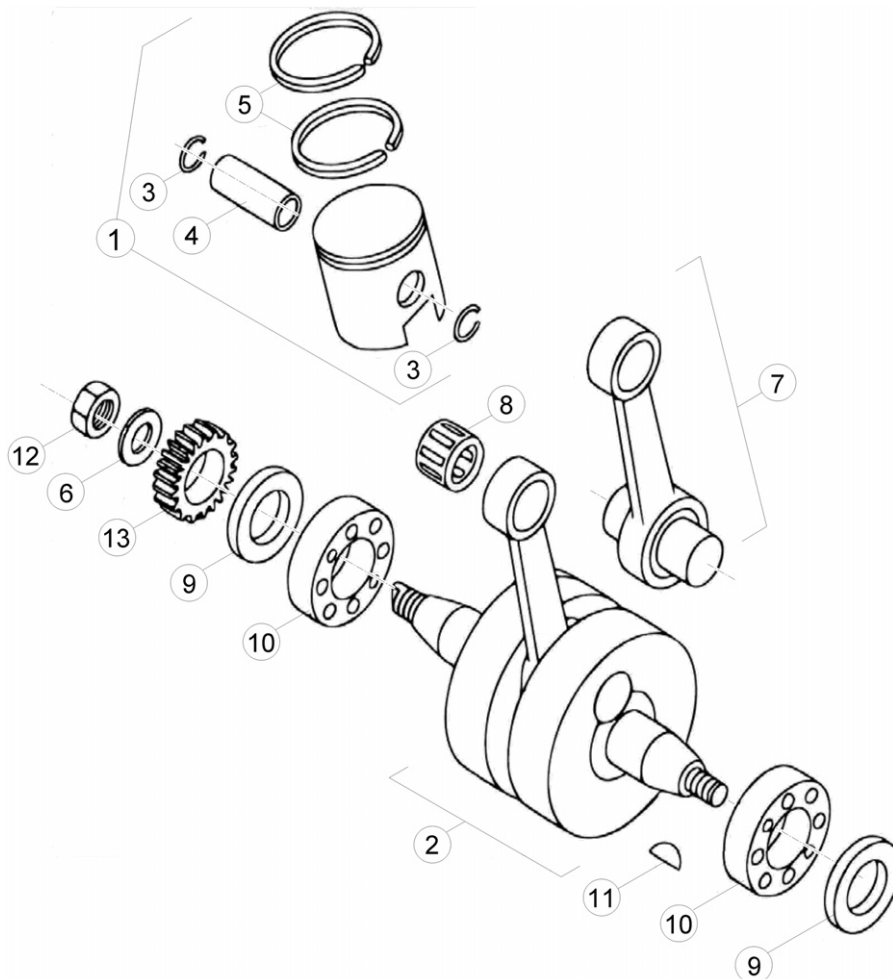

Pos Loc Pos Ps Pos	Numero Number Numéro Número Nummer	Q.tà Q.ty Q.té M.ge C.ad	Nota Note Note Nota Anm.	Descrizione	Description	Désignation	Beschreibung	Descripcìon
1	25.80270.800	1		Pistone completo	Piston set	Piston compl.	Kolben, kompl.	Pistón, compl.
2	10.00682.000	1		Albero motore completo	Crankshaft, assy.	Arbre moteur complet	kurbelwelle, komplett	Cigüeñal completo
3	10.42010.000	2		Anello	Ring	Circlips	Ring	Anillo
4	28.93620.000	1		Spinotto	Pin	Axe	Zapfen	Eje
5	28.60180.000	2		Segmento	Compression ring	Segment	Kompressions-Kolbenring	Aro de compresión
6	27.61550.000	1		Rondella spess. C72	Washer 15x25 C72	Rondelle epaisseur 15x25 C72	Scheibe 15x25 C72	Arandela 15x25 C72
7	11.03716.800	1		Biella completa	Conn.-rod, assy	Bielle compl.	Pleuel, kompl.	Biela compl.
8	16.11500.000	1		Gabbia a rulli	Roller cage	Cage a roul.	Rollenkäfig	Jaula de rod.
9	10.64111.000	2		Anello paraolio	Oil seal	Joint d'étanchéité	Ölschutzring	Retén de aceite
10	12.99022.000	2		Cuscinetto 20x52x15	Bearing 20x52x15	Roulement 20x52x15	Lager 20x52x15	Cojinete 20x52x15
11	12.46000.000	1		Chiavetta	Key	Clavette	Keil	Chaveta
12	13.28951.000	1		Dado speciale	Special nut	Ecrou spéciale	Spezialmutter	Tuerca especial
13	29.07303.800	1		Trasmissione primaria compl.	Primary drive	Transmission principale	Hauptantrieb	Transmisión primaria

# Tav.03

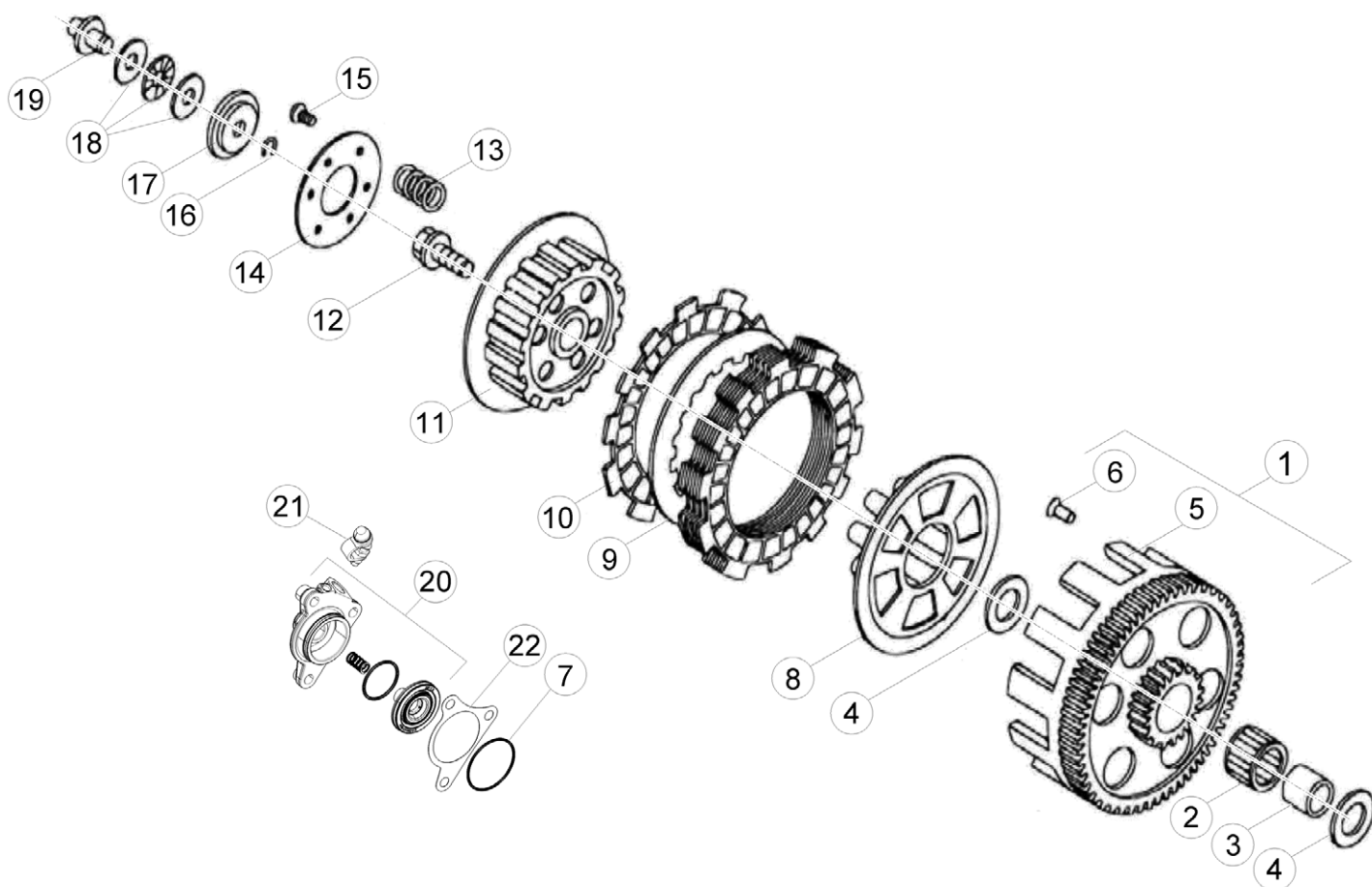

Pos Loc Pos Ps Pos	Numero Number Numéro Número Nummer	Q.tà Q.ty Q.té M.ge C.ad	Nota Note Note Nota Anm.	Descrizione	Description	Désignation	Beschreibung	Descripció
1	29.07303.800	1		Trasmissione primaria compl.	Primary drive	Transmission principale	Hauptantrieb	Transmisión primaria
2	16.17280.000	1		Gabbia 21.25.17	Cage 21.25.17	Cage 21.25.17	Lagerkäfig 21.25.17	Jaula 21.25.17
3	11.27120.000	1		Boccola 17.21.17,2	Bush 17.21.17,2	Moyeu 17.21.17,2	Büchse 17.21.17,2	Buje 17.21.17,2
4	27.71100.000	2		Rondella 17.30.1,5	Washer 17.30.1,5	Rondelle 17.30.1,5	U.Scheibe 17.30.1,5	Arandela 17.30.1,5
5	12.20770.000	1		Campana frizione	Clutch case	Cloche d'embrayage	Kupplungsglocke	Campana de embr.
6	27.31640.000	6		Ribattino 5.9	Rivet 5.9	Rivet 5.9	Niet 5.9	Remache 5.9
7	10.66840.000	1		Anello OR 33x1,5	O-Ring 33x1,5	Bague d'étanchéité 33x1,5	O-Ring 33x1,5	Anillo OR 33x1,5
8	12.29593.000	1		Cappello frizione	Clutch pressure plate	Capuchon d'embrayage	Abdeckkappe kupplung	Tapa del embrague
9	13.38130.000	5		Disco in acciaio	Steel plate	Disque lisse	Stahlscheibe	Disco
10	004.03.010.00.00	6		Disco sugherite	"Sugherite" clutch disc	Disque en "sugherite"	Scheibe "Sugherite"	Disco "sugherite"
11	29.09613.000	1		Tamburino frizione	Clutch drum	Noix d'embrayage	Kupplungstrommel	Tambor embrague
12	11.59150.000	1		Bullone 10.20	Bolt 10.20	Boulon 10.20	Bolzen 10.20	Tornillo 10.20
13	22.65093.000	6		Molla frizione	Clutch spring	Ressort embr.	Kupplg.feder	Muelle embr.
14	13.42050.000	1		Disco porta molle	Spring carrier plate	Disque porte-ressorts	Federträgerscheibe	Disco porta muelles
15	31.34400.000	6		Vite brugola tspsc M6x20	Socket head screw M6x20	Vis allen tspsc M6x20	Inbusschraube tspsc M6x20	Tornillo de cabeza hex. tspsc M6x20
16	28.22610.000	1		Seeger 6e	Circlip 6e	Circlip 6e	Seeger 6e	Seeger 6e
17	032.03.089.00.00	1		Scodellino	Stop washer	Rondelle d'ar	Federaufnahme	Platillo
18	16.11250.000	1		Gabbia reggispinta 6.19.2 c/ralle	Thrust bearing cage 6.19.2 c/ralle	Butée à aiguilles 6.19.2 c/ralle	Andruckkäfig 6.19.2 c/ralle	Jaula cojinete de empuje 6.19.2 c/ralle
19	25.52991.000	1		Perno	Pin	Pivot	Zapfen	Perno
20	004.03.080.80.00	1		Attuatore frizione	Clutch actuator	Actuateur embrayage	Kupplung-Reglereinheit	Actuador embrague
21	28.91050.800	1		Sfiato aria	Bleed nipple	Purge d'air	Entlüftungsnippel	Respiradero
22	006.03.085.00.00	1		Guarnizione frizione	Clutch lining	Garniture embrayage	Kupplungsbelag	Forro de embrague



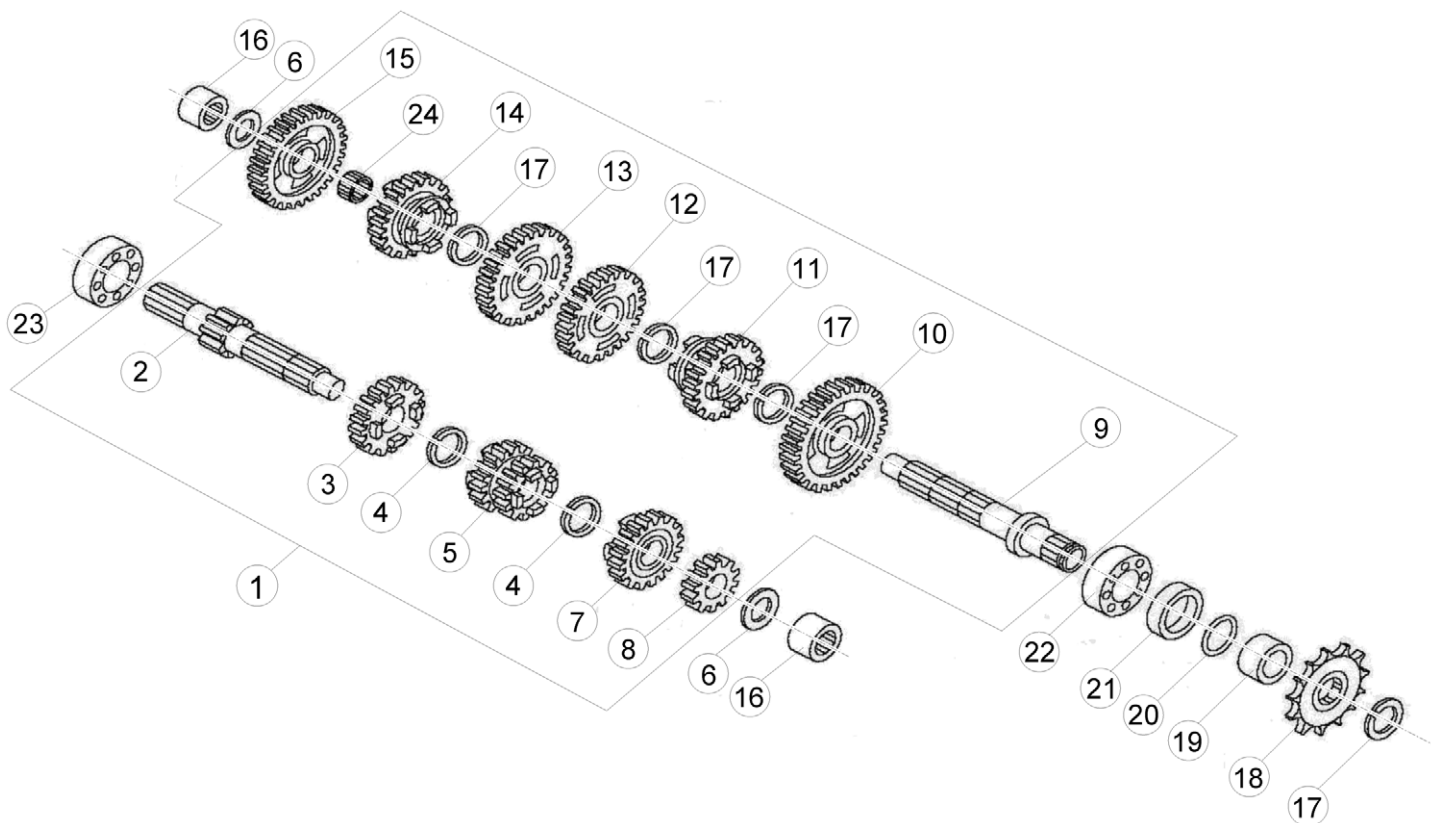

Pos Loc Pos Ps Pos	Numero Number Numéro Número Nummer	Q.tà Q.ty Q.té M.ge C.ad	Nota Note Note Nota Anm.	Descrizione	Description	Désignation	Beschreibung	Descrìpziòn
1	12.00686.800	1		Cambio completo	Transmission, assy	Boîte de vitesses	Getriebe komplett	Cambio completo
2	10.23520.800	1		Albero primario	Mainshaft	Arbre primaire	Hauptwelle	Arbol primario
3	18.38412.800	1		Ingranaggio 5° A.P.	Main shaft 5th gear	Engrenage 5ème vitesse A.P.	Zahn. f. 5. Geschw. Antriebsw.	Engranaje 5° velocidad Eje P.
4	28.24950.000	2		Seeger 17 sw	Circlip 17 sw	Circlip 17 sw	Seeger 17 sw	Seeger 17 sw
5	18.37652.800	1		Ingranaggio 3°-4° A.P.	Main shaft 3rd- 4th gear	Engrenage 3ème- 4ème vitesse A.P.	Zahn. f. 3.- 4. Geschw. Antriebsw.	Engranaje 3°- 4° velocidad Eje P.
6	27.60500.000	2		Rondella spess. c72 12.25.1	Washer 15x25 c72 12.25.1	Rondelle epaisseur 15x25 c72 12.25.1	Scheibe 15x25 c72 12.25.1	Arandela 15x25 c72 12.25.1
7	18.38742.800	1		Ingranaggio 6° A.P.	Main shaft 6th gear	Engrenage 6ème vitesse A.P.	Zahn. f. 6. Geschw. Antriebsw.	Engranaje 6° velocidad Eje P.
8	18.34110.800	1		Ingranaggio 2° A.P.	Main shaft 2nd gear	Engrenage 2ème vitesse A.P.	Zahn. f. 2. Geschw. Antriebsw.	Engranaje 2° velocidad Eje P.
9	10.28051.800	1		Albero secondario	Counter shaft	Arbre secondaire	Nebentriebewelle	Eje secundario
10	18.52030.800	1		Ingranaggio 2° A.S.	Secondary shaft 2nd gear	Engrenage 2ème vitesse A.S.	Zah. f. 2. Geschw. Vorgelegew.	Engranaje 2° velocidad Eje S.
11	18.67142.800	1		Ingranaggio 6° A.S.	Secondary shaft 6th gear	Engrenage 6ème vitesse A.S.	Zahn. f. 6. Geschw. Vorgelegew.	Engranaje 6° velocidad Eje S.
12	18.61500.800	1		Ingranaggio 3° A.S.	Secondary shaft 3rd gear	Engrenage 3ème vitesse A.S.	Zah. f. 3. Geschw. Vorgelegew.	Engranaje 3° velocidad Eje S.
13	18.64100.800	1		Ingranaggio 4° A.S.	Secondary shaft 4th gear	Engrenage 4ème vitesse A.S.	Zah. f. 4. Geschw. Vorgelegew.	Engranaje 4° velocidad Eje S.
14	18.66442.800	1		Ingranaggio 5° A.S.	Secondary shaft 5th gear	Engrenage 5ème vitesse A.S.	Zah. f. 5. Geschw. Vorgelegew.	Engranaje 5° velocidad Eje S.
15	18.43023.800	1		Ingranaggio 1° A.S.	Gear 1st speed	Engrenage 1ère	Zahnrad 1. Gang	Engranaje 1° velocidad
16	11.22250.000	2		Boccola a rulli nk 12.19.12	Roller bearing nk 12.19.12	Douille à roulements nk 12.19.12	Rollenbuchse nk 12.19.12	Caja de grasa de rodillos nk 12.19.12
17	28.25410.000	4		Seeger as 20e	Circlip as 20e	Circlip as 20e	Seeger as 20e	Seeger as 20e
18	25.61050.000	1		Pignone catena z.11	Chain sprocket z.11	Pignon chaîne z.11	Kettenritzel z.11	Piñón cadena z.11
19	13.55250.000	1		Distanziale pignone	Sprocket spacer	Entretoise pignon	Distanzstück Ritzel	Distancidor piñón
20	10.66350.000	1		Anello or 18,77,22,33,1,78	O-Ring 18,77,22,33,1,78	Bague d'étanchéité 18,77,22,33,1,78	O-Ring 18,77,22,33,1,78	Anillo OR 18,77,22,33,1,78
21	10.64700.000	1		Anello paraolio 26.35.7	Oil seal 26.35.7	Joint d'étanchéité 26.35.7	Ölschutzring 26.35.7	Retén de aceite 26.35.7
22	12.98000.000	1		Cuscinetto 20.42.12	Bearing 20.42.12	Roulement 20.42.12	Lager 20.42.12	Cojinete 20.42.12
23	12.95500.000	1		Cuscinetto 17.40.9	Bearing 17.40.9	Roulement 17.40.9	Lager 17.40.9	Cojinete 17.40.9
24	16.12650.000	1		Gabbia 14.18.8	Cage 14.18.8	Cage 14.18.8	Lagerkäfig 14.18.8	Jaula 14.18.8

# Tav.05

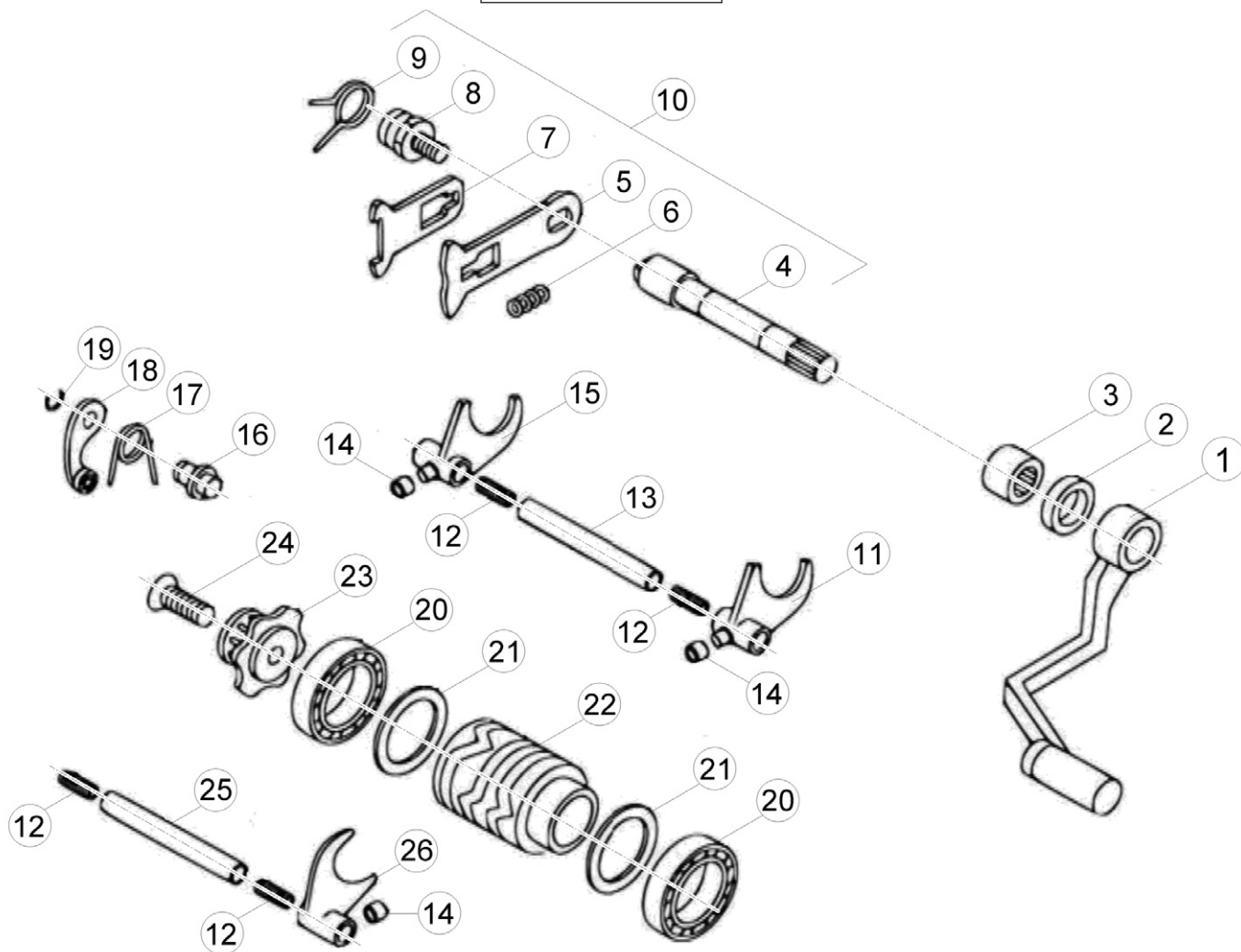

Pos Loc Pos Ps Pos	Numero Number Numéro Número Nummer	Q.tà Q.ty Q.té M.ge C.ad	Nota Note Note Nota Anm.	Descrizione	Description	Désignation	Beschreibung	Descripcìon
1	004.05.000.00.00	1		Leva com. cambio	Gearshift lever	Levier de vitesse	Schalthebel	Palanca mando cambio
2	10.47500.000	1		Anello paraolio 12.20.5	Oil seal 12.20.5	Joint d'étanchéité 12.20.5	Ölschutzring 12.20.5	Retèn de aceite 12.20.5
3	11.22200.000	1		Boccola a rullini 12x18x12	Roller cage 12x18x12	Cage Aiguille 12x18x12	Rollenkäfig 12x18x12	Jaula rodillos 12x18x12
4	10.12010.000	1		Albero comando cambio	Gearshift shaft	Arbre de vitesse	Schaltwelle	Eje mando cambio
5	31.20975.800	1		Ventaglio mobile con perno cr 85	Movable pawl with pin cr 85	Eventail mobile avec pivot cr 85	Schaltautomat mit Bolzen cr 85	Abanico móvil con perno cr 85
6	22.68010.000	1		Molla ventaglio	Pawl spring	R ressort éventail	Schaltfeder	Muelle del abanico
7	31.20980.800	1		Ventaglio mobile con perno	Movable pawl with pin	Eventail mobile avec pivot	Schaltautomat mit Bolzen	Abanico móvil con perno
8	25.54410.000	1		Perno	Pin	Pivot	Zapfen	Perno
9	22.72030.000	1		Molla ritorno comando cambio	Gearchange return spring	R ressort de retour comm. ch.ge vit.	Rückstellfeder schaltung	Muelle de retorno cambio
10	10.12010.800	1		Albero comando cambio	Gearshift shaft	Arbre de vitesse	Schaltwelle	Eje mando cambio
11	15.64012.000	1		Forchetta 1-4	Fork 1-4	Fourchette 1-4	Schaltgabel 1-4	Horquilla 1-4
12	22.65015.000	4		Molla	Spring	R ressort	Feder	Muelle
13	25.51021.000	1		Perno forchetta 10.80	Spindle, fork 10.80	Axe de fourche 10.80	Schaltgabelstift 10.80	Perno de la horquilla 10.80
14	11.29035.000	3		Boccola	Bush	Moyeu	Büchse	Buje
15	15.64011.000	1		Forchetta 2-3	Fork 2-3	Fourchette 2-3	Schaltgabel 2-3	Horquilla 2-3
16	25.54430.000	1		Perno fiss. Leva	Lever sec. Pin	Pivot fix. Levier	Befestigungstift Hebel	Perno fij. Palanca
17	22.39581.000	1		Molla arresto marce	Gear stop spring	R ressort arrêt vit.	Gangstoppfeder	Muelle arresto vel.
18	21.17150.000	1		Leva arresto marce completa	Gear stop lever	Levier arrêt vit.	Gangstopphebel	Palanca arresto vel.
19	28.22700.000	1		Seeger 10E	Circlip 10E	Circlip 10E	Seeger 10E	Seeger 10E
20	12.99405.000	2		Cuscinetto 25x37x7	Bearing 25x37x7	Roulement 25x37x7	Lager 25x37x7	Cojinete 25x37x7
21	27.73695.000	2		Rondella spess. 25.32	Washer 15x25 25.32	Rondelle epaisseur 15x25 25.32	Scheibe 15x25 25.32	Arandela 15x25 25.32
22	12.19113.000	1		Camma	Cam	Came	Nocke	Excéntrica
23	12.19122.000	1		Camma arresto marce	Gear Stopper Cam	Came Butée Vitesses	Gangsperrnocken	Leva Parada Marchas
24	31.30510.000	1		Vite 6x30	Screw 6x30	Vis 6x30	Schraube 6x30	Tornillo 6x30
25	25.51011.000	1		Perno guida forchetta 10.67,5	Selector pin 10.67,5	Pivot guide fourche 10.67,5	Schaltgabel Pin 10.67,5	Eje horquilla 10.67,5
26	15.64031.000	1		Forchetta 5-6	Fork 5-6	Fourchette 5-6	Schaltgabel 5-6	Horquilla 5-6

# Tav.06

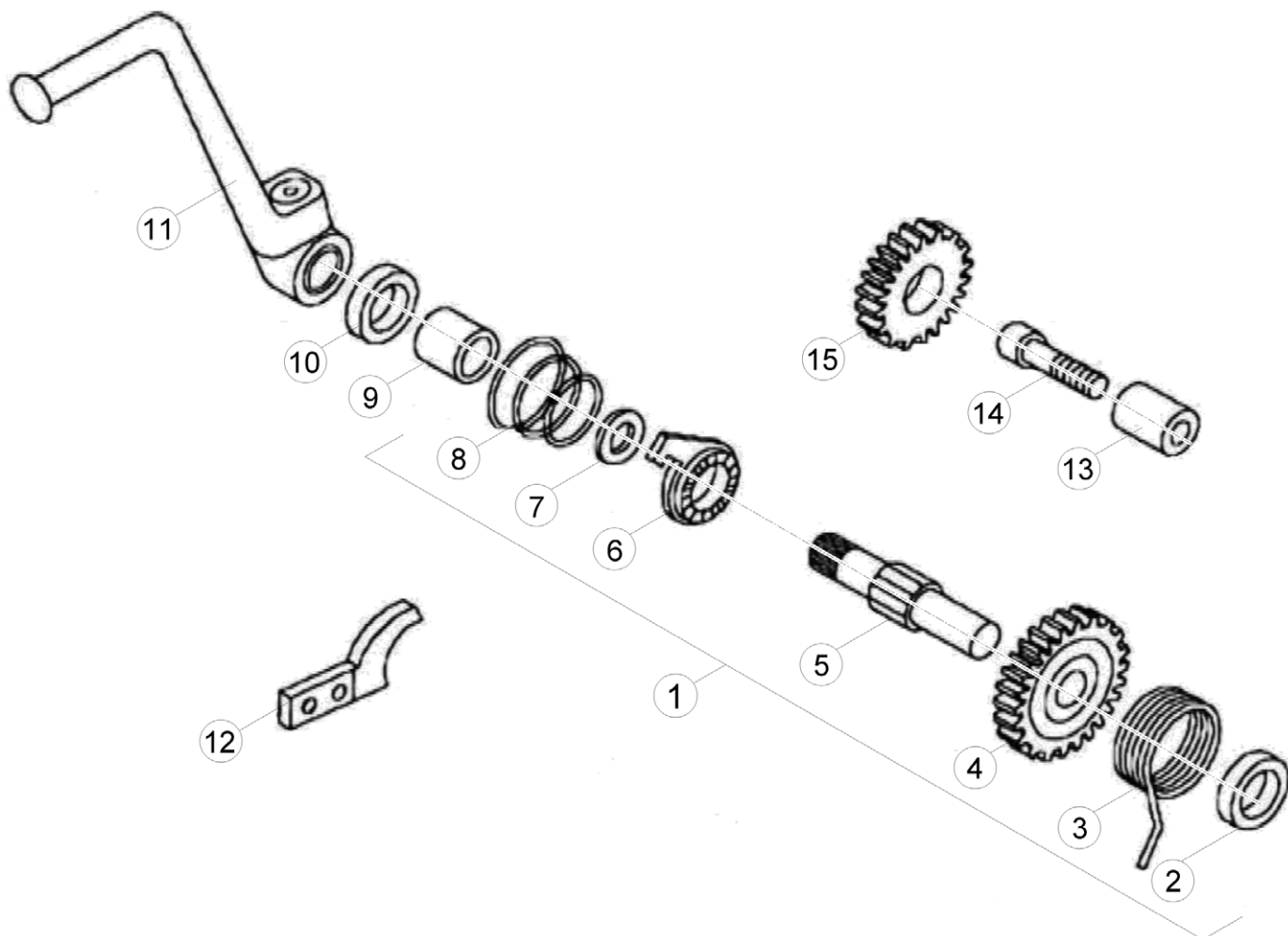

Pos Loc Pos Ps Pos	Numero Number Número Nummer	Q.tà Q.ty Q.té M.ge C.ad	Nota Note Note Nota Anm.	Descrizione	Description	Désignation	Beschreibung	Descripcìon
1	22.05070.800	1		Messa in moto completa	Kickstart, assy.	Système de demarrage complet	Starter komplett	Arranque completo
2	13.48080.000	1		Distanziale messa in moto	Spacer, kickstart	Entretoise démarrage	Distanzstück starter	Distanciador del arranque
3	22.78250.000	1		Molla ritorno leva m.m.	Kickstart lever return spring	R ressort de retour levier de dem.	Rückstellfeder starterhebel	Muelle de retorno palanca arr.
4	18.14620.800	1		Ingranaggio messa in moto	Kickstart gear	Pignon de démarrage	Startergetriebe	Engranaje del arranque
5	10.15120.800	1		Albero messa in moto	Kickstarter shaft	Arbre du démarreur	Starterwelle	Eje puesta en marcha
6	22.14090.800	1		Manicotto messa in moto	Kickstart sleeve	Manchon de démarrage	Muffe starter	Manguito arranque
7	27.61550.000	1		Rondella spess. C72	Washer 15x25 C72	Rondelle epaisseur 15x25 C72	Scheibe 15x25 C72	Arandela 15x25 C72
8	22.36570.000	1		Molla conica	Spring	R ressort conique	Muelle	Muelle
9	11.31020.000	1		Boccola sinterizzata 14.18.11,5	Bush 14.18.11,5	Bague 14.18.11,5	Sinterbuchse 14.18.11,5	Casquillo 14.18.11,5
10	10.52010.000	1		Anello paraolio 14.24.7	Oil seal 14.24.7	Joint d'étanchéité 14.24.7	Ölschutzring 14.24.7	Retén de aceite 14.24.7
11	004.06.000.82.00	1		Leva messa in moto completa	Start. lever	Levier de démarrage	Kickstarterhebel	Palanca de arranque
12	25.57945.800	1		Piastrina completa	Plate, assy.	Plaquette compl,	Plättchen kpl.	Placa completa
13	25.43910.000	1		Perno	Pin	Pivot	Zapfen	Perno
14	31.31050.000	1		Vite t.c.c.e.M6x15	Screw t.c.c.e.M6x15	Vis t.c.c.e.M6x15	Schraube t.c.c.e.M6x15	Tornillo t.c.c.e.M6x15
15	18.67810.000	1		Ingranaggio ozioso	Idle gear	Engrenage parasite	Zahnrad	Engranaje parásita

# Tav.9

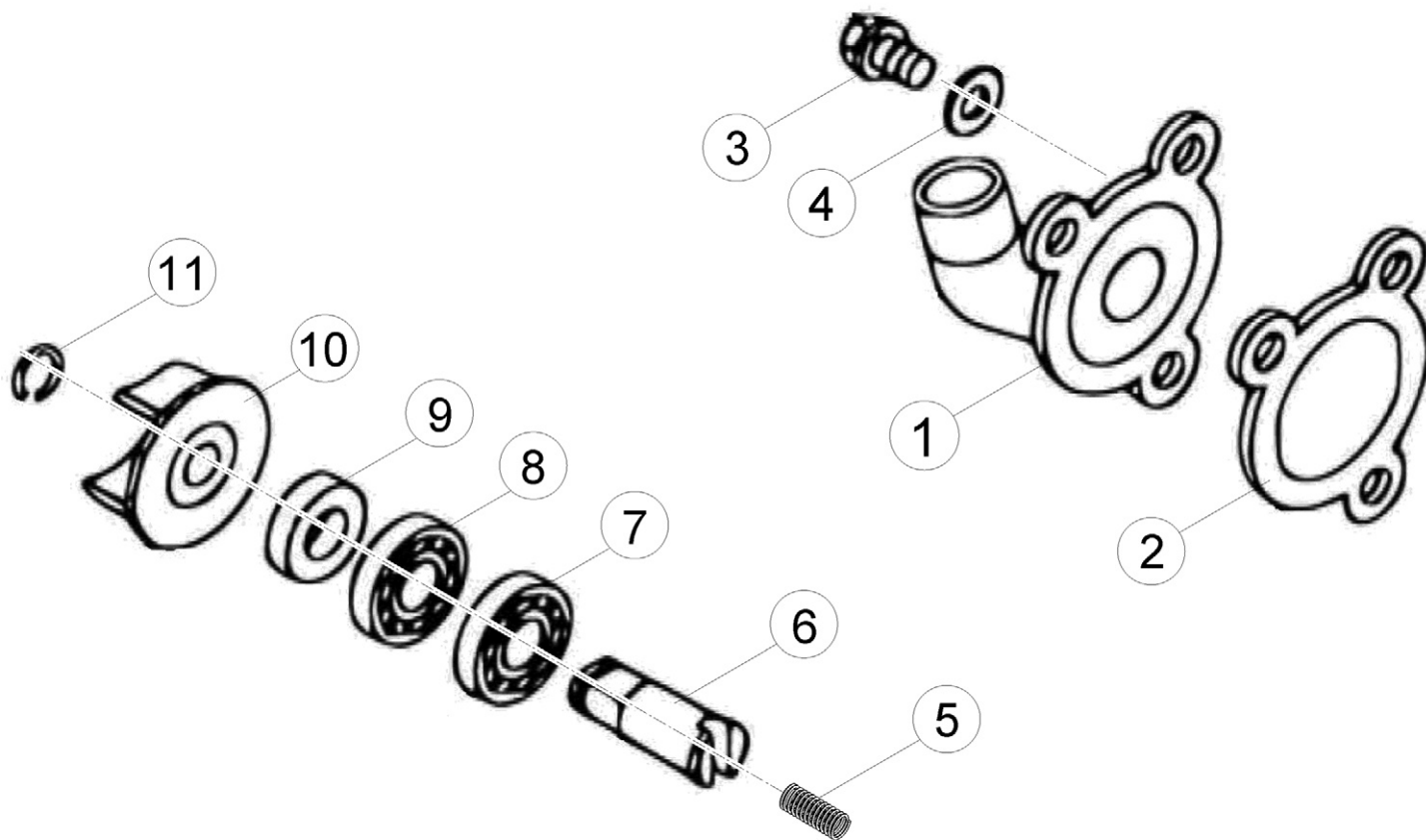

Pos Loc Pos Ps Pos	Numero Number Numéro Número Nummer	Q.tà Q.ty Q.té M.ge C.ad	Nota Note Note Nota Anm.	Descrizione	Description	Désignation	Beschreibung	Descripció
1	12.67941.033	1		Coperchio pompa	Pump cover	Couvercle pompe	Pumpendeckel	Tapa bomba
2	16.74930.000	1		Guarnizione coperchio pompa acqua	Water pump cover gasket	Joint couvercle pompe eau	Dichtung Wasserpumpeabdeckung	Junta tapa bomba agua
3	31.30510.000	1		Vite 6x30	Screw 6x30	Vis 6x30	Schraube 6x30	Tornillo 6x30
4	27.40490.000	1		Rondella in rame 6.10.2	Copper washer 6.10.2	Rondelle en cuivre 6.10.2	Kupfer U.Scheibe 6.10.2	Arandela de cobre 6.10.2
5	22.36580.000	1		Molla alberino	Shaft spring	Ressort arbre	Feder Welle	Muelle eje
6	10.27752.000	1		Albero pompa acqua	Coolant pump shaft	Arbre de pompe a eau	Wasserpumpenwelle	Eje bomba de agua
7	12.93390.000	1		Cuscinetto 10.19.5	Bearing 10.19.5	Roulement 10.19.5	Lager 10.19.5	Cojinete 10.19.5
8	12.93400.000	1		Cuscinetto 10x19.5	Bearing 10x19.5	Roulement 10x19.5	Lager 10x19.5	Cojinete 10x19.5
9	10.44610.000	1		Paraolio 10x18x4	Oil seal 10x18x4	Pare-huile 10x18x4	Dichtring 10x18x4	Sello de lub. 10x18x4
10	31.21831.000	1		Girante pompa acqua	Water pump fan	Couronne pompe eau	Läuferrad der Wasserpumpe	Rotor bomba agua
11	28.22660.000	1		Seeger 9E	Seeger 9E	Seeger 9E	Seegerring 9E	Seeger 9E

# Tav.10

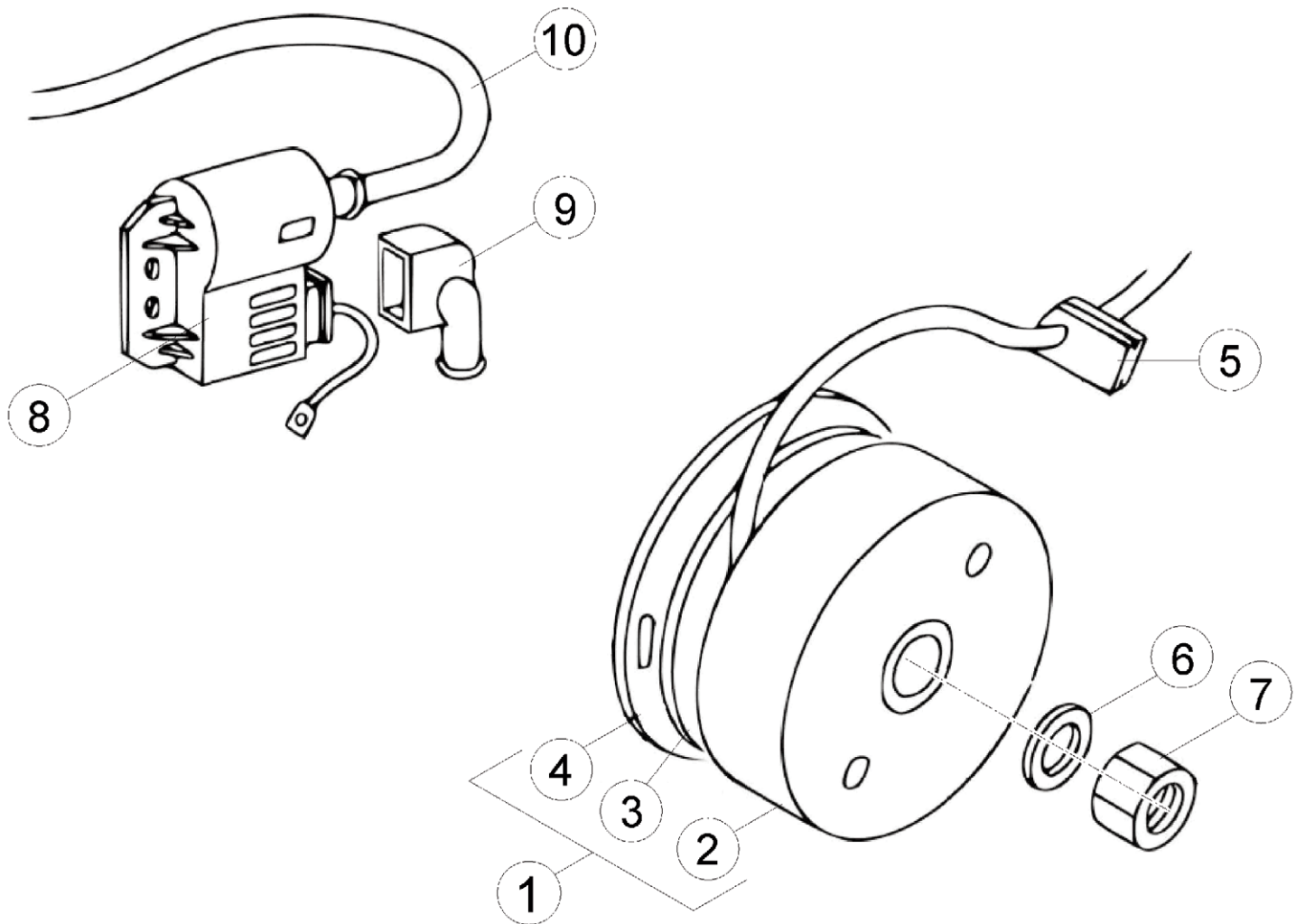

Pos Loc Pos Ps Pos	Numero Number Numéro Número Nummer	Q.tà Q.ty Q.té M.ge C.ad	Nota Note Note Nota Anm.	Descrizione	Description	Désignation	Beschreibung	Descripcìon
1	31.03271.000	1		Volano	Flywheel	Volant	Lichtmaschine	Volante
2	27.00376.000	1		Rotore volano	Flywheel rotor	Rotor volant	Rotor schwungrad	Rotor volante
3	28.97815.000	1		Statore volano	Alternator stator	Stator volant	Stator schwungrad	Placa del volante
4	25.60163.000	1		Piastrina statore	Backplate plate	Plateau stator	Ankerplatte platte	Placa del estator
5	16.33553.000	1		Gommino fissaggio cavi	Rubber pad	Pièce caoutchouc	Gummistück	Goma
6	27.52500.000	1		Rondella grower 10	Grower washer 10	Rondelle Grower 10	Federring Grower 10	Arandela elástica Grower 10
7	13.25100.000	1		Dado speciale 10.1,25.17 ch15	Special nut 10.1,25.17 ch15	Ecrou spéciale 10.1,25.17 ch15	Spezialmutter 10.1,25.17 ch15	Tuerca especial 10.1,25.17 ch15
8	11.20681.000	1		Bobina	Coil	Bobine	Spule	Bobina
9	12.30460.000	1		Cappuccio cavo bobina	Coil cable rubber protector	Capuchon cable bobine	Kappe Zündspulen kabel	Capuchon cable bobina
10	12.08280.000	1		Cavo bobina schermato	Screened coil cable	Câble bobine anti-parasité	abgeschirmtes Spulen kabel	Cable bobina protegido

# Tav.11

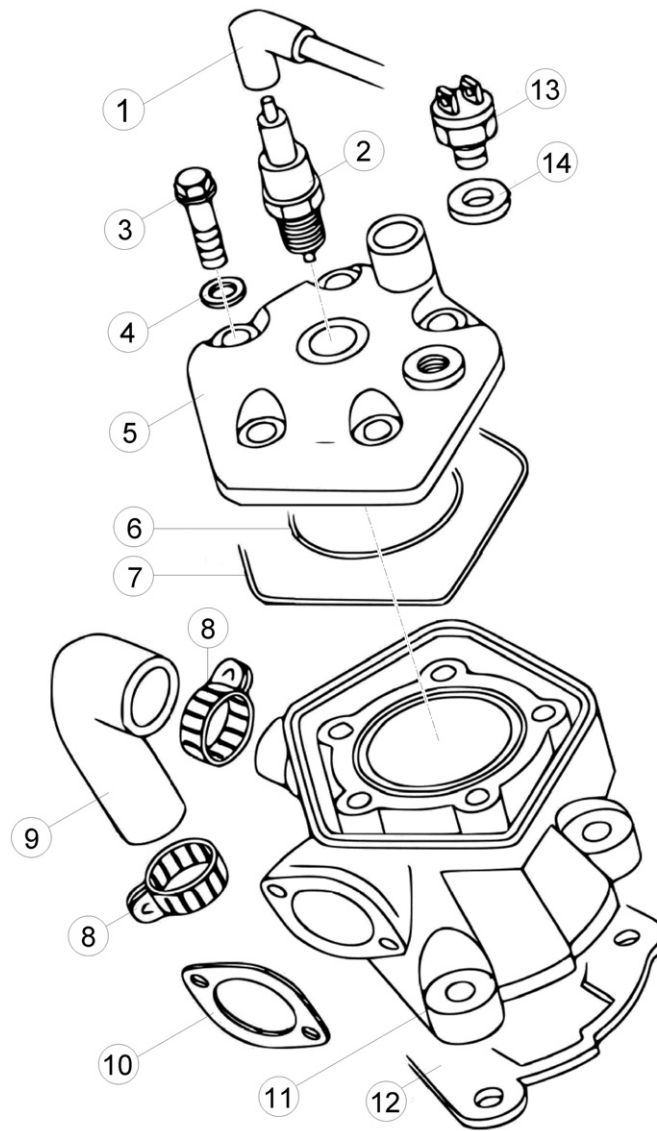

Pos Loc Pos Ps Pos	Numero Number Numéro Número Nummer	Q.tà Q.ty Q.té M.ge C.ad	Nota Note Note Nota Anm.	Descrizione	Description	Désignation	Beschreibung	Descripció
1	27.13514.000	1		Raccordo candela	Plug fitting	Raccord bougie	Kerzenanschluß	Racor bujia
2	12.25200.000	1		Candela m3c	Spark.plug m3c	Bougie m3c	Zündkerze m3c	Bujia m3c
3	11.52425.000	5		Bullone speciale 7x33	Special bolt 7x33	Boulon spéciale 7x33	Spezialschraube 7x33	Tornillo especial 7x33
4	27.45100.000	5		Rondella in rame 7x12x0,5	Copper washer 7x12x0,5	Rondelle en cuivre 7x12x0,5	Kupfer U.Scheibe 7x12x0,5	Arandela de cobre 7x12x0,5
5	29.12025.057	1		Testa d.48	Cylinder head d.48	Culasse d.48	Kopf d.48	Culata d.48
6	10.67050.000	1		Anello or 51,50x1,78	O-Ring 51,50x1,78	Bague d'étanchéité 51,50x1,78	O-Ring 51,50x1,78	Anillo OR 51,50x1,78
7	10.66960.000	1		Anello or 94,97.98,53	O-Ring 94,97.98,53	Bague d'étanchéité 94,97.98,53	O-Ring 94,97.98,53	Anillo OR 94,97.98,53
8	15.15228.000	2		Fascetta 14x24	Clamp 14x24	Collier 14x24	Schelle 14x24	Abrazadera 14x24
9	29.15910.000	1		Tubo raffreddamento	Cooling tube	Tuyau de refroid.	Kühlleitung	Conducto refriger.
10	16.80321.000	1	Senior	Guarnizione scarico	Exhaust manifold gasket	Joint coll. Ech.	Dichtung Abgaskrümmer	Junta colector de escape
10	16.80323.000	1	Junior	Guarnizione scarico	Exhaust manifold gasket	Joint coll. Ech.	Dichtung Abgaskrümmer	Junta colector de escape
11	12.52463.057	1		Cilindro d.48	Cylinder d.48	Cylindre d.48	Zylinder d.48	Cilindro d.48
12	16.61750.000	1		Guarnizione cilindro-carter	Crankcase-cylinder packing	Joint d'embase	Dichtung Zylinder-Motorgehäuse	Junta cilindro-carter
13	16.49500.000	1		Guarnizione rame 8.20.1	Copper gasket 8.20.1	Joint cuivre 8.20.1	Kupferdichtung 8.20.1	Junta de cobre 8.20.1
14	29.11960.000	1		Termointerruttore	Thermal switch	Thermo-régulateur	Umschalter	Interruptor térmico

# Tav.12

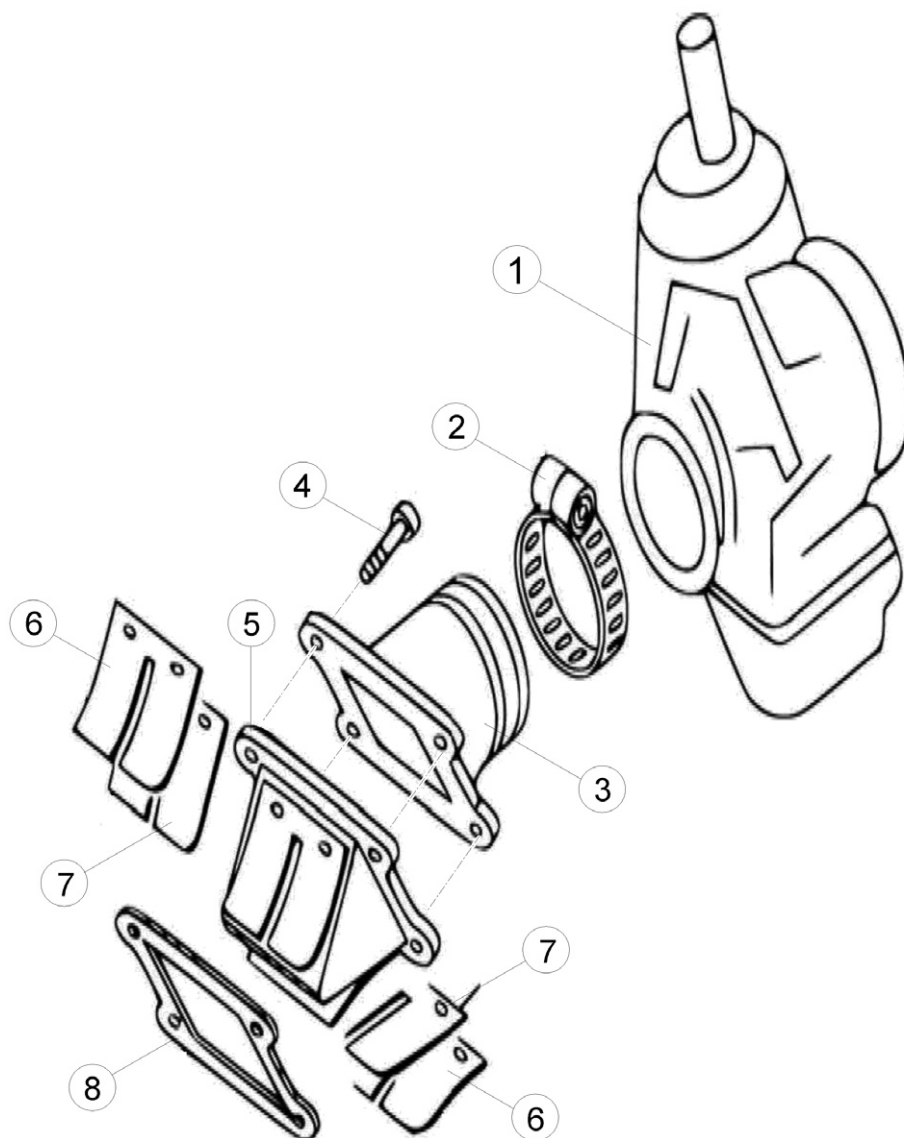

Pos Loc Pos Ps Pos	Numero Number Numéro Número Nummer	Q.tà Q.ty Q.té M.ge C.ad	Nota Note Note Nota Anm.	Descrizione	Description	Désignation	Beschreibung	Descripcìon
1	12.05068.000	1		Carburatore phbg 21	Carburettor phbg 21	Carburateur phbg 21	Vergaser phbg 21	Carburador phbg 21
2	15.15370.000	1		Fascetta 20/32	Clamp 20/32	Collier 20/32	Schelle 20/32	Abrazadera 20/32
3	27.23051.000	1		Raccordo carburatore	Carburettor Union	Raccord Carburateur	Vergaseranschluss	Empalme Carburador
4	31.34510.000	4		Vite t.c.c.e. M6x20	Screw t.c.c.e. M6x20	Vis t.c.c.e. M6x20	Schraube t.c.c.e. M6x20	Tornillo t.c.c.e. M6x20
5	31.02140.000	1		Valvola completa	Valve, assy.	Soupape complète	Ventil, kompl.	Válvula completa
6	25.59670.000	1		Piastrina	Plate	Plaquette	Plättchen	Placa
7	21.15360.000	1		Lamella	Plaque	Lame	Lamellen	Pletina
8	16.92550.000	1		Guarnizione valvola	Valve gasket	Joint soupape	Ventildichtung	Junta válvula

# Tav.31

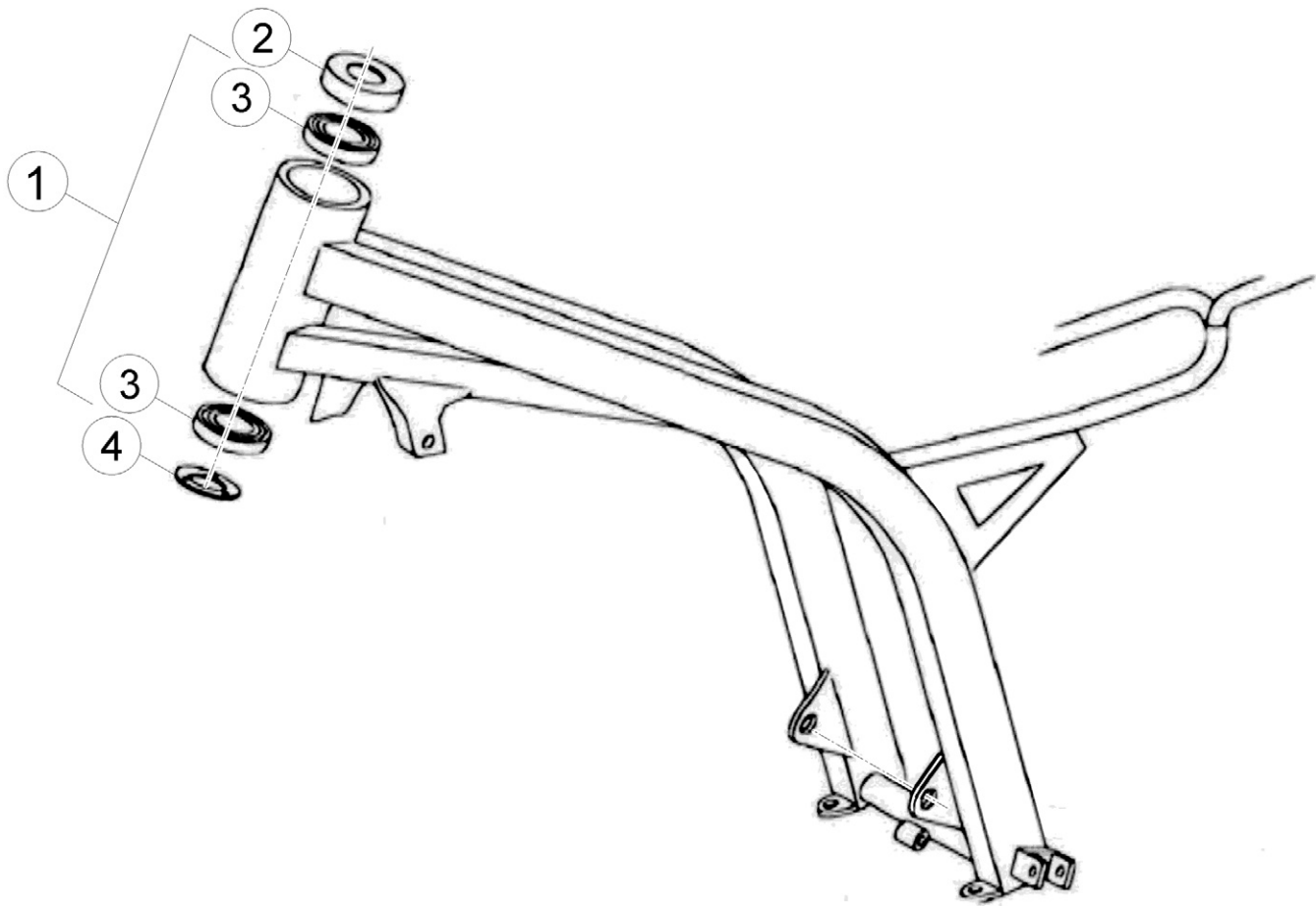

Pos Loc Pos Ps Pos	Numero Number Numéro Número Nummer	Q.tà Q.ty Q.té M.ge C.ad	Nota Note Note Nota Anm.	Descrizione	Description	Désignation	Beschreibung	Descripció
1	012.31.001.80.51	1	Junior	Telaio anteriore	Front frame	Cadre avant	Gutschrift Rahmen	Chasis
1	012.31.002.80.51	1	Senior	Telaio anteriore	Front frame	Cadre avant	Gutschrift Rahmen	Chasis
2	25.98670.000	1		Protezione cuscinetto sterzo	Ball-bearing protection	Protection roulement guidon	Abdeckung Lenkerslager	Proteccion cojinete manillar
3	12.98300.000	2		Cuscinetto conico 20x42x15	Conical bearing 20x42x15	Roulement conique 20x42x15	Lager 20x42x15	Cojinete conico 20x42x15
4	25.98752.000	1		Protezione cuscinetto sterzo	Ball-bearing protection	Protection roulement guidon	Abdeckung Lenkerslager	Proteccion cojinete manillar



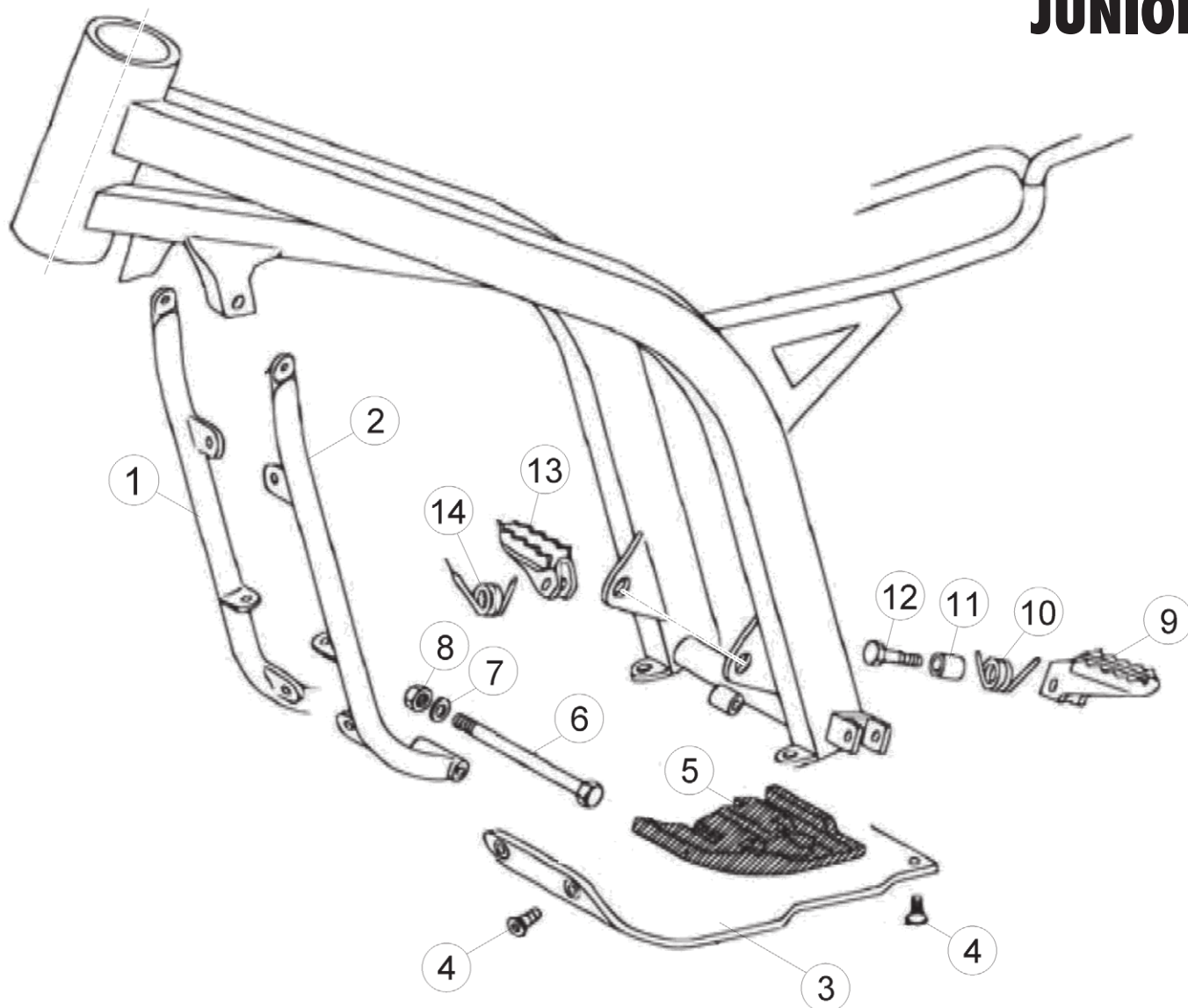

Pos Loc Pos Ps Pos	Numero Number Numéro Número Nummer	Q.tà Q.ty Q.té M.ge C.ad	Nota Note Note Nota Anm.	Descrizione	Description	Désignation	Beschreibung	Descripcìon
1	012.32.000.40.51	1		Supporto motore dx	RH engine support bracket	Bride support moteur D.	Motorsattelbefestigung rechts	Brida soporte motor der.
2	032.31.168.40.51	1		Supporto motore sx	LH engine support bracket	Bride support moteur G.	Motorsattelbefestigung links	Brida soporte motor izq.
3	12.32172.000	1		Protezione inferiore motore	Lower engine protection	Protection Inf. Moteur	Unterer Motorschutz	Protección inferior motor
4	31.63930.000	4		Vite TSPCE 8.20	Screw TSPCE 8.20	Vis TSPCE 8.20	Schraube TSPCE 8.20	Tornillo TSPCE 8.20
5	16.23342.000	1		Gomma carter parasassi	Bumber rubber	Caoutchouc sabot moteur	Bodenplatte Gummi	Goma proteccion carter
6	11.57990.000	1		Bullone 8.180 pf ch13 rs	Bolt 8.180 pf ch13 rs	Boulon 8.180 pf ch13 rs	Bolzen 8.180 pf ch13 rs	Tornillo 8.180 pf ch13 rs
7	27.49500.000	1		Rondella 8x18	Washer 8x18	Rondelle 8x18	U.Scheibe 8x18	Arandela 8x18
8	13.17020.000	1		Dado autobloccante M8	Self locking nut M8	Ecrou de sécurité M8	Mutter, selbstsichernd M8	Tuerca de seguridad M8
9	25.32530.000	1		Pedana poggiapiedi sx	LH footrest	Repose-pieds gauche	Fußraste li.	Estribera izq.
10	22.62020.000	1		Molla pedana sx	L.H. footrest spring	Ressort repose-pied gauche	Rasten/Feder li.	Muelle izqui. Estribera
11	13.46530.000	2		Distanziale 8x12x17	Spacer 8x12x17	Entretoise 8x12x17	Distanz 8x12x17	Distanciadore 8x12x17
12	11.55690.000	2		Bullone M8x45 RS CH 10	Bolt M8x45 RS CH 10	Boulon M8x45 RS CH 10	Bolzen M8x45 RS CH 10	Tornillo M8x45 RS CH 10
13	25.32520.000	1		Pedana poggiapiedi dx	RH footrest	Repose-pieds droit	Fußraste re.	Estribera dhc
14	22.62010.000	1		Molla pedana dx	R.H. footrest spring	Ressort repose-pied droit	Rasten/Feder re.	Muelle derch. Estribera

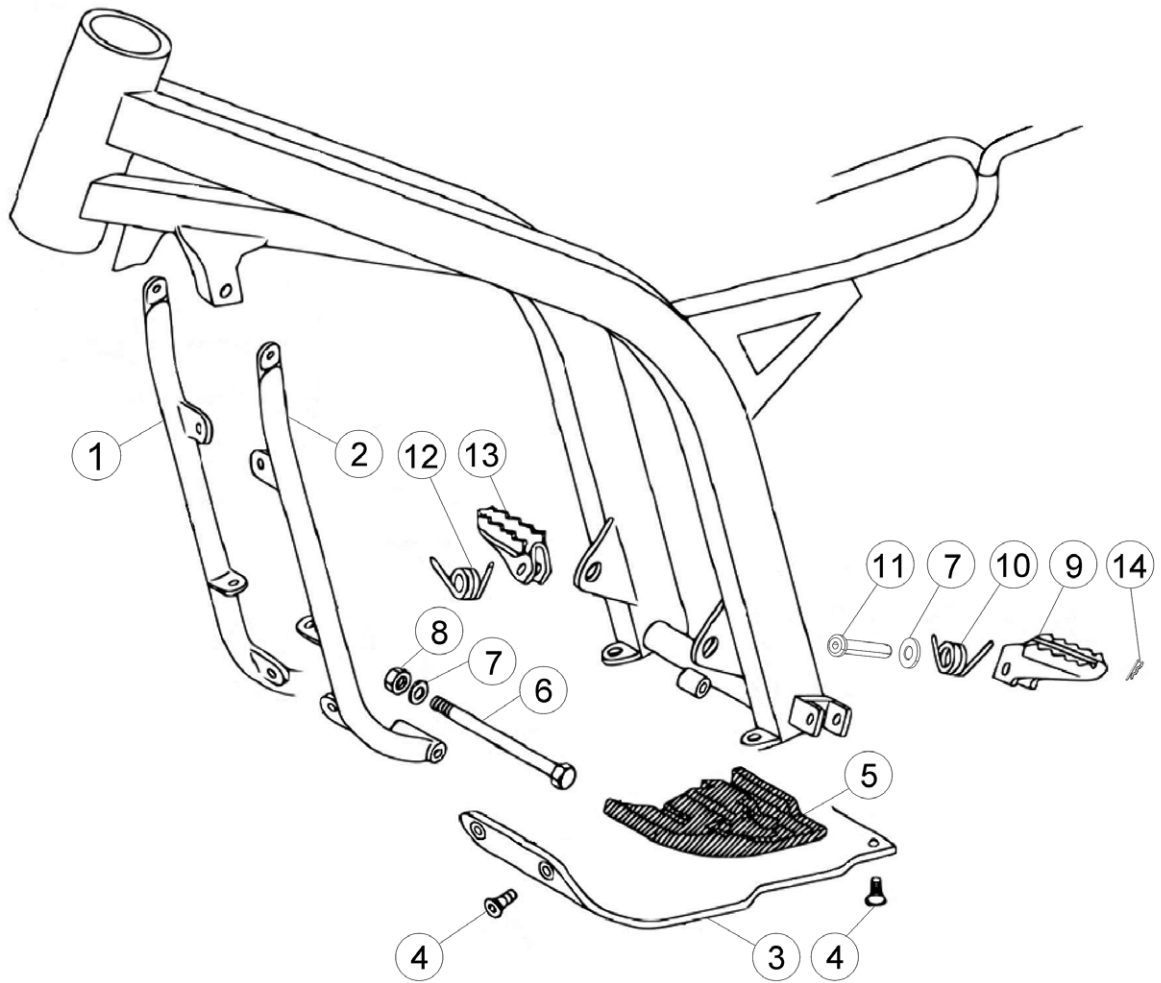

# Tav.32B

Pos Loc Pos Ps Pos	Numero Number Numéro Número Nummer	Q.tà Q.ty Q.té M.ge C.ad	Nota Note Note Nota Anm.	Descrizione	Description	Désignation	Beschreibung	Descrìpion
								<b>SENIOR</b>
1	012.32.000.40.51	1		Supporto motore dx	RH engine support bracket	Bride support moteur D.	Motorsattelbefestigung rechts	Brida soporte motor der.
2	032.31.168.40.51	1		Supporto motore sx	LH engine support bracket	Bride support moteur G.	Motorsattelbefestigung links	Brida soporte motor izq.
3	12.32172.000	1		Protezione motore	Engine protection	Protection Moteur	Motorschutz	Protección motor
4	31.63930.000	4		Vite TSPCE 8.20	Screw TSPCE 8.20	Vis TSPCE 8.20	Schraube TSPCE 8.20	Tornillo TSPCE 8.20
5	16.23342.000	1		Gomma carter parasassi	Bumber rubber	Caoutchouc sabot moteur	Bodenplatte Gummi	Goma protección carter
6	11.57900.000	1		Bullone 8.180 pf ch13 rs	Bolt 8.180 pf ch13 rs	Boulon 8.180 pf ch13 rs	Bolzen 8.180 pf ch13 rs	Tornillo 8.180 pf ch13 rs
7	27.49500.000	3		Rondella 8x16	Washer 8x16	Rondelle 8x16	U.Scheibe 8x16	Arandela 8x16
8	13.17020.000	1		Dado autobloccante M8	Self locking nut M8	Ecrou de sécurité M8	Mutter, selbstsichernd M8	Tuerca de seguridad M8
9	007.32.091.00.00	1		Pedana Poggiapiedi sx.	L.H. foot peg	Repose-pied gauche	Fussraste links	Estribera Izq.
10	22.62020.000	1		Molla pedana sx	L.H. footrest spring	Ressort repose-pied gauche	Rasten/Feder li.	Muelle izqui. Estribera
11	25.54466.000	2		Perno	Pin	Pivot	Zapfen	Perno
12	22.62010.000	1		Molla pedana dx	R.H. footrest spring	Ressort repose-pied droit	Rasten/Feder re.	Muelle derch. Estribera
13	007.32.090.00.00	1		Pedana poggiapiedi dx.	R.H. foot peg	Repose-pied droit	Fussraste rechts	Estribera Der.
14	12.81995.000	2		Copiglia 2x15	Split pin 2x15	Goupille 2x15	Splint 2x15	Grupilla 2x15

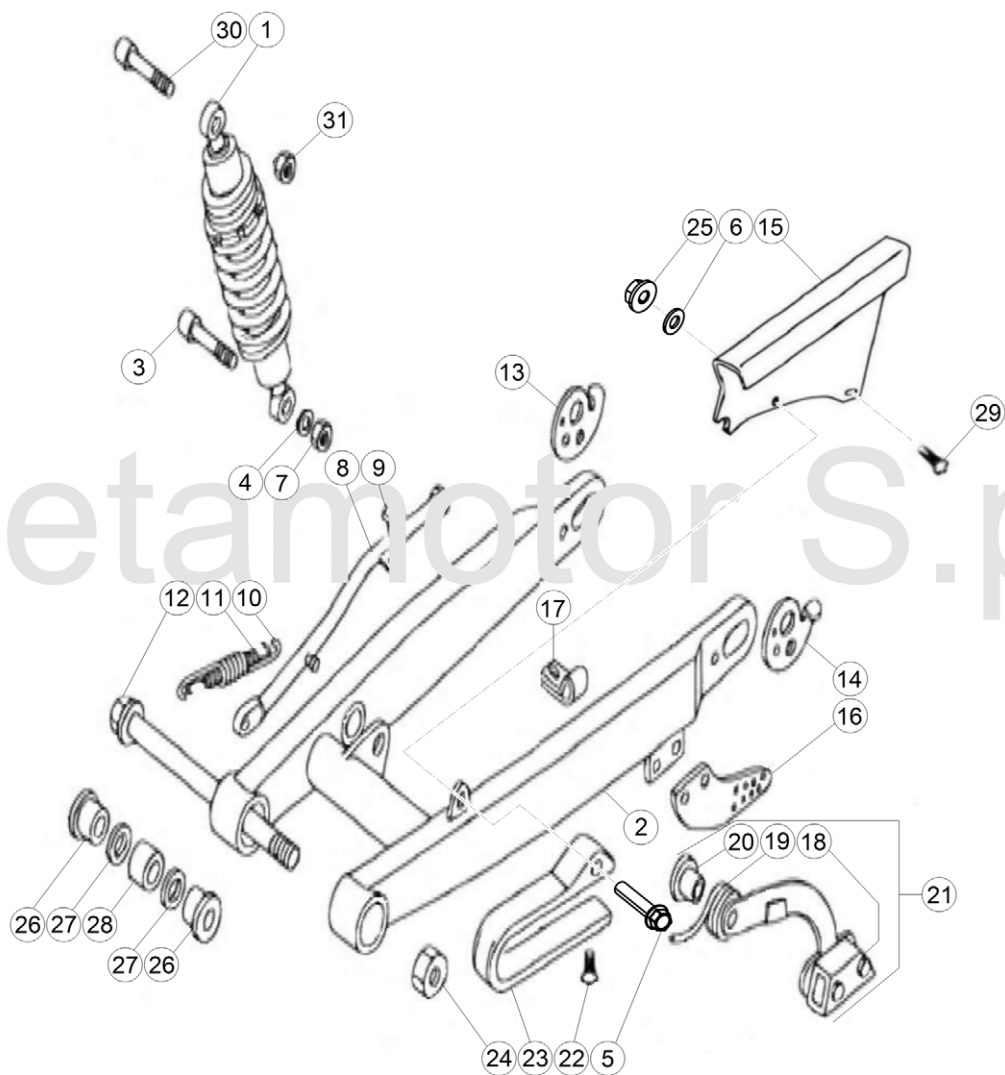

© Copyright 2019 Betamotor S.p.A.



# Tav.33A

Pos Loc Pos Ps Pos	Numero Number Numéro Número Nummer	Q.tà Q.ty Q.té M.ge C.ad	Nota Note Note Nota Anm.	Descrizione	Description	Désignation	Beschreibung	Descripcìon
								<b>JUNIOR</b>
1	012.33.001.80.00	1		Ammortizzatore	Damper	Amortisseur	Stoßdämpfer	Amortiguador
2	032.33.109.40.51	1		Forcellone	Big fork	Fourche	Radschwinge	Horquilla
3	31.65510.000	1		Vite tcce 10.55	Screw tcce 10.55	Vis tcce 10.55	Schraube tcce 10.55	Tornillo tcce 10.55
4	27.54000.000	1		Rondella 10x21x2	Washer 10x21x2	Rondelle 10x21x2	U.Scheibe 10x21x2	Arandela 10x21x2
5	11.50360.000	1		Bullone 6.40 RS CH8	Bolt 6.40 RS CH8	Boulon 6.40 RS CH8	Bolzen 6.40 RS CH8	Tornillo 6.40 RS CH8
6	27.40500.000	1		Rosetta piana 6.12.1,6 DIN 125	Washer 6.12.1,6 DIN 125	Rondelle 6.12.1,6 DIN 125	U.Scheibe 6.12.1,6 DIN 125	Arandela 6.12.1,6 DIN 125
7	13.19010.000	1		Dado autoblocc. Basso M10	Nut M10	Ecrou M10	Mutter M10	Tuerca M10
8	12.39971.000	1		Cavalletto	Central stand	Béquille	Kippständer	Caballote
9	16.29489.000	1		Gommino battuta cavalletto	Stand stop rubber	Caoutchouc butée béquille	Anschlaggummi Ständer	Goma tope caballete
10	22.47022.000	1		Molla cavalletto esterna	External stand spring	Ressort bequille extérieure	Seitenständer feder außen	Muelle caballete exterior
11	22.47019.000	1		Molla cavalletto interna	Inner stand spring	Ressort bequille intérieure	Seitenständer feder innen	Muelle caballete interior
12	25.55725.000	1		Perno forcellone	Swingarm pivot	Axe fourche AR.	Schwingenbolzen	Eje basculante
13	29.11892.000	1		Tendicatena dx	R.H. chain adjuster	Tendeur de chaîne D.	Kettenspanner rechts	Tensor de cadena der.
14	29.11891.000	1		Tendicatena sx	L.H. chain adjuster	Tendeur de chaîne G.	Kettenspanner links	Tensor de cadena izq.
15	12.84771.052	1		Copricatena	Chain guard	Carter de chaîne	Kettenabdeckung	Cubre-cadena
16	25.98955.000	1		Protezione corona	Ring gear protection	Protection couronne dentée	Zahnkranzschutz	Protección corona
17	15.14653.000	1		Fascetta	Clamp	Collier	Schelle	Abrazadera
18	16.22500.000	1		Gomma pattino guida catena	Chain guide shoe rubber	Caoutchouc doigt guide-chaîne	Gummistück Gleitauflage	Goma patín guía cadena
19	22.81111.000	1		Molla rit. pattino guida catena	Chain guide shoe pullback spring	Ressort reten. doigt guide-chaîne	Rückzugsfeder Gleitauflage	Muelle retención patín guía
20	13.46314.000	1		Distanziale	Spacer	Entretoise	Distanzstück	Distanciador
21	25.25970.000	1		Tendicatena completo	Chain tightener assy.	Tendeur de chaîne compet	Kettenspanner komplett	Tensor de cadena compl.
22	31.30500.000	1		Vite M6x12 TSPCE	Screw M6x12 TSPCE	Vis M6x12 TSPCE	Schraube M6x12 TSPCE	Tornillo M6x12 TSPCE
23	29.10093.052	1		Tassello guidacatena super.	Upper sliding block	Cheville guide de chaîne sup.	Schwingenschleifklotz oben	Protector cadena superior
24	13.21155.000	1		Dado flangiato M12 p. 1,25	Nut M12 p. 1,25	Ecrou M12 p. 1,25	Mutter M12 p. 1,25	Tuerca M12 p. 1,25
25	13.13020.000	1		Dado autobloccante basso M6	Nut M6	Ecrou M6	Mutter M6	Tuerca M6
26	13.49201.000	4		Distanziale forcellone	Big fork spacer	Entretoise fourche	Distanzstück Radschwinge	Distanciador horquilla
27	10.41195.000	4		Anello parapolvere 20x26x4	Dust cover 20x26x4	Disque pare-poussière 20x26x4	Staubdeckel 20x26x4	Disco gurdapolvo 20x26x4
28	11.22850.000	4		Boccola a rulli	Roller bush	Bague	Sinterbuchse	Casquillo
29	31.30530.000	1		Vite TTLIC M6.12 testa 15	Screw TTLIC M6.12 head 15	Vis TTLIC M6.12 tête 10	Schraube TTLIC M6.12	Tornillo TTLIC M6.12 cabeza 15
30	11.62060.000	1		Bullone M10x50 p 1.25 (10.9)	Bolt M10x50 p 1.25 (10.9)	Boulon M10x50 p 1.25 (10.9)	Bolzen M10x50 p 1.25 (10.9)	Tornillo M10x50 p 1.25 (10.9)
31	13.21060.000	1		Dado autoblocc. M10 p1,25 CH14	Self locking nut M10 p1,25 CH14	Ecrou autob. M10 p1,25 CH14	Mutter M10 p1,25 CH14	Tuerca M10 p1,25 CH14

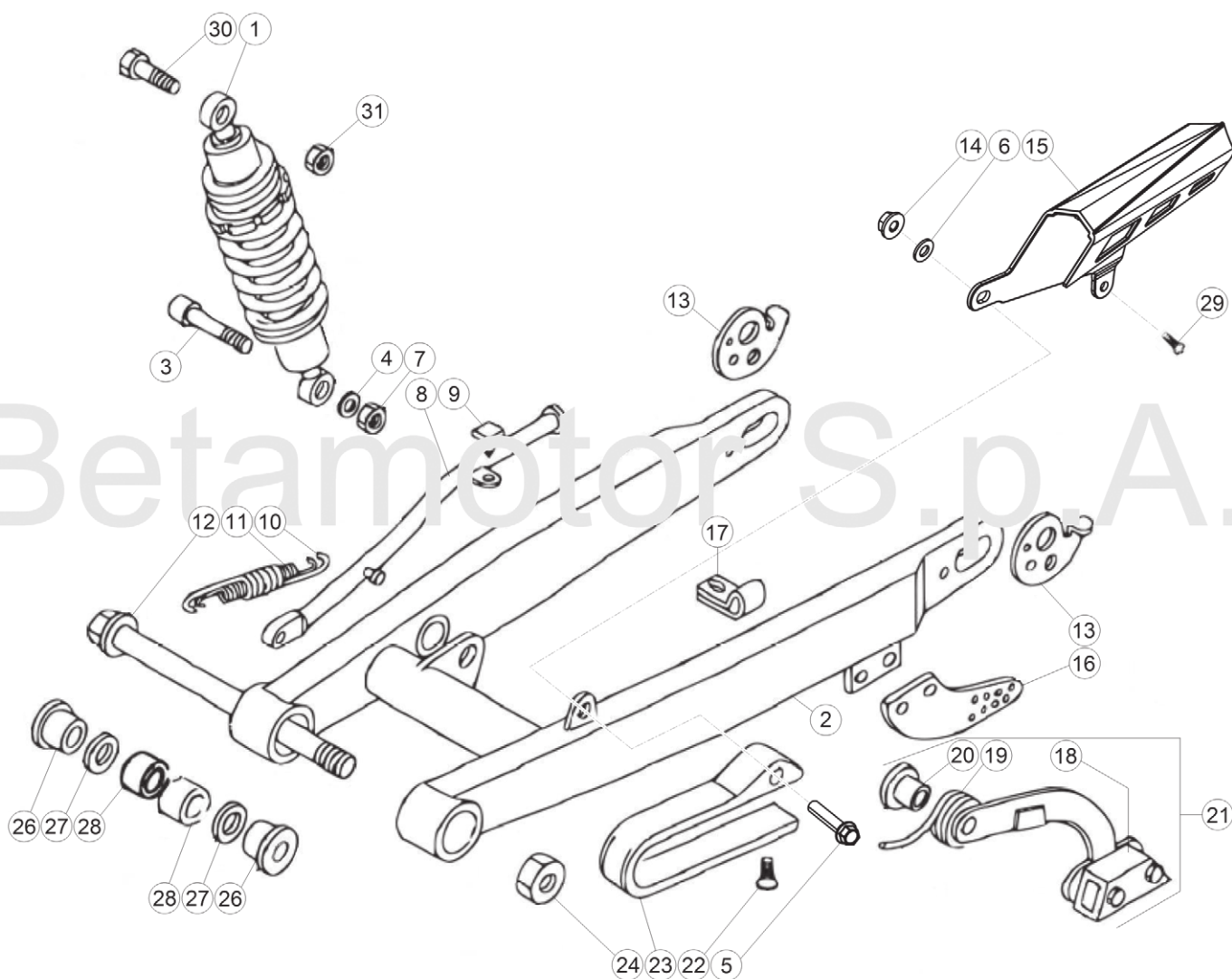

© Copyright 2019 Betamotor S.p.A.



# Tav.33B

Pos Loc Pos Ps Pos	Numero Number Numéro Número Nummer	Q.tà Q.ty Q.té M.ge C.ad	Nota Note Note Nota Anm.	Descrizione	Description	Désignation	Beschreibung	Descrìcion
								<b>SENIOR</b>
1	012.33.000.80.00	1		Ammortizzatore	Damper	Amortisseur	Stoßdämpfer	Amortiguador
2	012.33.003.40.51	1		Forcellone	Big fork	Fourche	Radschwinge	Horquilla
3	31.65510.000	1		Vite tcce 10.55	Screw tcce 10.55	Vis tcce 10.55	Schraube tcce 10.55	Tornillo tcce 10.55
4	27.54000.000	1		Rondella 10x21x2	Washer 10x21x2	Rondelle 10x21x2	U.Scheibe 10x21x2	Arandela 10x21x2
5	11.50360.000	1		Bullone 6.40 RS CH8	Bolt 6.40 RS CH8	Boulon 6.40 RS CH8	Bolzen 6.40 RS CH8	Tornillo 6.40 RS CH8
6	27.40500.000	1		Rosetta piana 6.12.1,6 DIN 125	Washer 6.12.1,6 DIN 125	Rondelle 6.12.1,6 DIN 125	U.Scheibe 6.12.1,6 DIN 125	Arandela 6.12.1,6 DIN 125
7	13.19010.000	1		Dado autoblocc. Basso M10	Nut M10	Ecrou M10	Mutter M10	Tuerca M10
8	12.39972.000	1		Cavalletto	Central stand	Béquille	Kippständer	Caballete
9	16.29489.000	1		Gommino battuta cavalletto	Stand stop rubber	Caoutchouc butée béquille	Anschlaggummi Ständer	Goma tope caballete
10	22.47022.000	1		Molla cavalletto esterna	External stand spring	Ressort bequille exterieure	Seitenständer feder außen	Muelle caballete exterior
11	22.47019.000	1		Molla cavalletto interna	Inner stand spring	Ressort bequille interieure	Seitenständer feder innen	Muelle caballete interior
12	25.55725.000	1		Perno forcellone	Swingarm pivot	Axe fourche AR.	Schwingebolzen	Eje basculante
13	29.11860.000	2		Tendicatena	Chain tightener	Tend. de ch.	Kettenspanner	Tens. de cad.
14	13.13020.000	1		Dado autobloccante basso M6	Nut M6	Ecrou M6	Mutter M6	Tuerca M6
15	008.33.050.10.59	1		Copricatena	Chain guard	Carter de chaîne	Kettenabdeckung	Cubre-cadena
16	25.98955.000	1		Protezione corona	Ring gear protection	Protection couronne dentee	Zahnkranzschutz	Protección corona
17	15.14655.000	1		Fascetta tubo freno	Brake pipe clamp	Collier tube frein disque	Schelle F. Bremsschlauch	Brida fijacion tubo freno
18	16.22500.000	1		Gomma pattino guida catena	Chain guide shoe rubber	Caoutchouc doigt guide-chaîne	Gummistück Gleitauflage	Goma patín guía cadena
19	22.81111.000	1		Molla rit. pattino guida catena	Chain guide shoe pullback spring	Ressort retenue doigt guide-chaîne	Rückzugsfeder Gleitauflage	Muelle retención patín guía cadena
20	13.46314.000	1		Distanziale	Spacer	Entretoise	Distanzstück	Distanciadador
21	25.25970.000	1		Tendicatena completo	Chain tightener assy.	Tendeur de chaîne compet	Kettenspanner komplett	Tensor de cadena compl.
22	31.30500.000	1		Vite M6x12 TSPCE	Screw M6x12 TSPCE	Vis M6x12 TSPCE	Schraube M6x12 TSPCE	Tornillo M6x12 TSPCE
23	29.10093.052	1		Tassello guidacatena super.	Upper sliding block	Cheville guide de chaîne sup.	Schwingschleifklotz oben	Protector cadena superior
24	13.21155.000	1		Dado flangiato M12 p. 1,25	Nut M12 p. 1,25	Ecrou M12 p. 1,25	Mutter M12 p. 1,25	Tuerca M12 p. 1,25
26	13.49201.000	4		Distanziale forcellone	Big fork spacer	Entretoise fourche	Distanzstück Radschwinge	Distanciadador horquilla
27	10.41195.000	4		Anello parapolvere 20x26x4	Dust cover 20x26x4	Disque pare-poussière 20x26x4	Staubdeckel 20x26x4	Disco gurdapolvere 20x26x4
28	11.22850.000	2		Boccola a rullini 20x26x12	Roller cage 20x26x12	Cage Aiguille 20x26x12	Rollenkäfig 20x26x12	Jaula rodillos 20x26x12
29	31.30080.000	1		Vite TTLIC M5.10 testa 10	Screw M5.10 head 10	Vis TTLIC M5.10 tête 10	Schraube M5.10	Tornillo M5.10 cabeza 10
30	11.62060.000	1		Bullone M10x50 p 1.25 (10.9)	Bolt M10x50 p 1.25 (10.9)	Boulon M10x50 p 1.25 (10.9)	Bolzen M10x50 p 1.25 (10.9)	Tornillo M10x50 p 1.25 (10.9)
31	13.21060.000	1		Dado autoblocc. M10 p1,25 CH14	Self locking nut M10 p1,25 CH14	Ecrou autob. M10 p1,25 CH14	Mutter M10 p1,25 CH14	Tuerca M10 p1,25 CH14

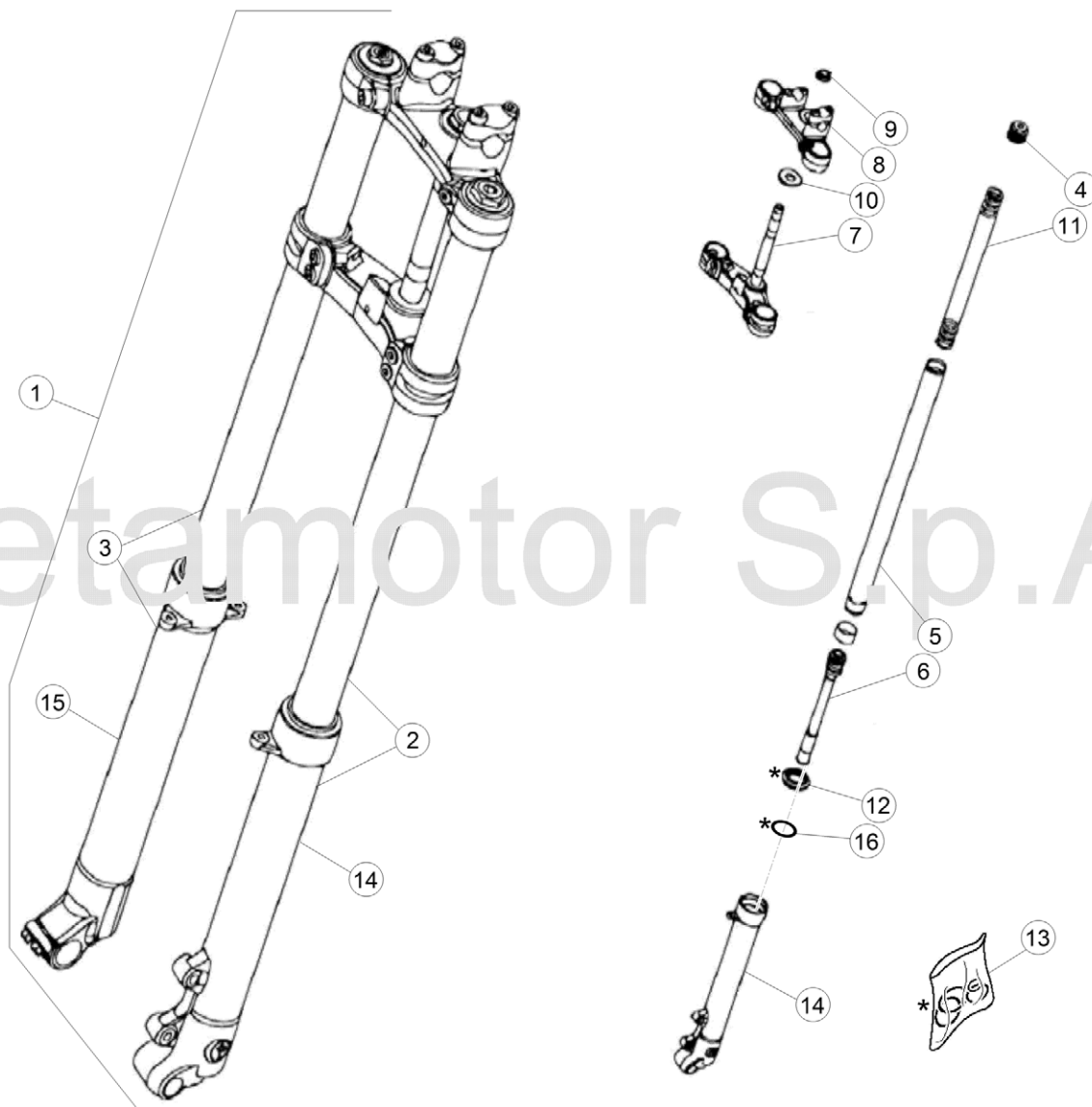

© Copyright 2017 Betamotor S.p.A.



# Tav.34A

Pos Loc Ps Pos	Numero Number Numéro Número Nummer	Q.tà Q.ty Q.té M.ge C.ad	Nota Note Note Nota Anm.	Descrizione	Description	Désignation	Beschreibung	Descrìcion
								<b>JUNIOR</b>
1	012.34.005.80.00	1		Forcella completa	Stirrup assy.	Fourchette compl.	Schaltgabel, Kompl.	Horquilla compl.
2	012.34.032.80.00	1		Gamba SX	LH leg	Tube G.	Linke Beineinheit	Pata izquierda
3	012.34.031.80.00	1		Gamba DX	RH leg	Tube D.	Rechte Beineinheit	Pata derecha
4	012.34.024.00.00	2		Tappo	Plug	Bouchon	Verschluß	Tapón
5	012.34.025.00.00	2		Tubo	Tube	Tuyau	Schlauch	Tubo
6	012.34.026.00.00	2		Cartuccia meccanica	Mechanical cartridge	Cartouche amort.	Mechanische Hülle	Cartucho mecanico
7	012.34.029.00.00	1		Piastra inf. con canotto	Lower plate with pin	Plaque inférieure avec pivot	Platte unter mit Bolzen	Chapa inferior con perno
8	012.34.028.00.00	1		Piastra superiore	Upper plate	Plaque supérieure	Plättchen oben	Chapa superior
9	012.34.030.00.00	1		Dado	Nut	Ecrou	Mutter	Tuerca
10	012.34.027.00.00	1		Ghiera canotto forcella	Steering collar	Collier tete inf. Fourche	Mutter Steuerkopf	Ghiera horquilla
11	012.34.021.00.00	2		Molla forcella	Fork spring	Ressort fourche	Gabelfeder	Muelle horquilla
12	012.34.033.00.00	2		Parapolvere	Dust cover	Pare-pouss.	Staubdeckel	Guardapolvo
13	012.34.020.82.00	1		Kit anelli di tenuta	Seal ring kit	Kit bague de retenue	Dichtringkit	Kit anillo de retención
14	012.34.023.00.00	1		Fodero SX	Sleeve L.H.	Protection Gauche	Schutzstück Linke	Protección Izq.
15	012.34.022.00.00	1		Fodero DX	Sleeve R.H.	Protection Droit	Schutzstück Recht	Protección Der
16	012.34.034.00.00	2		Anello di tenuta	Oil seal	Joint spie	Dichtring	Retén de aceite

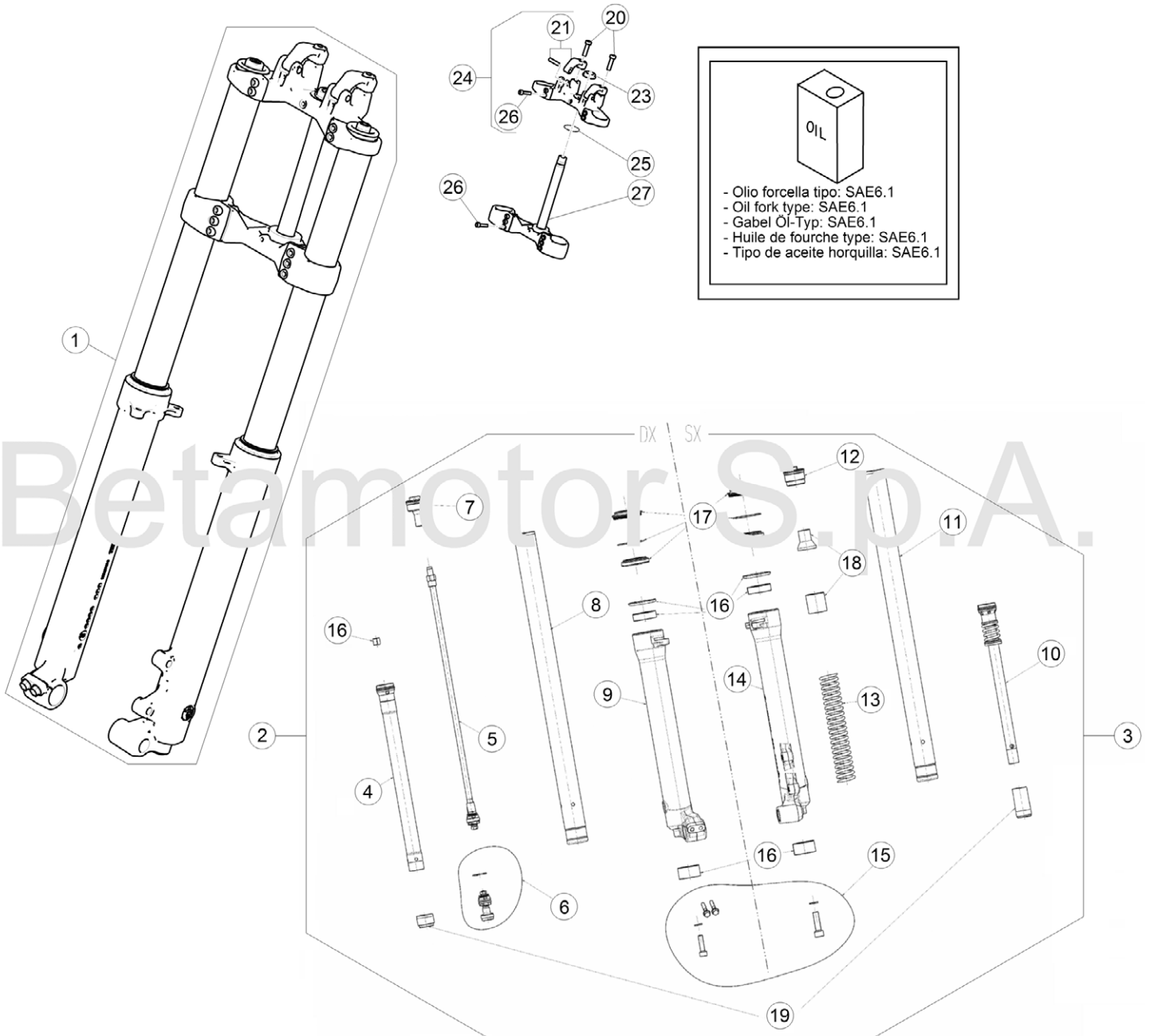

© Copyright 2018 Betamotor S.p.A.

# Tav.34B

Pos Loc Pos Ps Pos	Numero Number Numéro Número Nummer	Q.tà Q.ty Q.té M.ge C.ad	Nota Note Note Nota Anm.	Descrizione	Description	Désignation	Beschreibung	Descrìcion
								<b>SENIOR</b>
1	012.34.035.82.51	1		Forcella completa	Stirrup assy.	Fourchette compl.	Schaltgabel, Kompl.	Horquilla compl.
2	012.34.013.80.51	1		Gamba Dx.	R.H. leg	Tube D.	Beineinheit R.	Pata der.
3	012.34.014.80.51	1		Gamba Sx.	L.H. leg	Tube G.	Beineinheit L.	Pata izq.
4	007.34.926.00.00	1		Cartuccia idraulica forcella dx	R.H. Hydraulic fork spares	Cartouche hydraulique dr.	Hydraulischer Gabeldaempfer Rechts	Cartucho hidraulico horquilla der.
5	007.34.928.00.00	1		Gruppo pacco distensione	Extension pack assembly	Ensemble paquet extension	Baugruppe zugstufe	Conjunto paquete extensión
6	007.34.930.00.00	1		Gruppo pacco compressione	Compression pack assembly	Ensemble paquet compression	Baugruppe compressionpacket	Conjunto paquete compresión
7	007.34.931.00.00	1		Tappo destro	R.H. cap	Bouchon droite	Verschluß R.	Tapón derecho
8	007.34.948.00.00	1		Stelo Dx	RH slider	Montant D.	Bein R.	Deslizable derecho
9	007.34.024.40.51	1		Fodero DX	Sleeve R.H.	Protection Droit	Schutzstück Recht	Protección Der
10	007.34.936.00.00	1		Cartuccia idraulica forcella sx	L.H. Hydraulic fork spares	Cartouche hydraulique ga.	Hydraulischer Gabeldaempfer Links	Cartucho hidraulico horquilla izq.
11	007.34.949.00.00	1		Stelo Sx	L.H. slider	Montant G.	Bein L.	Deslizable izrda.
12	007.34.919.00.00	1		Tappo sinistro	L.H. cap	Bouchon gauge	Verschluß L.	Tapón izquierdo
13	012.34.006.00.00	1		Molla forcella	Fork spring	Ressort fourche	Gabelfeder	Muelle horquilla
14	007.34.023.40.51	1		Fodero SX	Sleeve L.H.	Protection Gauche	Schutzstück Linke	Protección Izq.
15	007.34.922.00.00	1		Kit viti	Kit screws	Jeu vis	Schraubensatz	Kit tornillos
16	007.34.923.00.00	1		Kit boccole	Bush kit	Kit douille	Buchsekit	Kit manguito
17	007.34.924.00.00	1		Kit guarnizioni	Packings kit	Jeu joints	Dichtungensatz	Grupo juntas
18	012.34.015.00.00	1		Kit distanziali	Spacers kit	Kit entretoises	Kit Distanzstück	kit distanciador
19	007.34.940.00.00	1		Gr. tamponamento idraulico	Hydraulic seals kit	Joints d'étanchéité	Hydraulischen Puffern	Kit de tampónes hidráulicos
20	31.63911.000	2		Vite TCCE M8.35	Screw TCCE M8.35	Vis TCCE M8.35	Schraube TCCE M8.35	Tornillo TCCE M8.35
21	007.34.055.82.59	2		Cavallotto manubrio - Kit	Handlebar u-bolt - Kit	Etrier guidon - Kit	Brücke Lenker - Kit	Brida manillar - Kit
23	007.34.005.00.00	1		Dado canotto	Head tube nut	Ecrou colonne	Lenkrohrmutter	Tuerca
24	007.34.320.82.59	1		Gruppo piastra sup. c/cavallotti	Steering head garup with u-bolts	Groupe tête de direction avec etriers	Satz Gabelkopf mit Brücke	Grup tija superior con bridas
25	10.66301.000	1		Anello OR 17.96.2,62	O-Ring 17.96.2,62	Bague d'étanchéité 17.96.2,62	O-Ring 17.96.2,62	Anillo OR 17.96.2,62
26	31.34510.000	7		Vite TCCE M6.20	Screw TCCE M6.20	Vis TCCE M6.20	Schraube TCCE M6.20	Tornillo TCCE M6.20
27	007.34.310.82.59	1		Piastra di sterzo inferiore	Steering crown with pin	Socle de direction avec pivot	Gabelbrücke mit Bolzen	Base de dirección con perno

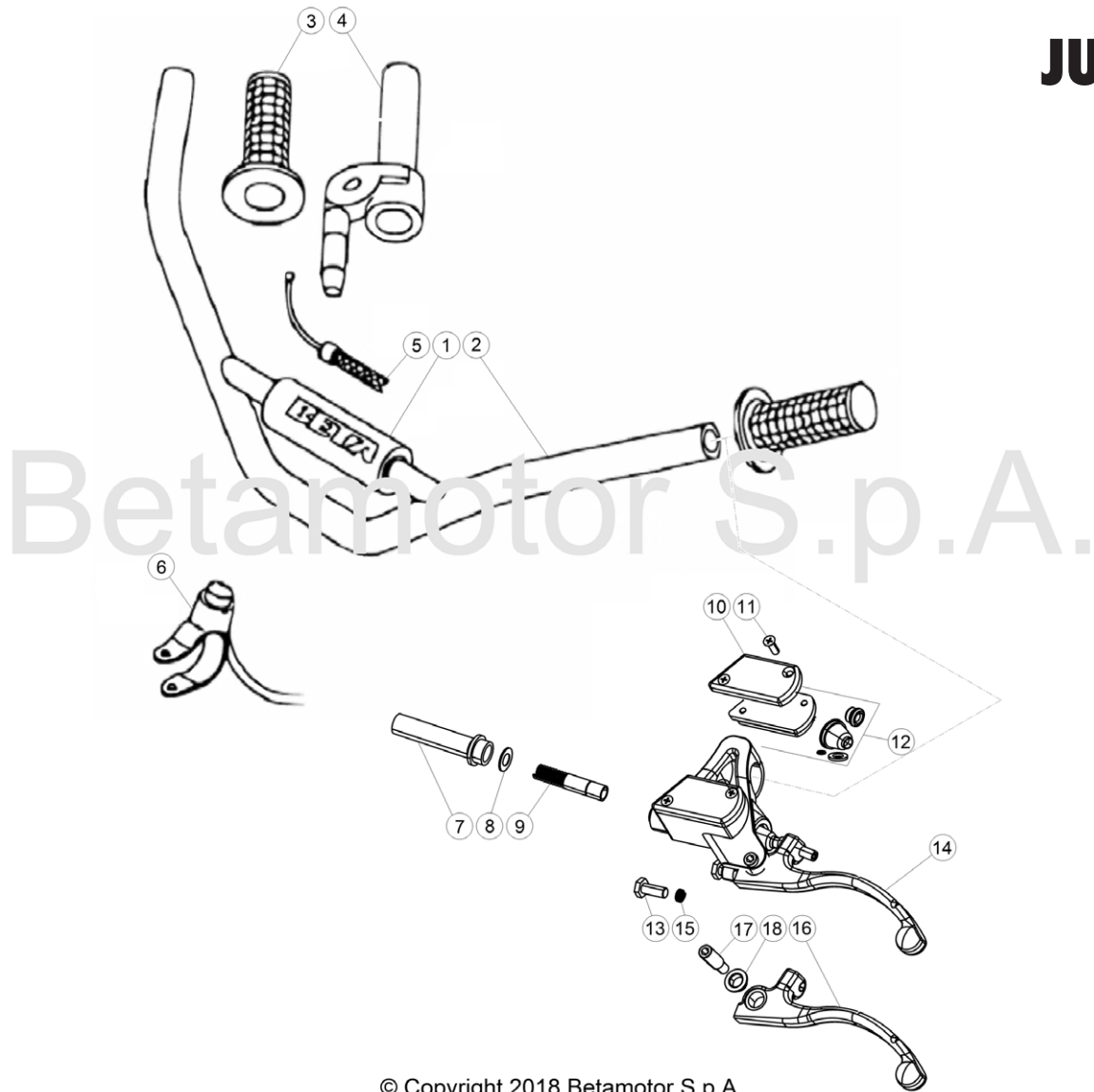

© Copyright 2018 Betamotor S.p.A.

Pos Loc Pos Ps Pos	Numero Number Numéro Número Nummer	Q.tà Q.ty Q.té M.ge C.ad	Nota Note Note Nota Anm.	Descrizione	Description	Désignation	Beschreibung	Descripció
1	16.23593.057	1		Protezione manubrio	Handlebar protection	Protection guidon	Lenkerschutz	Proteccion manillar
2	22.20454.026	1		Manubrio	Handlebars	Guidon	Lenker	Manillar
3	22.18531.000	1		Coppia manopole	Grips (couple)	Poignées (couple)	Handgriffpaar	Manecilla (juego)
4	12.55091.000	1		Comando gas	Throttle control	Comm. gaz	Gasdrehgriff	Mando gas
5	29.21977.052	1		Trasmissione gas	Throttle transmiss.	Transmission gaz	Gaszug	Transmisión gas
6	012.40.001.00.00	1		Interruttore massa	Ground switch	Interrupteur masse	Masseschalter	Interruptor masa
7	004.35.020.00.00	1		Tubo frizione	Clutch tube	Canalisation embrague	Kupplungsrohr	Tubo embrague
8	16.50510.000	1		Guarnizione 10x15x1 in rame	Gasket 10x15x1 copper	Joint 10x15x1 cuivre	Dichtung 10x15x1 Kupfer	Junta 10.15.1 (cobre)
9	20.05083.800	1		Kit pistoncino pompa ant.	Piston kit front master cyl.	Kit piston. maître cyl. AV.	Kolbensatz vorderhauptbremszylinder	Kit pistón bomba del.
10	12.68106.052	1		Coperchio serbatoio	Reservoir Lid	Couvercle De Réservoir	Behälterdeckel	Calderín Lid
11	31.23410.052	2		Vite fiss. tappo serbatoio freno anteriore	Front brake tank cap fastening screw	Vis de fixation bouchon réservoir frein avant	Befestigungsschraube Vorderbremse Öltankstöpsel	Tornillo fijación tapón deposito freno delantero
12	20.05074.000	1		Tappo completo	Complete cap	Bouchon complet	Verschluß komplett	Tapón completo
13	31.88601.000	1		Vite registro freno anteriore	Adjusting screw	Vis réglage	Einstellschrauben	Tornillo reg.
14	012.35.001.80.52	1		Leva frizione completa	Clutch lever, assy.	Levier d'embrayage complet	Kupplungshebel komplett	Palanca embrague completa
15	22.38701.000	1		Molla regolazione frizione	Clutch spring	Ressort réglage embrayage	Stellfeder	Muelle regulac. embrague
16	21.27084.000	1		Leva com.friz.nuda	Clutch lever only	Levier complet embrayage nue	Kupplungshebel	Palanca embrague
17	31.96818.000	1		Vite speciale	Special screw	Vis spéciale	Spezialschraube	Tornillo especial
18	11.26465.000	1		Boccola	Bush	Moyeu	Büchse	Buje

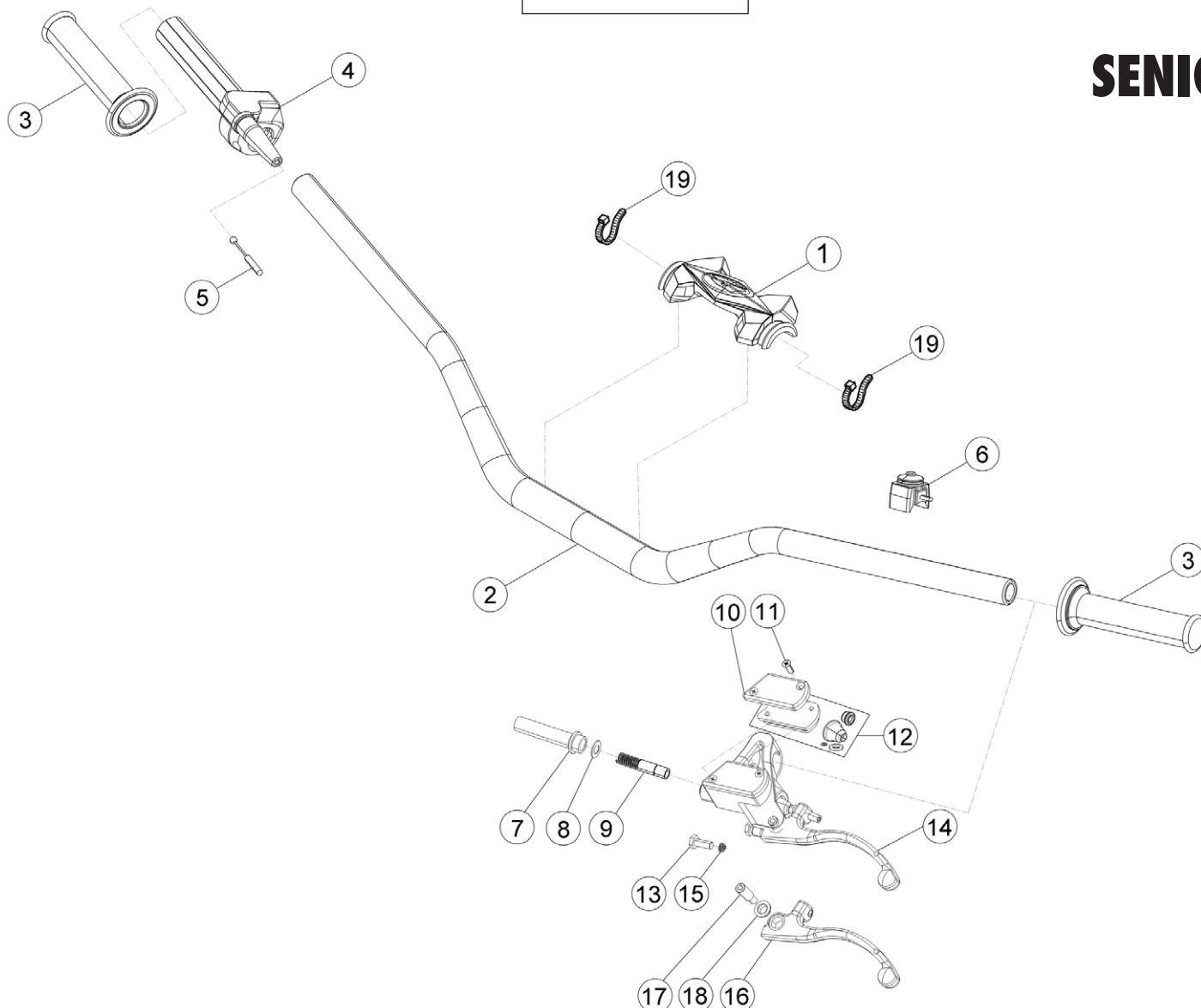

Pos	Numero	Q.tà	Nota	Descrizione	Description	Désignation	Beschreibung	Descripcìon
Loc	Number	Q.ty	Note					
Pos	Numéro	Q.té	Note					
Ps	Número	M.ge	Nota					
Pos	Nummer	C.ad	Anm.					
1	007.35.066.00.00	1		Protezione manubrio	Handlebar protection	Protection du guidon	Lenkerschutz	Protección del manillar
2	032.35.002.00.59	1		Manubrio	Handlebar	Guidon	Lenker	Manillar
3	22.18531.000	1		Coppia manopole	Grips (couple)	Poignées (couple)	Handgriffpaar	Manecilla (juego)
4	12.55091.000	1		Comando gas	Throttle control	Comm. gaz	Gasdrehgriff	Mando gas
5	29.21977.052	1		Trasmissione gas	Throttle transmiss.	Transmission gaz	Gaszug	Transmisión gas
6	012.40.001.00.00	1		Interruttore massa	Ground switch	Interrupteur masse	Masseschalter	Interruptor masa
7	004.35.020.00.00	1		Tubo frizione	Clutch tube	Canalisation embrague	Kupplungsrohr	Tubo embrague
8	16.50510.000	1		Guarnizione 10x15x1 in rame	Gasket 10x15x1 copper	Joint 10x15x1 cuivre	Dichtung 10x15x1 Kupfer	Junta 10.15.1 (cobre)
9	20.05083.800	1		Kit pistoncino pompa ant.	Piston kit front master cyl.	Kit piston. maître cyl. AV.	Kolbensatz vorderhauptbremszylinder	Kit pistón bomba del.
10	12.68106.052	1		Coperchio serbatoio	Reservoir Lid	Couvercle De Réservoir	Behälterdeckel	Calderín Lid
11	31.23410.052	2		Vite fiss. tappo serbatoio freno anteriore	Front brake tank cap fastening screw	Vis de fixation bouchon réservoir frein avant	Befestigungsschraube Vorderbremse Öltankstöpsel	Tornillo fijación tapón deposito freno delantero
12	20.05074.000	1		Tappo completo	Complete cap	Bouchon complet	Verschluß komplett	Tapón completo
13	31.88601.000	1		Vite registro freno anteriore	Adjusting screw	Vis réglage	Einstellschrauben	Tornillo reg.
14	012.35.001.80.52	1		Leva frizione completa	Clutch lever, assy.	Levier d'embrayage complet	Kupplungshebel komplett	Palanca embrague completa
15	22.38701.000	1		Molla regolazione frizione	Clutch spring	Ressort réglage embrayage	Stellfeder	Muelle regulac. embrague
16	21.27084.000	1		Leva com.friz.nuda	Clutch lever only	Levier complet embrayage nue	Kupplungshebel	Palanca embrague
17	31.96818.000	1		Vite speciale	Special screw	Vis spéciale	Spezialschraube	Tornillo especial
18	11.26465.000	1		Boccola	Bush	Moyeu	Büchse	Buje
19	15.13020.000	2		Fascetta di nylon	Cable tie	Collier	Kabel-Schelle	Abrazadera

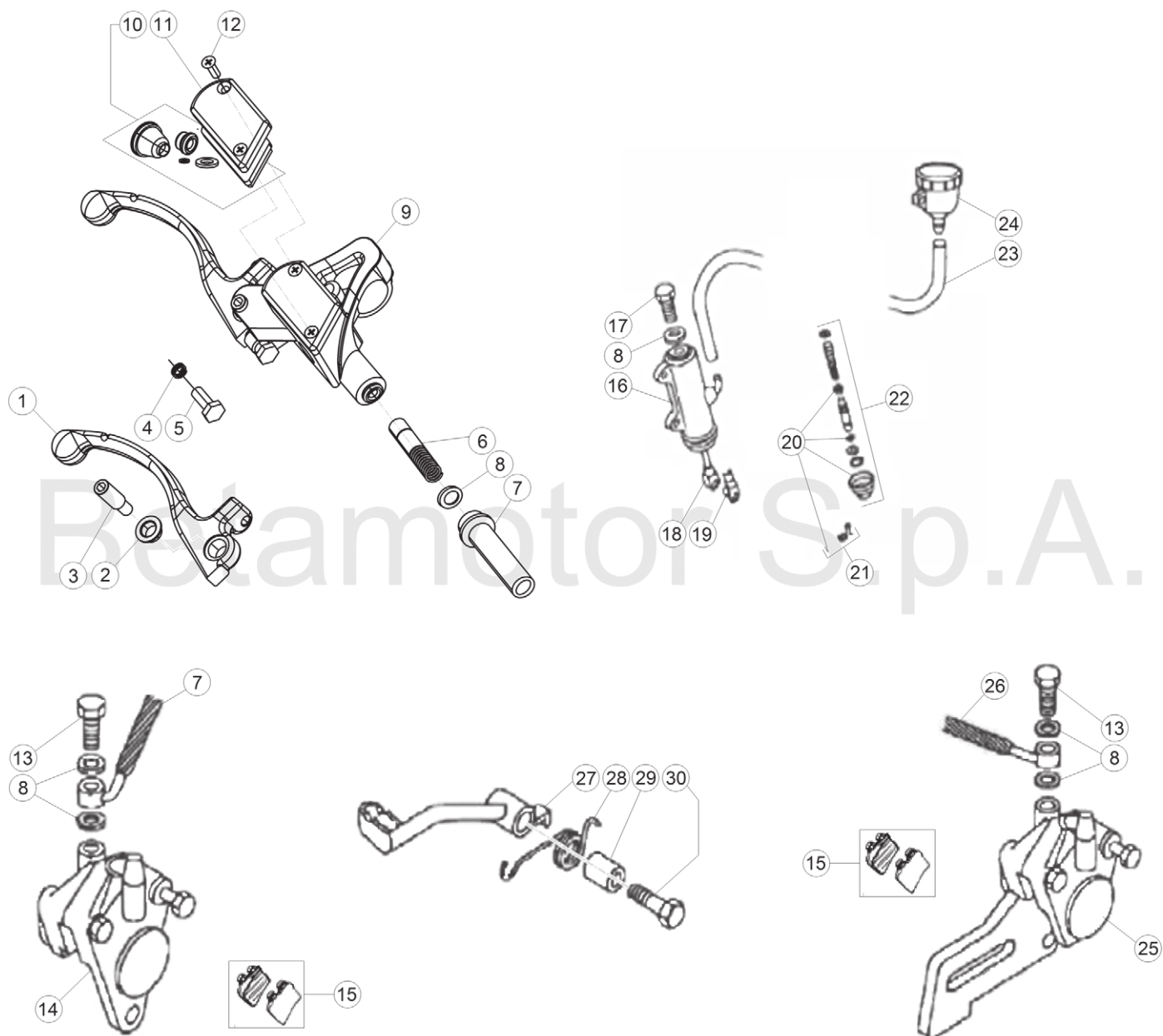

© Copyright 2018 Betamotor S.p.A.

Pos Loc Pos Ps Pos	Numero Number Numéro Número Nummer	Q.tà Q.ty Q.té M.ge C.ad	Nota Note Note Nota Anm.	Descrizione	Description	Désignation	Beschreibung	Descrìcion
								<b>JUNIOR</b>
1	21.27103.000	1		Leva freno ant. nuda	Fr. brake lever	Levier frein AV.	Vorderradbremshebel	Palanca freno del.
2	11.26465.000	1		Boccola speciale leva	Bush	Moyeu	Büchse	Buje
3	31.96818.000	1		Vite speciale leva freno	Special screw	Vis spéciale	Spezialschraube	Tornillo especial
4	22.38701.000	1		Molla regolazione freno	Brake adjusting spring	Ressort réglage frein	Stellfeder Vorderbrem	Muelle regulac. freno
5	31.88601.000	1		Vite registro freno anteriore	Adjusting screw	Vis réglage	Einstellschrauben	Tornillo reg.
6	20.05083.800	1		Kit pistoncino pompa ant.	Piston kit front master cyl.	Kit piston. maître cyl. AV.	Kolbensatz vorderhauptbremszylinder	Kit pistón bomba del.
7	29.09118.000	1		Tubo freno ant.	Front brake tube	Tuyau du frein AV.	Vordere Bremsleitung	Tubo freno delantero
8	16.50510.000	6		Guarnizione 10x15x1 in rame	Gasket 10x15x1 copper	Joint 10x15x1 cuivre	Dichtung 10x15x1 Kupfer	Junta 10.15.1 (cobre)
9	012.36.003.80.52	1		Pompa freno anteriore	Fr. brake master cylinder	Mâitre cylindre fr. AV.	Hauptbremszylinder Vorderradbremse	Bomba fr. del.
10	20.05075.000	1		Tappo completo	Complete cap	Bouchon complet	Verschluß komplett	Tapón completo
11	12.68107.052	1		Coperchio pompa olio	Oil pump cover	Couvercle pompe huile	Ölpumpendeckel	Tapa bomba aceite
12	31.23410.052	2		Vite fiss. tappo serbatoio freno anteriore	Front brake tank cap fastening screw	Vis de fixation bouchon réservoir frein avant	Befestigungsschraube Vorderbremse Öltankstöpsel	Tornillo fijación tapón deposito freno delantero
13	11.65041.000	4		Bullone forato	Special bolt	Boulon tube frein	Hohlschraube F.Bremse	Perno banjo
14	25.03047.000	1		Pinza freno anteriore	Front disk brake caliper	Etrier de frein AV.	Bremsszange-Scheibe	Pinza freno del.
15	25.25241.000	2		Pastiglie freno	Brake pads	Plaquettes pince	Bremsbeläge hinten	Pastillas pinza
16	25.91188.000	1		Pompa freno post.	Rear brake master cyl.	Mâitre cylindre fr. AR.	Hauptbremszylinder	Bomba fr. tras.
17	11.65040.000	1		Bullone forato 10x1	Special bolt 10x1	Boulon 10x1	Hohlschraube F.Bremse 10x1	Perno banjo 10.1
18	10.84091.000	1		Asta com.pompa freno post	Rear brake rod	Tige de commande pompe frein	Betaetigungsstange Bremse hi.	Varilla bomba freno post.
19	28.93130.000	1		Staffa	Bracket	Support	Halterung	Soporte
20	20.08262.000	1		Kit ricambi pompa	Kit pump (spare parts)	Jeu pieces pompe	Reparatursatz Pumpe	Juego piezas bomba
21	27.23424.000	1		Raccordo 90°	Joint p. 90°	Raccord 90°	Stutzen 90°	Racor 90°
22	20.08257.000	1		Kit pistoncino pompa post.	Piston kit rear master cyl.	Kit piston. maître cyl. ar.	Kolbensatz hauptbremszylinder	Kit pistón bomba tras.
23	012.36.000.14.00	1		Tubo olio	Oil tube	Tuyau huile	Schlauch	Tubo aceite
24	28.05100.000	1		Serbatoio olio freni	Brake oil tank	Réservoir huile frein	Bremsflüssigkeitstank	Depósito aceite frenos
25	25.03033.000	1		Pinza freno post.	Rear disk brake caliper	Etrier de frein AR.	Bremsszange	Pinza del freno tras.
26	29.09134.000	1		Tubo freno posteriore	Rear brake tube	Tuyau du frein AR.	Hintere Bremsleitung	Tubo freno trasero
27	25.28096.000	1		Pedale freno	Brake pedal	Pédale frein	Fussbremspedal	Pedal freno
28	22.80510.000	1		Molla ritorno pedale freno	Return brake pedal spring	Ressort de retour frein	Bremspedal Feder	Muelle retorno palanca freno
29	11.31031.000	1		Boccola sinterizzata 14x18x155	Bush 14x18x155	Bague 14x18x155	Sinterbuchse 14x18x155	Casquillo 14x18x155
30	11.55450.000	1		Bullone M8x40	Bolt M8x40	Boulon M8x40	Bolzen M8x40	Tornillo M8x40

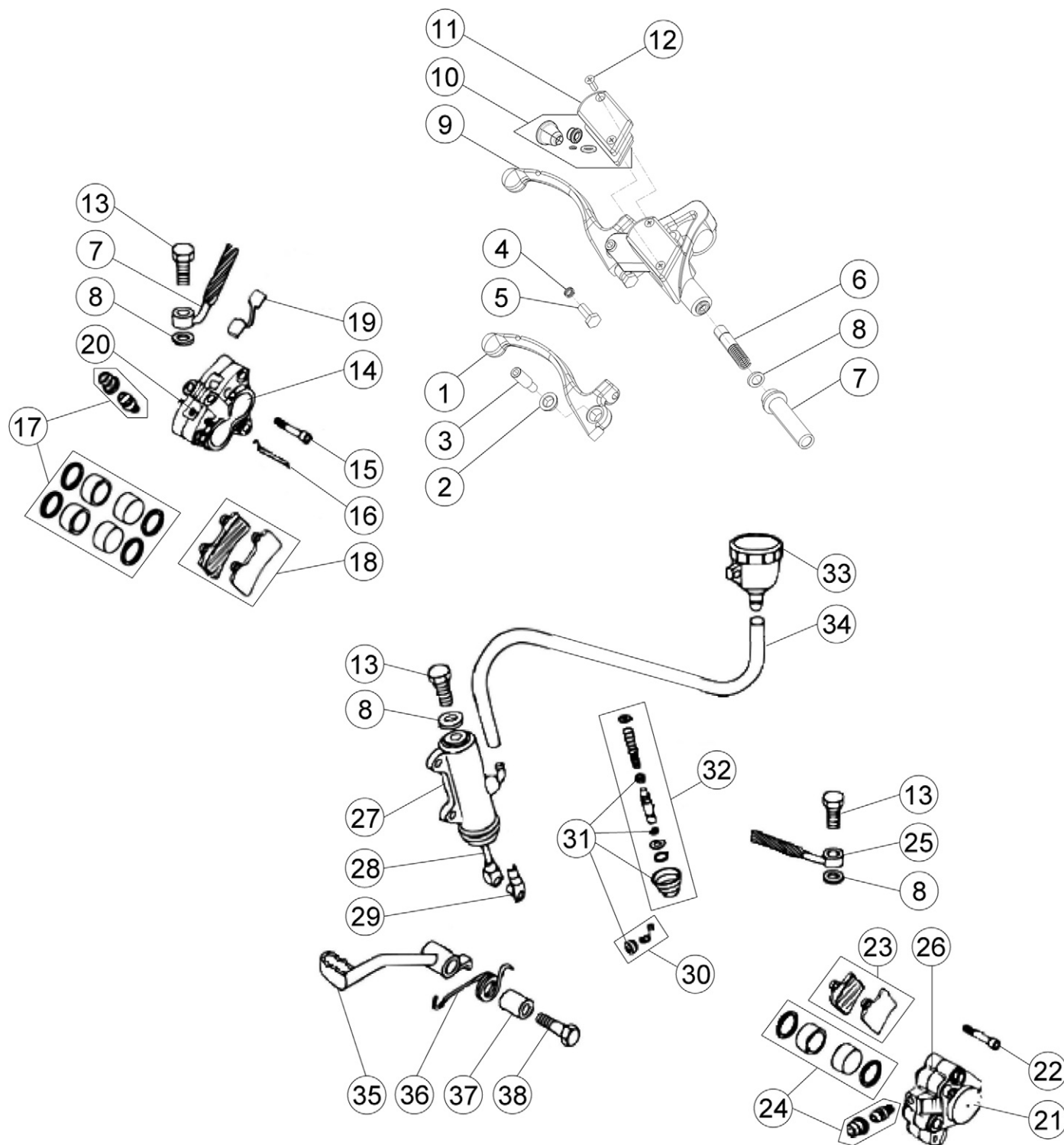



Pos Loc Pos Ps Pos	Numero Number Numéro Número Nummer	Q.tà Q.ty Q.té M.ge C.ad	Nota Note Note Nota Anm.	Descrizione	Description	Désignation	Beschreibung	Descrìcion
								<b>SENIOR</b>
1	21.27103.000	1		Leva freno ant.	Fr. br. lever	Lev. fr. AV.	Vorderradbremshebel	Pal. fr. del.
2	11.26465.000	1		Boccola	Bush	Moyeu	Büchse	Buje
3	31.96818.000	1		Vite speciale	Special screw	Vis spéciale	Spezialschraube	Tornillo especial
4	22.38701.000	1		Molla regolazione freno	Brake adjusting spring	Ressort réglage frein	Stellfeder Vorderbrem	Muelle regulac. freno
5	31.88601.000	1		Vite registro freno anteriore	Adjusting screw	Vis réglage	Einstellschrauben	Tornillo reg.
6	20.05083.800	1		Kit pistoncino pompa ant.	Piston kit front master cyl.	Kit piston. maître cyl. AV.	Kolbensatz vorderhauptbremszylinder	Kit pistón bomba del.
7	29.09123.000	1		Tubo freno ant.	Front brake tube	Tuyau du frein AV.	Vordere Bremsleitung	Tubo freno delantero
8	16.50510.000	8		Guarnizione 10x15x1 in rame	Gasket 10x15x1 copper	Joint 10x15x1 cuivre	Dichtung 10x15x1 Kupfer	Junta 10.15.1 (cobre)
9	012.36.003.80.52	1		Pompa freno anteriore	Fr. brake master cylinder	Mâitre cylindre fr. AV.	Hauptbremszylinder Vorderradbremse	Bomba fr. del.
10	20.05075.000	1		Tappo completo	Complete cap	Bouchon complet	Verschluß komplett	Tapón completo
11	12.68107.052	1		Coperchio pompa olio	Oil pump cover	Couvercle pompe huile	Ölpumpendeckel	Tapa bomba aceite
12	31.23410.052	2		Vite fiss. tappo serbatoio freno anteriore	Front brake tank cap fastening screw	Vis de fixation bouchon réservoir frein avant	Befestigungsschraube Vorderbremse Öltankstöpsel	Tornillo fijación tapón deposito freno delantero
13	11.65040.000	3		Bullone forato 10x1 x tubo freno	Special bolt	Boulon 10x1 x tube frein	Hohlschraube F.Bremse	Perno banjo10.1
14	032.36.001.80.59	1		Pinza freno anteriore	Front disk brake caliper	Etrier de frein AV.	Bremsschlinge-Scheibe	Pinza freno del.
15	11.70521.000	1		Bullone fiss. Pastiglie	Brake pads fastening bolt	Boulon de fixation jeu past. fr.	Befestigungsbolzen Bremzange	Tornillo fijación Juego past. Frenos
16	22.32206.000	1		Molla ferma pastiglie pinza	Brake pads spring for pliers	Ressort arret plaquettes	Haltefeder	Muelle pastillas pinza
17	20.02714.000	1		Kit pistoncini e guarniz. Pinza	Piston e oil seal for pliers	Jeu petit pistons et joint pince	Reparatursatz Bremszange	Juego piston y guarnicion pinza
18	25.25352.000	1		Pastiglie per pinza	Brake pads	Plaquettes pince	Bremsbeläge hinten	Pastillas pinza
19	25.98915.000	1		Protezione pastiglie freno	Brake pads cover	Protection jeu past. fr.	Bremzangenschutz	Protección Juego past. Frenos
20	31.96801.000	1		Vite spurgo pinza	Special screw	Vis pour pince	Spezial schraube	Tornillo aliento pinza
21	032.36.055.00.59	1		Pinza freno posteriore	Rear disk brake caliper	Etrier de frein AR.	Bremsschlinge	Pinza del freno tras.
22	11.70520.000	1		Bullone fiss. Pastiglie	Brake pads fastening bolt	Boulon de fixation jeu past. fr.	Befestigungsbolzen Bremzange	Tornillo fijación Juego past. Frenos
23	25.25373.000	1		Pastiglie freno post.	Rear brake pads	Pastill. de freins AR.	Hinterbremsbelag	Pastillas frenos tras.
24	20.02722.000	1		Kit pistoncini e guarniz. Pinza	Piston e oil seal for pliers	Jeu petit pistons et joint pince	Reparatursatz Bremszange	Juego piston y guarnicion pinza
25	29.09135.000	1		Tubo freno posteriore	Rear brake tube	Tuyau du frein AR.	Hintere Bremsleitung	Tubo freno trasero
26	31.96825.000	1		Vite spurgo	Screw	Vis	Schraube	Tornillo
27	25.91188.000	1		Pompa freno post.	Rear brake master cyl.	Mâitre cylindre fr. AR.	Hauptbremszylinder Hinterradbremse	Bomba fr. tras.
28	10.84091.000	1		Asta com.pompa freno post	Rear brake rod	Tige de commande pompe frein	Betaetigungsstange Bremse hi.	Varilla bomba freno post.
29	28.93130.000	1		Staffa	Bracket	Support	Halterung	Soporte
30	27.23424.000	1		Raccordo 90°	Joint p. 90°	Raccord 90°	Stutzen 90°	Racor 90°
31	20.08262.000	1		Kit ricambi pompa	Kit pump (spare parts)	Jeu pieces pompe	Reparatursatz Pumpe	Juego piezas bomba
32	20.08257.000	1		Kit pistoncino pompa post.	Piston kit rear master cyl.	Kit piston. maître cyl. AR.	Kolbensatz hinterhauptbremszylinder	Kit pistón bomba tras.
33	28.05100.000	1		Serbatoio olio freni	Brake oil tank	Réservoir huile frein	Bremsflüssigkeitstank	Depósito aceite frenos
34	012.36.000.14.00	1		Tubo olio	Oil tube	Tuyau huile	Schlauch	Tubo aceite
35	25.28096.000	1		Pedale freno	Brake pedal	Pédale frein	Fussbremspedal	Pedal freno
36	22.80510.000	1		Molla ritorno pedale freno	Return brake pedal spring	Ressort de retour frein	Bremspedal Feder	Muelle retorno palanca freno
37	11.31031.000	1		Boccola sinterizzata 14x18x155	Bush 14x18x155	Bague 14x18x155	Sinterbuchse 14x18x155	Casquillo 14x18x155
38	11.55450.000	1		Bullone M8x40	Bolt M8x40	Boulon M8x40	Bolzen M8x40	Tornillo M8x40

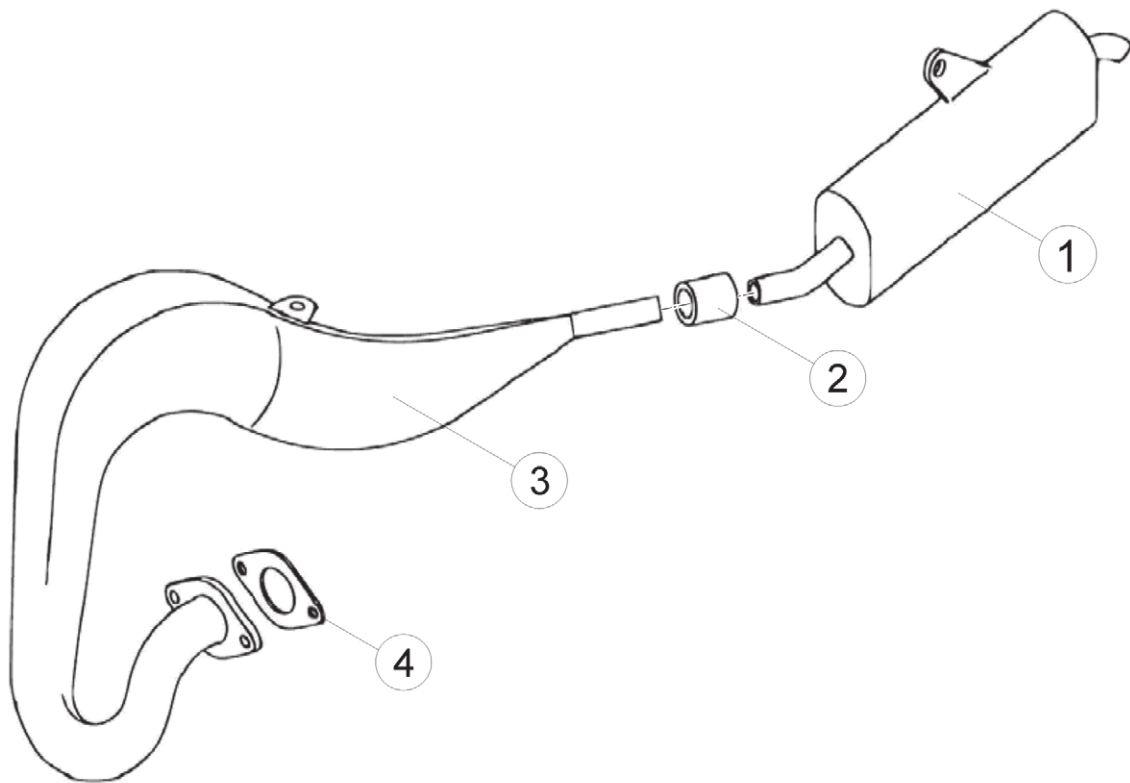

Pos Loc Pos Ps Pos	Numero Number Numéro Número Nummer	Q.tà Q.ty Q.té M.ge C.ad	Nota Note Note Nota Anm.	Descrizione	Description	Désignation	Beschreibung	Descripción
1	28.91790.000	1		Silenziatore	Silencer	Silencieux	Schalldämpfer	Silenciador
2	22.12120.000	1		Manicotto gomma	Boot	Manchon caoutchouc	Gummimanschette	Manguito de goma
3	22.03344.000	1		Marmitta	Silencer	Silencieux	Auspufftopf	Silenciador
4	16.80321.000	1	Senior	Guarnizione scarico	Exhaust manifold gasket	Joint coll. Ech.	Dichtung Abgaskrümmer	Junta colector de escape
4	16.80323.000	1	Junior	Guarnizione scarico	Exhaust manifold gasket	Joint coll. Ech.	Dichtung Abgaskrümmer	Junta colector de escape

# Tav.38

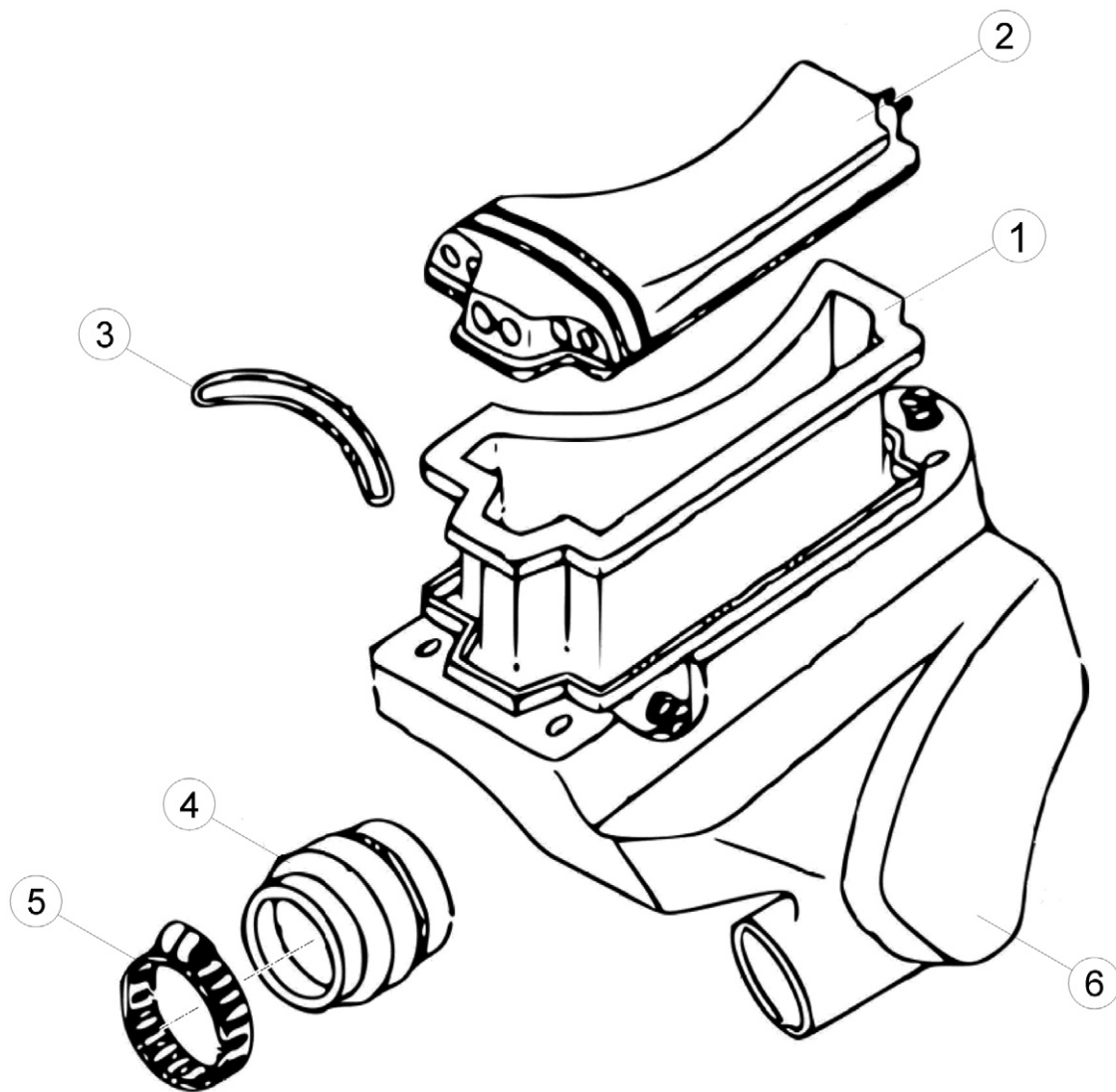

Pos Loc Pos Ps Pos	Numero Number Numéro Número Nummer	Q.tà Q.ty Q.té M.ge C.ad	Nota Note Note Nota Anm.	Descrizione	Description	Désignation	Beschreibung	Descripcìon
1	15.25205.000	1		Filtro in spugna	Air filter	Filtre en eponge	Luftfilter	Espuma filtro
2	12.73181.000	1		Coperchio scatola filtro	Filter case cover	Couvercle boîte filtre	Filtergehäusedeckel	Tapa caja filtro
3	14.40040.000	1		Elastico fissaggio	Elastic rubber	Elastique de fixage	Befestigungsband	Elastico
4	22.13576.000	1		Manicotto scatola filtro	Filter box sleeve	Manchon boîte du filtre	Filtergehäuseemuffe	Manguito caja filtro
5	15.15360.000	1		Fascetta 25/45	Clamp 25/45	Collier 25/45	Schelle 25/45	Abrazadera 25/45
6	28.12693.000	1		Scatola filtro	Filter box	Boîtier du filtre	Luftfiltergehäuse	Caja del filtro

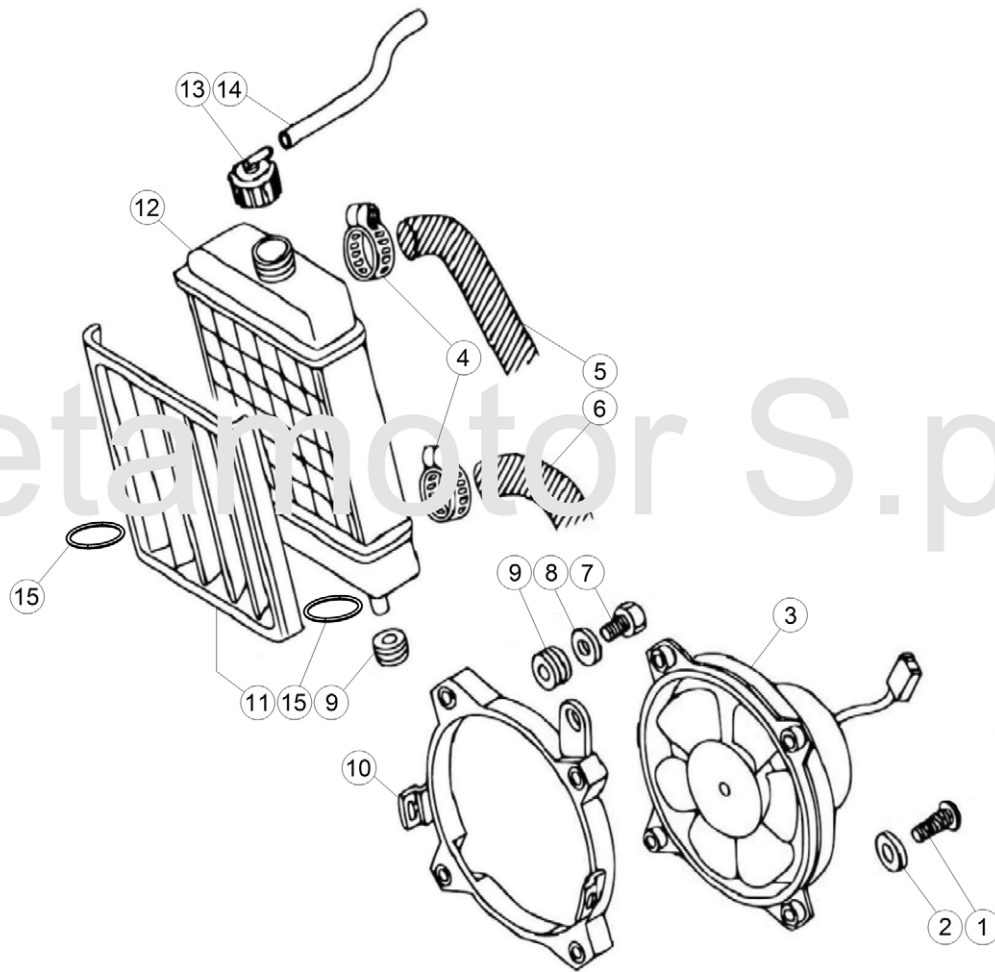

© Copyright 2019 Betamotor S.p.A.

Pos Loc Pos Ps Pos	Numero Number Numéro Número Nummer	Q.tà Q.ty Q.té M.ge C.ad	Nota Note Note Nota Anm.	Descrizione	Description	Désignation	Beschreibung	Descripción
1	31.27510.000	4		Vite tcic 4.20	Screw tcic 4.20	Vis tcic 4.20	Schraube tcic 4.20	Tornillo tcic 4.20
2	27.34650.000	4		Rondella 4.9	Washer 4.9	Rondelle 4.9	Scheibe 4.9	Arandela 4.9
3	14.01040.000	1		Elettroventola	Electric fan	Electro-ventilateur	Elektrolüfterrad	Electroventilador
4	15.15230.000	2		Fascetta 15x25	Clamp 15x25	Collier 15x25	Schelle 15x25	Abrazadera 15x25
5	29.15736.000	1		Tubo radiatore sup.	Upper radiator hose	Tuyau radiateur sup.	Kühlerschlauch oben	Tubo radiador sup.
6	29.15735.000	1		Tubo radiatore inf.	Lower radiator hose	Tuyau radiateur inf.	Kühlerschlauch unten	Tubo radiador inf.
7	11.46100.000	1		Bullone 5.8 CH 8	Bolt 5.8 CH 8	Boulon 5.8 CH 8	Bolzen 5.8 CH 8	Tornillo 5.8 CH 8
8	27.36500.000	1		Rondella 5x15	Washer 5x15	Rondelle 5x15	U.Scheibe 5x15	Arandela 5x15
9	28.91500.000	2		Silent-block	Silentbloc	Silent block	Puffer	Silent block
10	28.98012.059	1		Supporto elettroventola	Heater fan support	Support ventilateur	Halterung Kühlgebläse	Soporte electroventilador
11	16.45538.159	1		Griglia radiatore	Radiator grille	Calandre	Kühlgrill	Reja del radiador
12	27.23642.000	1		Radiatore	Cooler	Radiateur	Kühler	Radiador
13	29.01821.000	1		Tappo radiatore REV3	Radiator plug REV3	Bouchon radiateur REV3	Kühlerdeckel REV3	Tapa de radiador REV3
14	012.39.000.14.00	1		Tubo sfiato	Breather tube	Tuyau réinflard	Entlüftungsleitung	Tubo respiradero
15	C02.06.022.00.00	2		Anello OR 28,25x33,49x2,62	O-Ring 28,25x33,49x2,62	Bague d'étanchéité 28,25x33,49x2,62	O-Ring 28,25x33,49x2,62	Anillo OR 28,25x33,49x2,62

## GR. COMPONENTI ELETTRICI/CABLAGGI

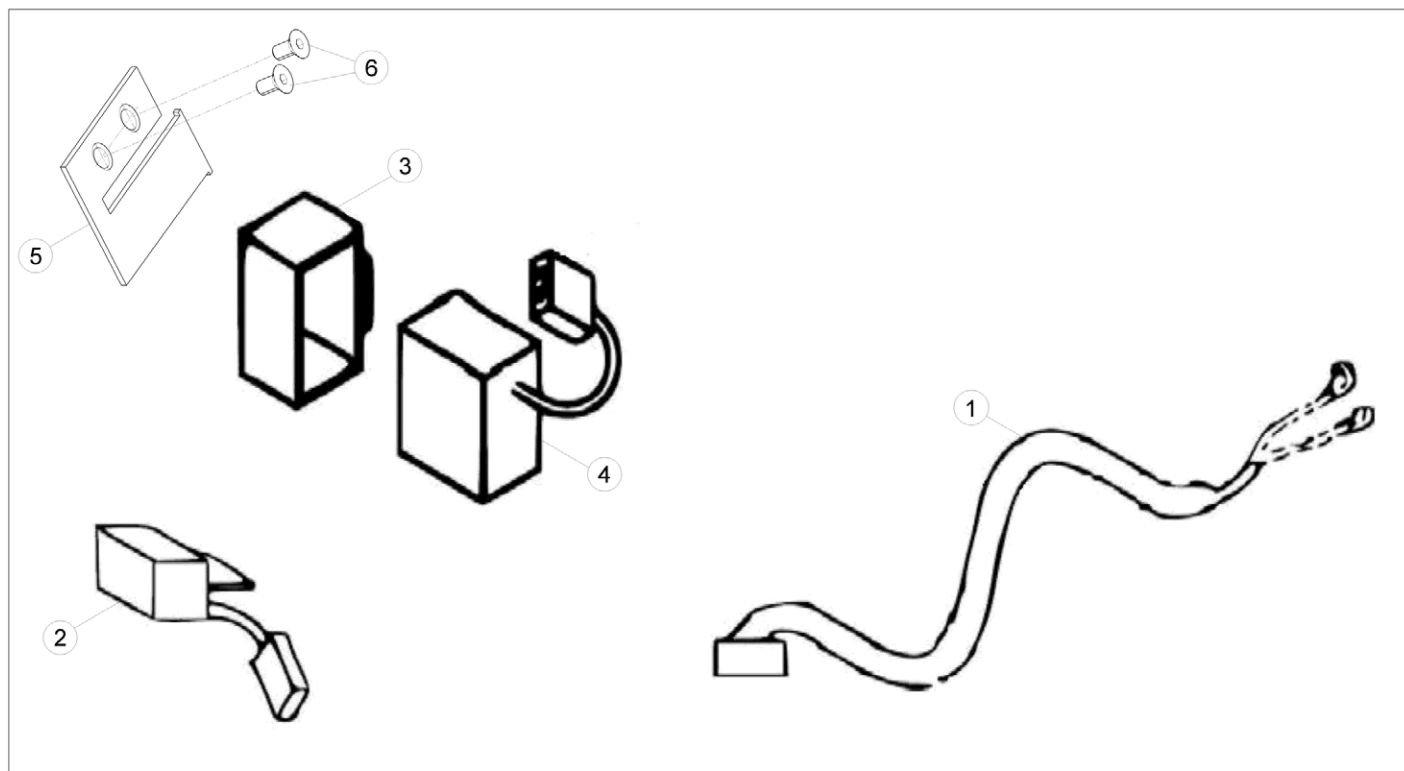

## GR. ACCESSORI

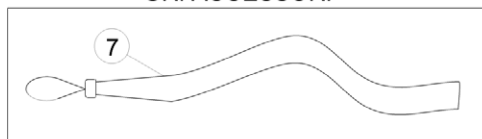

Pos Loc Pos Ps Pos	Numero Number Número Nummer	Q.tà Q.ty Q.té M.ge C.ad	Nota Note Note Nota Anm.	Descrizione	Description	Désignation	Beschreibung	Descripcìon
1	18.01851.000	1		Impianto termointerruttore	Electric equipment	Installation interrupt.termique	Kabelbaum	Instalación termointerruptor
2	27.28092.000	1		Regolatore	Regulator	Régulateur	Regler	Regulador
3	16.23325.000	1		Supporto in gomma centralina	Rubber bracket, CDI UNIT	Support en caoutchouc CDI	Gummihalter f. Steuergehäuse	Soporte en goma
4	12.41831.000	1		Centralina digitale	CDI unit	Bobine digital (C.D.I.)	Steuergerät	Centralita digital
5	28.95334.000	1		Staffa supporto centralina	ECU unit support bracket	Bride support centrale élect.	Befestigung Steuergerät	Brida soporte centralita
6	31.30500.000	2		Vite TSPCE M6.12	Screw TSPCE M6.12	Vis TSPCE M6.12	Schraube TSPCE M6.12	Tornillo TSPCE M6.12
7	007.40.036.00.00	1		Cordino spegnimento motore di sicurezza	Kill switch with wrist lanyard	Cordon arret moteur de sécurité	Kurzschlusschalter mit Reissleine	Kit de seguridad apagado motor

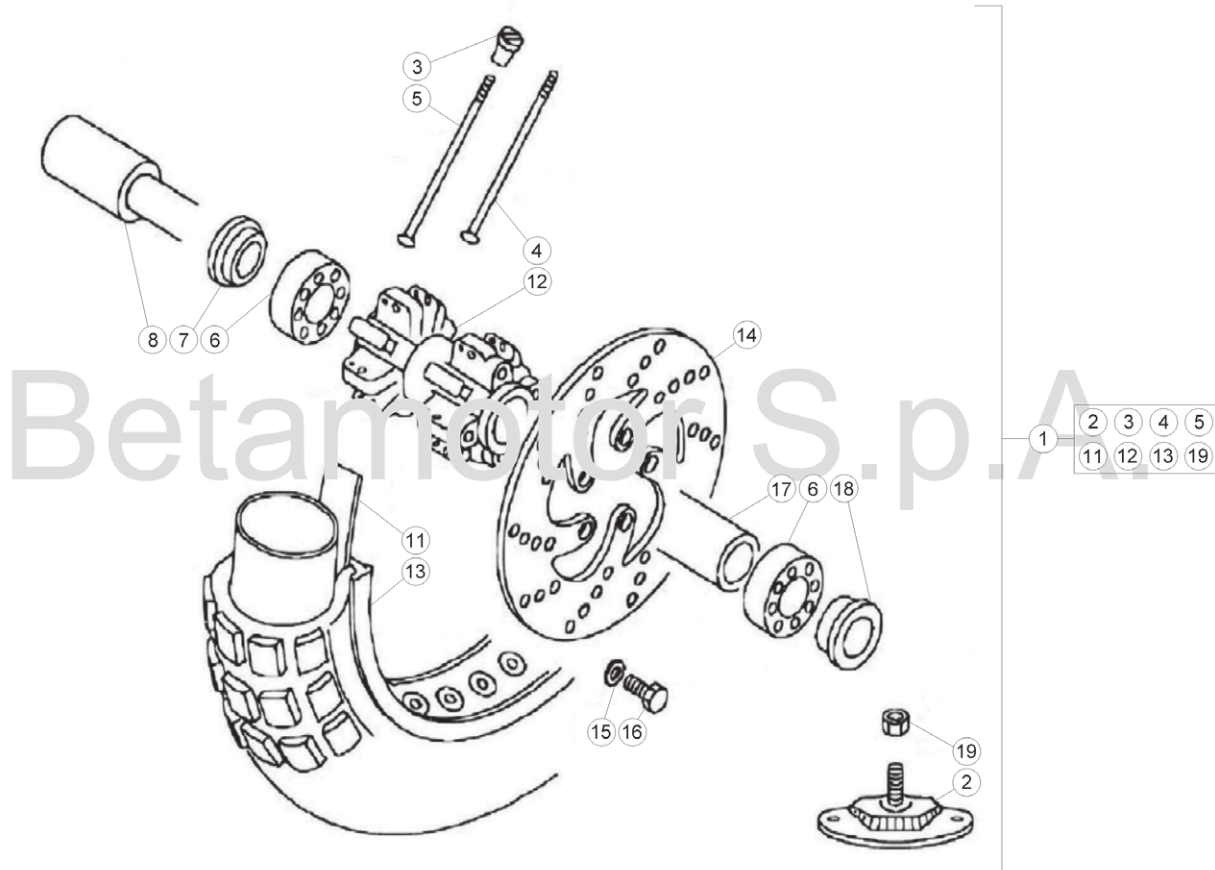

© Copyright 2016 Betamotor S.p.A.

Pos Loc Pos Ps Pos	Numero Number Numéro Número Nummer	Q.tà Q.ty Q.té M.ge C.ad	Nota Note Note Nota Anm.	Descrizione	Description	Désignation	Beschreibung	Descripción
1	012.41.018.00.00	1		Ruota anteriore premontata	Rear wheel assy.	Roue avant p/motée	Vormontiertes vorderrad	Rueda delantera montada
2	15.17500.000	1		Fermafascioni	Tire fastener	Caoutchouc serrure chambre	Reifen Halter	Agarre cubierta ant.
3	23.10060.000	36		Nipplo	Nipple	Ecrou	Nippel	Tuerca
4	27.23830.000	18		Raggio lato disco 3.224 c.169	Spoke 3.224 c.169	Bras 3.224 c.169	Speiche 3.224 c.169	Radio 3.224 c.169
5	27.23832.000	18		Raggio destro 3.226 c.169	Spoke R. 3.226 c.169	Bras D. 3.226 c.169	Speiche R. 3.226 c.169	Radio der. 3.226 c.169
6	12.94010.000	2		Cuscinetto	Bearing	Roulement	Lager	Cojinete
7	13.85766.000	1		Distanziale dx.	R.H. spacer	Entretoise droite	Rechtes Distanzstück	Distanciad. Der.
8	25.55693.000	1		Perno ruota anteriore	Front wheel spindle	Pivot roue AV.	Vorderradzapfen	Perno ruota delantera
11	15.36011.000	1		Flap	Bead	Flap	Felgenband	Cinta tapa radios "flap"
12	22.07243.059	1		Mozzo anteriore	Front hub	Moyeu avant	Vorderer Nabe	Buje delantero
13	12.42863.003	1		Cerchio anteriore 1,40-19-1-00 anod.	Front rim 1,40-19-1-00 anod.	Jante avant 1,40-19-1-00 anod.	Vorderfelge 1,40-19-1-00 anod.	Llanta delantera 1,40-19-1-00 anod.
14	13.39276.000	1		Disco freno ant.	Front brake disk	Disque frein avant	Vorderbremscheibe	Disco freno delantero
15	27.40470.000	5		Rondella 6,4.10.0,7	Washer 6,4.10.0,7	Rondelle 6,4.10.0,7	U.Scheibe 6,4.10.0,7	Arandela 6,4.10.0,7
16	11.49010.000	5		Bullone M6x20 TE	Bolt M6x20 TE	Boulon M6x20 TE	Bolzen M6x20 TE	Tornillo M6x20 TE
17	13.62704.000	1		Distanziale interno	Inner spacer	Entretoise interne	Inneres Distanzstück	Distanciad. interior
18	13.85765.000	1		Distanziale Sx.	L.H. spacer	Entretoise gauche	Linkes Distanzstück	Distanciad. Izq.
19	13.17120.000	1		Dado flangiato M8	Flanged nut M8	Ecrou bordé M8	Flanschmutter M8	Tuerca embreada M8

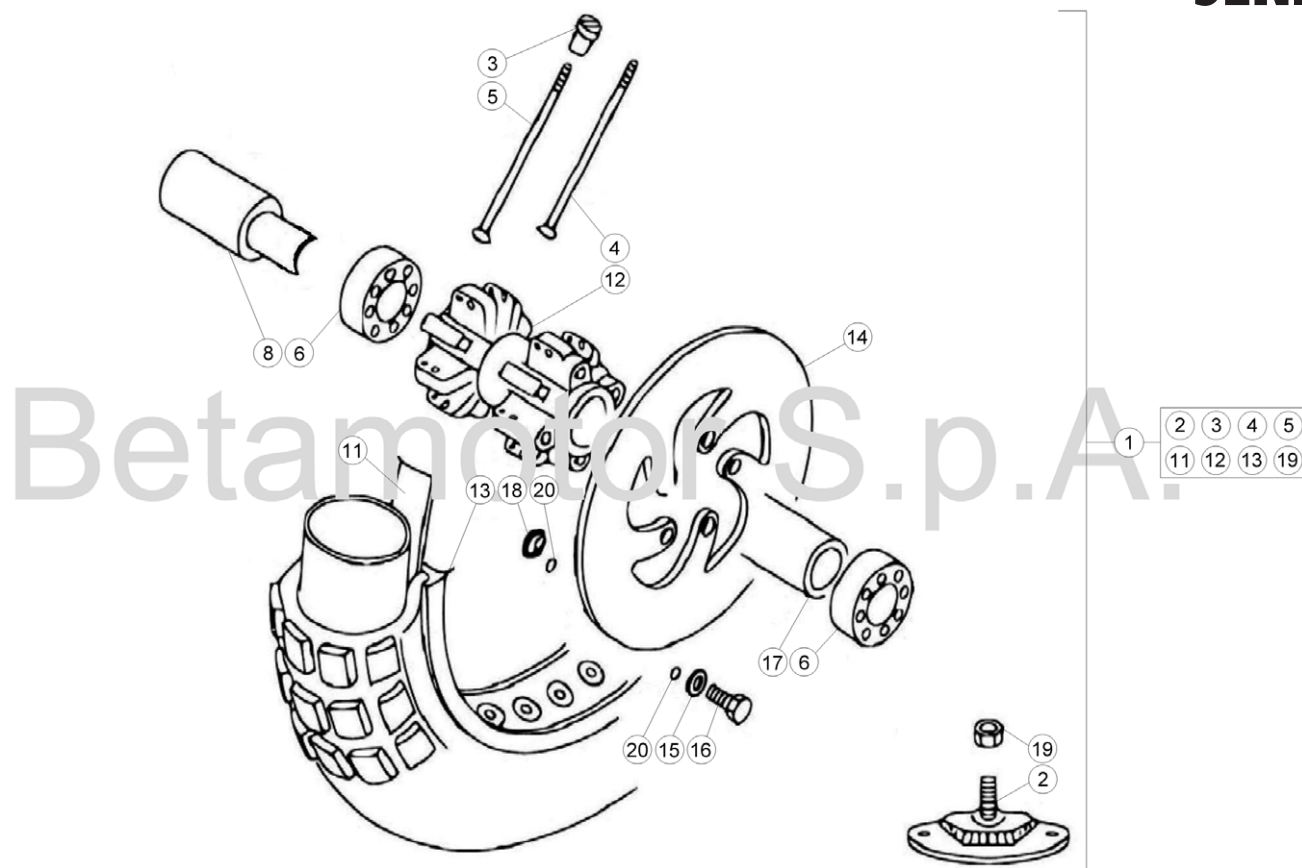

© Copyright 2016 Betamotor S.p.A.

Pos Loc Pos Ps Pos	Numero Number Numéro Número Nummer	Q.tà Q.ty Q.té M.ge C.ad	Nota Note Note Nota Anm.	Descrizione	Description	Désignation	Beschreibung	Descripcìon
1	012.41.021.00.00	1		Ruota anteriore premontata	Rear wheel assy.	Roue avant p/motée	Vormontiertes vorderrad	Rueda delantera montada
2	15.17500.000	1		Fermafascioni	Tire fastener	Caoutchouc serrure chambre	Reifen Halter	Agarre cubierta ant.
3	23.10100.000	32		Nipples	Nipples	Nipples	Nippel	Nipples
4	27.24192.000	16		Raggio 3.254 c.169	Spoke 3.254 c.169	Rayon 3.254 c.169	Speiche 3.254 c.169	Radio 3.254 c.169
5	27.24193.000	16		Raggio 3.256 c.169	Spoke 3.256 c.169	Rayon 3.256 c.169	Speiche 3.256 c.169	Radio 3.256 c.169
6	12.97900.000	2		Cuscinetto 61904	Ball bearing 61904	Roulement 61904	Kugellager 61904	Cojinete 61904
8	007.41.030.00.00	1		Perno ruota anteriore	Front wheel spindle	Pivot roue AV.	Vorderradzapfen	Perno ruota delantera
11	15.38200.000	1		Flap 21x25	Bead 21x25	Flap 21x25	Felgenband 21x25	Cinta tapa radios "flap" 21x25
12	007.41.015.80.59	1		Mozzo ruota	Hub	Moyeu roue	Radnabe	Buje ruoda
13	12.42531.000	1		Cerchio 21.1,6-32	Rim 21.1,6-32	Jante roue 21.1,6-32	Felge 21.1,6-32	Aro 21.1,6-32
14	13.39279.000	1		Disco freno ant.	Front brake disk	Disque frein avant	Vorderbrems Scheibe	Disco freno delantero
15	27.57510.000	4		Rondella	Washer	Rondelle	U.Scheibe	Arandela
16	11.49513.000	4		Vite 6.25	Screw 6.25	Vis 6.25	Schraube 6.25	Tornillo 6.25
17	007.41.003.00.00	1		Distanziale interno	Inner spacer	Entretoise interne	Inneres Distanzstück	Distanciadador interior
18	13.62251.000	4		Distanziale	Spacer	Entretoise	Distanzstück	Distanciadador
19	13.17120.000	1		Dado flangiato M8	Flanged nut M8	Ecrou bordé M8	Flanschmutter M8	Tuerca embreada M8
20	22.31980.000	8		Molla a tazza	Belleville spring	Ressort à godet	Tassenfeder	Muelle de taza

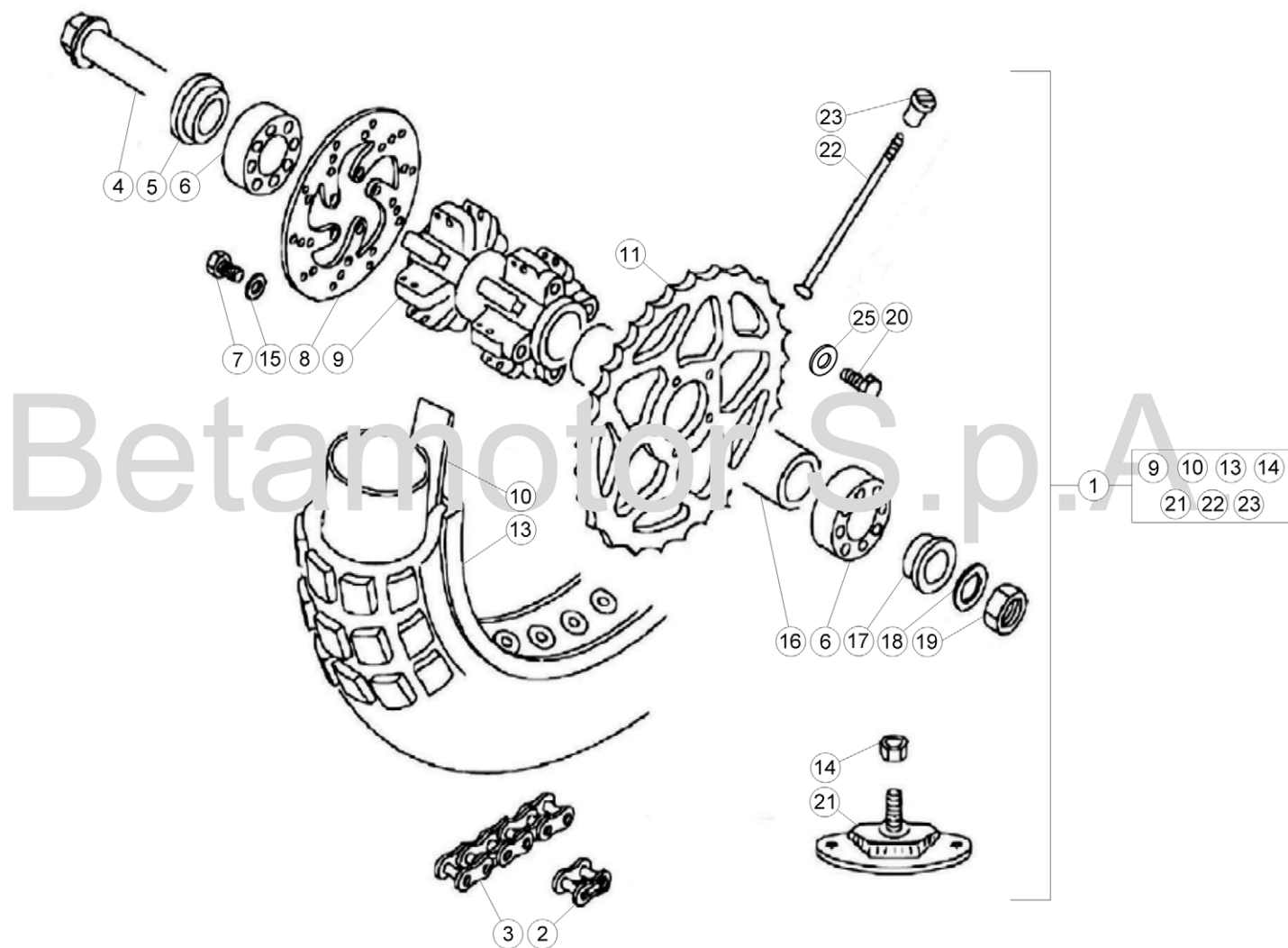

© Copyright 2016 Betamotor S.p.A.



# Tav.42A

Pos Loc Ps Pos	Numero Number Numéro Número Nummer	Q.tà Q.ty Q.té M.ge C.ad	Nota Note Note Nota Anm.	Descrizione	Description	Désignation	Beschreibung	Descrìcion
								<b>JUNIOR</b>
1	012.42.037.00.00	1		Ruota posteriore premontata	Rear wheel assy.	Roue arrière p/motée	Vormontiertes hinterrad	Rueda trasera montada
2	012.42.005.00.00	1		Maglia congiunzione 1/2x5/16	Connecting link 1/2x5/16	Maillon jonction 1/2x5/16	Kettenschloss 1/2x5/16	Enganche cadena 1/2x5/16
3	012.42.003.00.00	1		Catena 1/2 5/16 p.114	Chain 1/2 5/16 p.114	Chaîne 1/2 5/16 p.114	Kette 1/2 5/16 p.114	Cadena 1/2 5/16 p.114
4	25.55815.000	1		Perno ruota posteriore	Rear wheel pin	Pivot roue arrière	Hinterradbolzen	Perno ruoda trasera
5	13.85767.000	1		Distanziale dx.	R.H. spacer	Entretoise droite	Rechtes Distanzstück	Distanciadór Der.
6	12.94010.000	2		Cuscinetto	Bearing	Roulement	Lager	Cojinete
7	11.49010.000	5		Bullone M6x20 TE	Bolt M6x20 TE	Boulon M6x20 TE	Bolzen M6x20 TE	Tornillo M6x20 TE
8	13.39413.000	1		Disco freno post.	Rear brake disc	Disque frein arr.	Bremsscheibe	Disco freno trasero
9	22.08042.059	1		Mozzo completo	Hub, assy.	Moyeu compl.	Nabe, kompl.	Buje compl.
10	15.36000.000	1		Flap 17/18x25	Bead 17/18x25	Flap 17/18x25	Felgenband 17/18x25	Flap cinta tapa radios 17/18x25
11	12.89589.000	1		Corona 1/2 5/16 z.54	Ring gear 1/2 5/16 z.54	Couronne 1/2 5/16 z.54	Zahnkranz 1/2 5/16 z.54	Corona 1/2 5/16 z.54
13	12.42865.003	1		Cerchio ruota post. 1,60-17-1-00	Rear wheel rim 1,60-17-1-00	Jante roue AR. 1,60-17-1-00	Hinterradfelge 1,60-17-1-00	Llanta ruoda trasera 1,60-17-1-00
14	13.17120.000	1		Dado flangiato M8	Flanged nut M8	Ecrou bordé M8	Flanschmutter M8	Tuerca embrodada M8
15	27.40470.000	5		Rondella 6,4.10.0,7	Washer 6,4.10.0,7	Rondelle 6,4.10.0,7	U.Scheibe 6,4.10.0,7	Arandela 6,4.10.0,7
16	13.62716.000	1		Distanziale interno	Inner spacer	Entretoise interne	Inneres Distanzstück	Distanciadór interior
17	13.85769.000	1		Distanziale sx.	L.H. spacer	Entretoise gauche	Linkes Distanzstück	Distanciadór lzq.
18	27.55600.000	1		Rondella 12x24	Washer 12x24	Rondelle 12x24	Scheibe 12x24	Arandela 12x24
19	13.21150.000	1		Dado m12 p. 1,25	Nut m12 p. 1,25	Ecrou m12 p. 1,25	Mutter m12 p. 1,25	Tuerca m12 p. 1,25
20	11.50590.000	5		Bullone 7.20 ch 11 rs	Bolt 7.20 ch 11 rs	Boulon 7.20 ch 11 rs	Bolzen 7.20 ch 11 rs	Tornillo 7.20 ch 11 rs
21	15.17501.000	1		Fermafascioni post.	Tire fastener, rear	Caoutchouc serrure chambre AR.	Reifen Halter, hinten	Agarre cubierta tras.
22	27.23831.000	36		Raggio 3x201 C.169 C.2,1	Spoke 3x201 C.169 C.2,1	Rayon 3x201 C.169 C.2,1	Speiche 3x201 C.169 C.2,1	Radio 3x201 C.169 C.2,1
23	23.10060.000	36		Niplo	Nipple	Ecrou	Nippel	Tuerca
25	27.46500.000	5		Rondella 7.14	Washer 7.14	Rondelle 7.14	U.Scheibe 7.14	Arandela 7.14

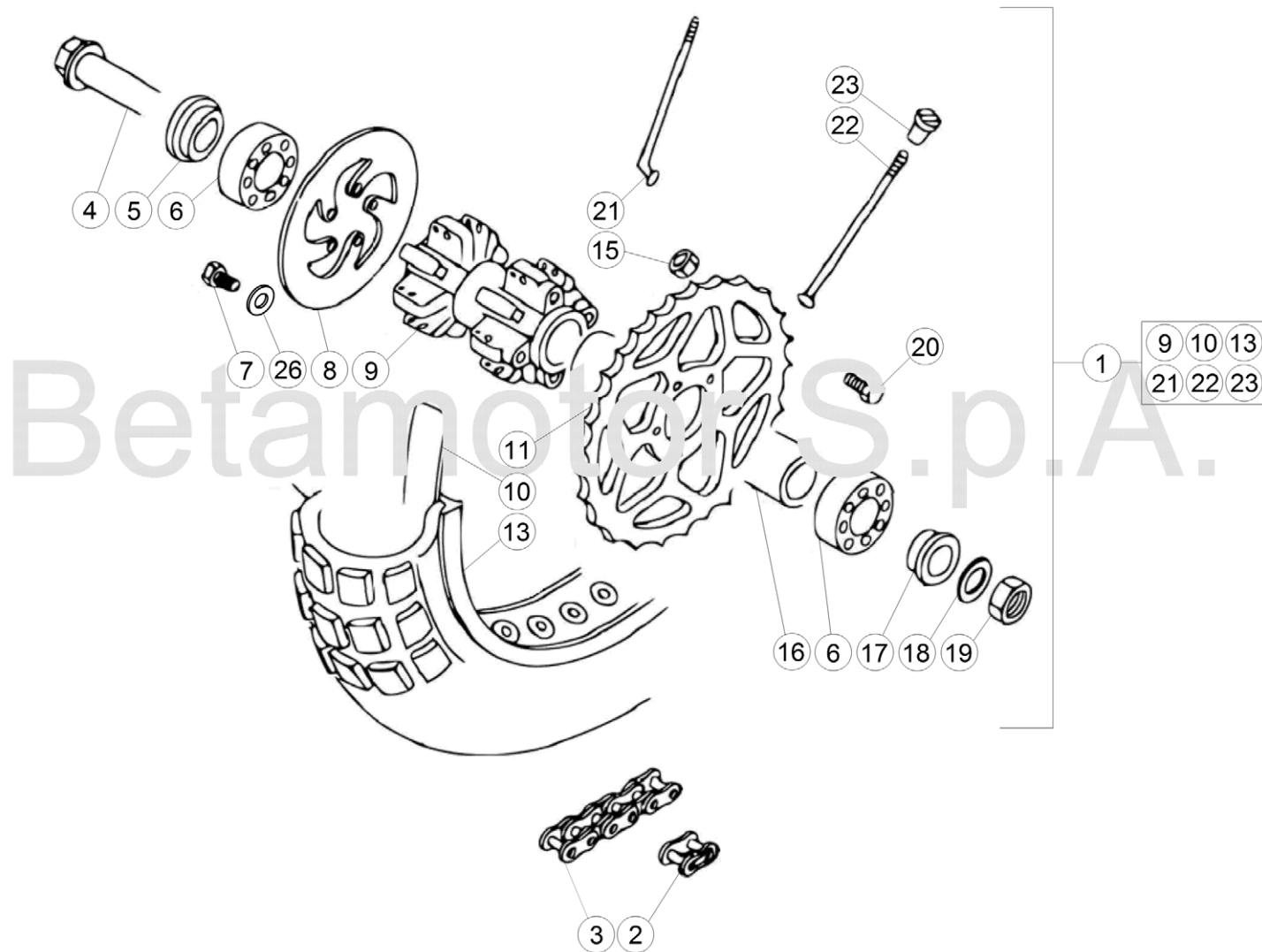

© Copyright 2017 Betamotor S.p.A.

# Tav.42B

Pos Loc Ps Pos	Numero Number Numéro Número Nummer	Q.tà Q.ty Q.té M.ge C.ad	Nota Note Note Nota Anm.	Descrizione	Description	Désignation	Beschreibung	Descrìpion
								<b>SENIOR</b>
1	012.42.016.00.00	1		Ruota posteriore premontata	Rear wheel assy.	Roue arrière p/motée	Vormontiertes hinterrad	Rueda trasera montada
2	012.42.015.00.00	1		Maglia congiunzione	Connecting link	Maillon jonction	Kettenschloss	Enganche cadena
3	012.42.013.00.00	1		Catena 1/2 5/16 p.121	Chain 1/2 5/16 p.121	Chaîne 1/2 5/16 p.121	Kette 1/2 5/16 p.121	Cadena 1/2 5/16 p.121
4	25.55764.000	1		Perno ruota posteriore	Rear wheel pin	Pivot roue arrière	Hinterradbolzen	Perno ruoda trasera
5	13.87774.000	1		Distanziale mozzo post. Dx	RH rear hub spacer	Entretoise moyeu arriere D.	Distanz li	Distanciadador buje tras. Der.
6	12.98010.000	2		Cuscinetto 20X42X12 stagno	Ball bearing 20x42x12	Roulement 20x42x12 etanche	Kugellager 20x42x12	Cojnete 20.42.12 blindado
7	11.48025.000	4		Bullone 6x16 ch 8 rs	Bolt 6x16 ch 8 rs	Boulon 6x16 ch 8 rs	Bolzen 6x16 ch 8 rs	Tornillo 6x16 ch 8 rs
8	13.39316.000	1		Disco freno post.	Rear brake disc	Disque frein arr.	Bremsscheibe	Disco freno trasero
9	012.42.010.80.59	1		Mozzo ruota posteriore	Rear Hub	Moyeu roue Ar.	Hinterradnabe	Cubo ruoda trasera
10	15.36000.000	1		Flap ruota posteriore	Rear wheel rim strip	Bande roue AR.	Hinterradband	Banda ruoda trasera
11	12.89588.000	1		Corona z.60	Ring gear z.60	Couronne z.60	Zahnkranz z.60	Corona z.60
13	012.42.007.32.00	1		Cerchio posteriore	Rear rim	Jante roue arrière	Felge hinten	Aro trasero
15	13.17123.000	4		Dado TECF M8	Nut TECF M8	Ecrou TECF M8	Mutter TECF M8	Tuerca TECF M8
16	012.42.012.00.00	1		Distanziale interno	Inner spacer	Entretoise interne	Inneres Distanzstück	Distanciadador interior
17	13.85774.000	1		Distanziale sx.	L.H. spacer	Entretoise gauche	Linkes Distanzstück	Distanciadador lzq.
18	27.71210.000	1		Rondella 17,2x33x3	Washer 17,2x33x3	Rondelle 17,2x33x3	Scheibe 17,2x33x3	Arandela 17,2x33x3
19	13.29602.000	1		Dado asse ruota post.	Rear wheel axle nut	Ecrou axe roue AR.	Mutter Hinterradachse	Tuerca eje ruoda tras.
20	31.64032.000	4		Vite tbce 8.20	Screw tbce 8.20	Vis tbce 8.20	Schraube tbce 8.20	Tornillo tbce 8.20
21	27.24203.000	16		Raggio lato disco 3,5.214 c.164	Spoke 3,5.214 c.164	Bras 3,5.214 c.164	Speiche 3,5.214 c.164	Radio 3,5.214 c.164
22	27.24204.000	16		Raggio lato corona 3,5.222 c.169	Spoke 3,5.222 c.169	Bras 3,5.222 c.169	Speiche 3,5.222 c.169	Radio 3,5.222 c.169
23	23.10110.000	32		Nipples ø3,5	Nipples ø3,5	Nipples ø3,5	Nippel ø3,5	Nipples 3,5
26	27.57510.000	4		Rondella	Washer	Rondelle	Scheibe	Arandela

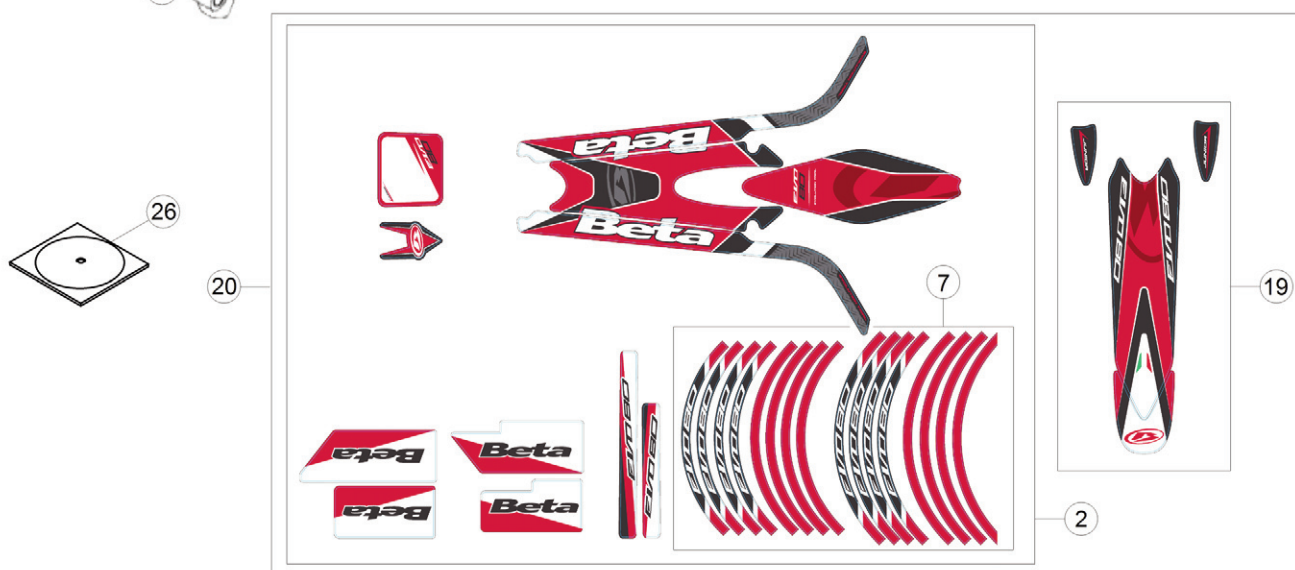
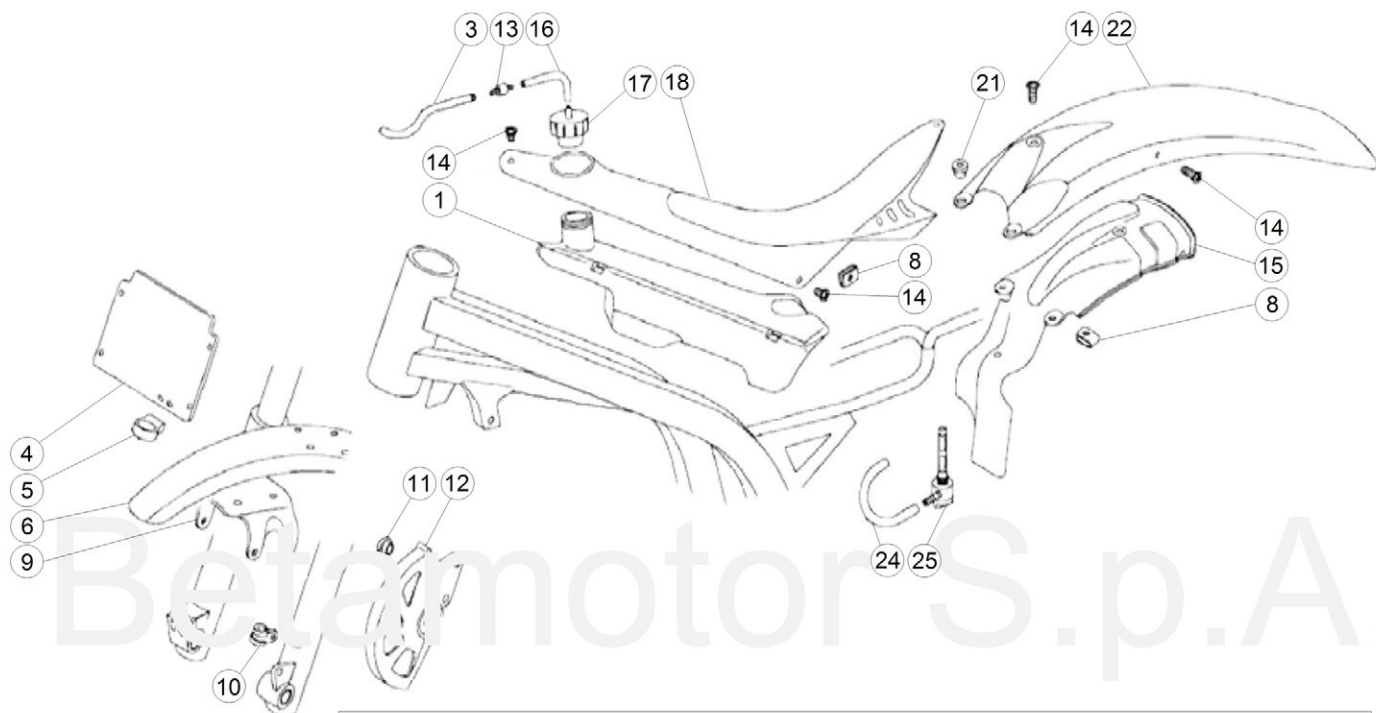

© Copyright 2018 Betamotor S.p.A.

Pos Loc Ps Pos	Numero Number Numéro Número Nummer	Q.tà Q.ty Q.té M.ge C.ad	Nota Note Note Nota Anm.	Descrizione	Description	Désignation	Beschreibung	Descrìcion
								<b>JUNIOR</b>
1	28.06071.000	1		Serbatoio benzina	Fuel tank	Reservoir carb.	Kraftstofftank	Dep. carburante
2	012.43.036.82.00	1		Decalco completamento	Completion decals kit	Kit compl. Decalco	Satz Kleber rahmen	Kit adhesivos para completar.
3	012.43.027.14.00	1		Tubo sfiato	Breather tube	Tuyau réniflard	Entlüftungsleitung	Tubo respiradero
4	22.28852.197	1		Mascherina	Mask	Masque	Maske	Máscara
5	25.24464.000	1		Passacavo	Grommet	Passe-câble	Kabeldurchgang	Pasacables
6	032.43.152.10.59	1		Parafango anteriore	Front mudguard	Garde boue AV.	Vorderradkotflügel	Guardabarros anterior
7	012.43.037.00.00	1		Decalco cerchi	Trimming kit for rims	Jeu enjoliv. jantes	Abziehbildsatz Felgen	Juego calcom. llantas
8	25.60310.000	4		Piastrina	Plate	Plaque	Plättchen	Placa
9	28.98276.000	1		Staffa supporto parafango	Mudguard bracket	Bride support garde -boue	Kotflügeltragbügel	Brida soporte guardabarros
10	15.14653.000	1		Fascetta	Clamp	Collier	Schelle	Abrazadera
11	13.55240.000	3		Distanziale	Spacer	Entretoise	Distanzstück	Distanciator
12	12.88071.159	1		Copridisco anteriore	Disc cover	Couvre-disque	Scheibenabdeckung	Cubredisco
13	031.43.005.00.00	1		Valvola sfiato serbatoio	Reservoir breather valve	Reniflard réservoir	Behälterentlüftungsventil	Válvula alivio depósito
14	31.30570.000	5		Vite TTLIC 6.20 testa 12	Screw TTLIC 6.20 testa 12	Vis TTLIC 6.20 testa 12	Schraube TTLIC 6.20 testa 12	Tornillo TTLIC 6.20 testa 12
15	25.24655.859	1		Passaruota	Rear wheel house	Passe-roue	Radführung	Pasarueda
16	012.43.028.14.00	1		Tubo sfiato	Breather tube	Tuyau réniflard	Entlüftungsleitung	Tubo respiradero
17	29.00525.059	1		Tappo serbatoio benzina	Fillercap	Bouchon réservoir essence	Benzintankverschluß	Tapón depósito gasolina
18	032.43.056.10.97	1		Copriserbatoio	Fuel tank cover	Couvercle réservoir	Tank-Schutzverkleidung	Cubierta depósito
19	012.43.035.82.00	1		Decalco parafango posteriore	Rear mudguard sticker	Décalcomanie garde boue AR.	Hinterradkotflügel Kleber	Pega guardabarros trasero
20	012.43.038.82.00	1		Decalco completo	Complete decals kit	Kit Decalco complet	Satz Kleber rahmen	Kit completo adhesivos
21	13.62000.000	2		Distanziale	Spacer	Entretoise	Distanzstück	Distanciator
22	25.19582.197	1		Parafango posteriore	Rear mudguard	Garde-boue AR.	Hinterradkotflügel	Guardabarros tras.
24	012.43.005.14.00	1		Tubo benzina	Petrol tube	Tuyau d'essence	Benzinschlauch	Tubo gasolina
25	27.81083.000	1		Rubinetto benzina	Fuel cock.	Robinet melange	Kraftstoffhahn	Grifo mezcla
26	012.44.010.00.00	1		CD Manuale uso e manutenzione	Owner's manual	Manuel d'utilisation et entretien	Bedienungs und	Manual de Uso y Manutención

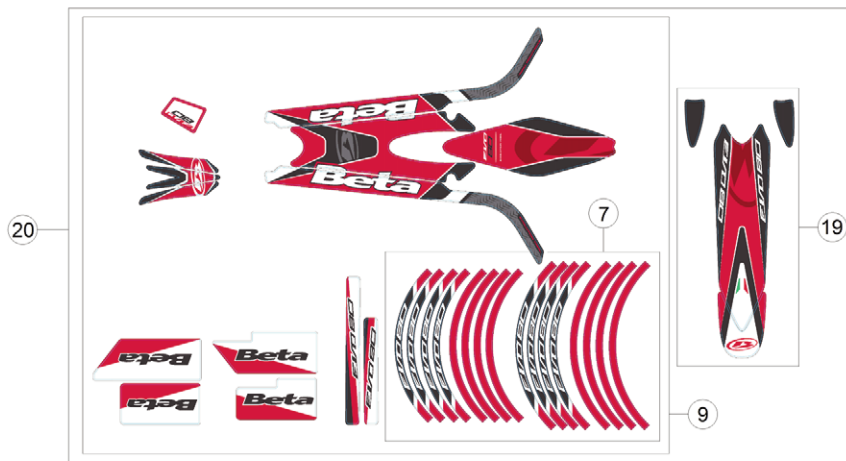
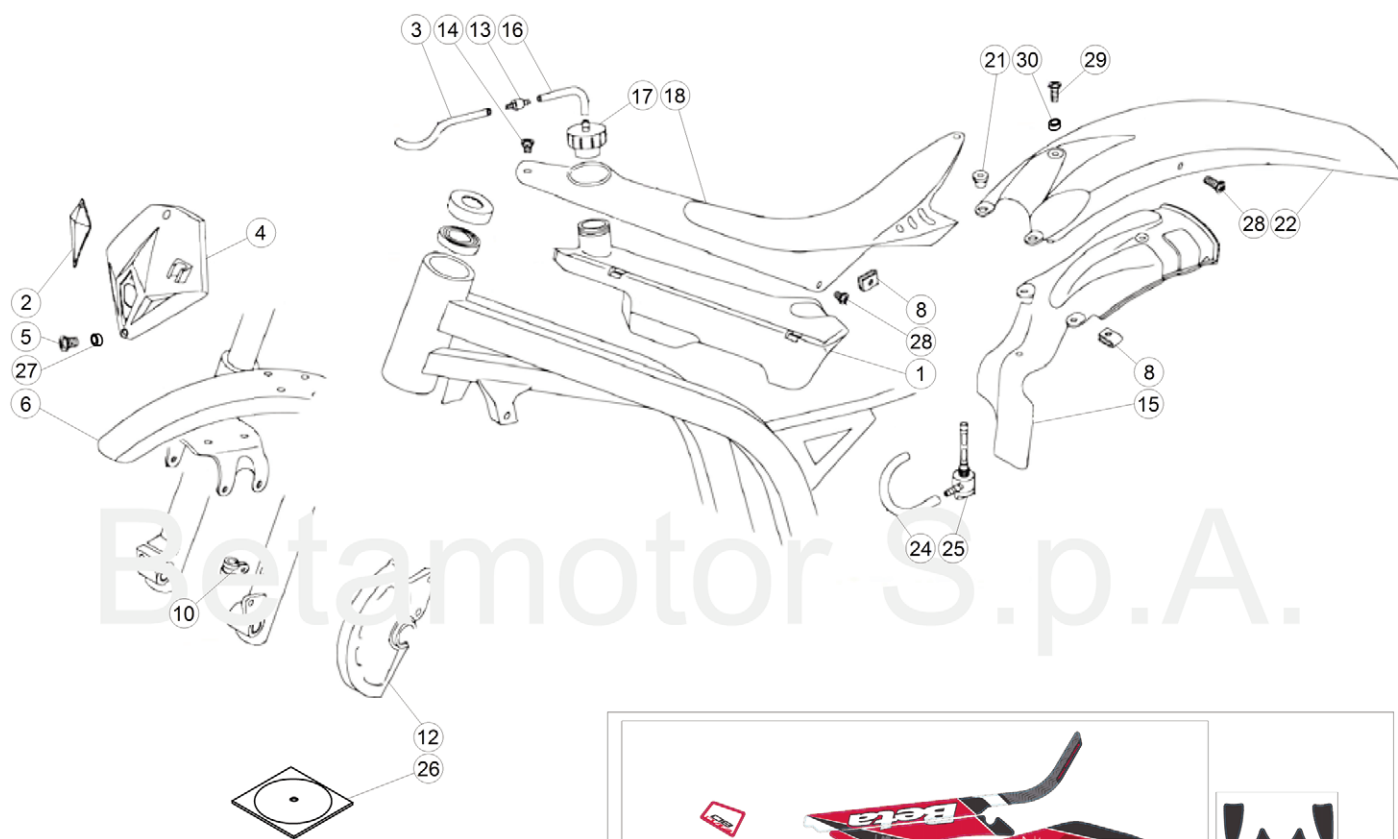

© Copyright 2018 Betamotor S.p.A.

# Tav.43B

Pos Loc Ps Pos	Numero Number Numéro Número Nummer	Q.tà Q.ty Q.té M.ge C.ad	Nota Note Note Nota Anm.	Descrizione	Description	Désignation	Beschreibung	Descrìcion
								<b>SENIOR</b>
1	28.06071.000	1		Serbatoio benzina	Fuel tank	Reservoir carb.	Kraftstofftank	Dep. carburante
2	15.01823.059	1		Fanalino anteriore	Front light	Feu avant	Vorderes licht	Luz delantera
3	012.43.027.14.00	1		Tubo sfciato	Breather tube	Tuyau réinfflard	Entlüftungsleitung	Tubo respiradero
4	22.28697.197	1		Mascherina	Mask	Masque	Maske	Máscara
5	31.29880.000	2		Vite TTLIC M5x25 testa 10	Screw TTLIC M5x25 head 10	Vis TTLIC M5x25 tête 10	Schraube TTLIC M5x25	Tornillo TTLIC M5x25 cabeza 10
6	007.43.010.10.59	1		Parafango anteriore	Front mudguard	Garde boue AV.	Vorderradkotflügel	Guardabarros anterior
7	012.43.037.00.00	1		Decalco cerchi	Trimnings kit for rims	Jeu enjoliv. jantes	Abziehbildsatz Felgen	Juego calcom. llantas
8	25.60310.000	4		Piastrina	Plate	Plaqueette	Plättchen	Placa
9	012.43.036.82.00	1		Decalco completamento	Completion decals kit	Kit compl. Decalco	Satz Kleber rahmen	Kit adhesivos para completar.
10	15.14655.000	1		Fascetta tubo freno	Brake pipe clamp	Collier tube frein disque	Schelle F. Bremserschlauch	Brida fijacion tubo freno
12	007.43.037.00.59	1		Copridisco anteriore	Disc cover	Couvre-disque	Scheibenabdeckung	Cubredisco
13	031.43.005.00.00	1		Valvola sfciato serbatoio	Reservoir breather valve	Reniffard réservoir	Behälterentlüftungsventil	Válvula alivio depósito
14	31.30520.000	1		Vite 6x16 TTLIC	Screw 6x16 TTLIC	Vis 6x16 TTLIC	Schraube 6x16 TTLIC	Tornillo 6x16 TTLIC
15	25.24655.859	1		Passaruota	Rear wheel house	Passe-roue	Radführung	Pasarueda
16	012.43.028.14.00	1		Tubo sfciato benzina	Breather tube	Tuyau réinfflard	Entlüftungsleitung	Tubo respiradero
17	29.00525.059	1		Tappo serbatoio benzina	Fillercap	Bouchon réservoir essence	Benzintankverschluss	Tapón depósito gasolina
18	032.43.056.10.97	1		Copriserbatoio	Fuel tank cover	Couvercle réservoir	Tank-Schutzverkleidung	Cubierta depósito
19	012.43.035.82.00	1		Decalco parafango posteriore	Rear mudguard sticker	Décalcomanie garde boue AR.	Hinterradkotflügel Kleber	Pega guardabarros trasero
20	012.43.038.82.00	1		Decalco completamento	Completion decals kit	Kit compl. Decalco	Satz Kleber rahmen	Kit adhesivos para completar.
21	13.62000.000	2		Distanziale	Spacer	Entretoise	Distanzstück	Distanciadador
22	25.19582.197	1		Parafango posteriore	Rear mudguard	Garde-boue AR.	Hinterradkotflügel	Guardabarros tras.
24	012.43.005.14.00	1		Tubo benzina	Petrol tube	Tuyau d'essence	Benzinschlauch	Tubo gasolina
25	27.81083.000	1		Rubinetto benzina	Fuel cock.	Robinet melange	Kraftstoffhahn	Grifo mezcla
26	012.44.010.00.00	1		CD-ROM manuale uso e manutenzione	Owner's manual CD-ROM	CD-ROM manuel d'utilisation et entretien	Bedienungs und Wartungshandbuch	CD-ROM manual de Uso y Manutención
27	13.54820.000	2		Distanziale	Spacer	Entretoise	Distanzstück	Distanciadador
28	31.30570.000	4		Vite TTLIC 6.20 testa 12	Screw TTLIC 6.20 head 12	Vis TTLIC 6.20 tête 12	Schraube TTLIC 6.20 testa 12	Tornillo TTLIC 6.20 cabeza 12
29	31.30571.000	2		Vite TTLIC 6.25 testa 12	Screw TTLIC 6.25 head 12	Vis TTLIC 6.25 tête 12	Schraube TTLIC 6.25 testa 12	Tornillo TTLIC 6.25 cabeza 12
30	13.54830.000	1		Distanziale	Spacer	Entretoise	Distanzstück	Distanciadador

