

CATALOGO PARTI DI RICAMBIO
CATALOGUE OF SPARE PARTS
CATALOGUE PIECES DE RECHANGE
ERSATZTEILKATALOG
CATALOGO DE PIEZAS DE REPUESTO



Le presenti immagini e i contenuti sono di esclusiva titolarità di Betamotor S.p.A., che si riserva tutti i relativi diritti. Non è consentita alcuna riproduzione, modifica, elaborazione, divulgazione, comunicazione, utilizzazione economica in ogni forma e modo, originale o derivato, che non sia espressamente consentita per iscritto da Betamotor S.p.A. Qualsiasi violazione sarà perseguita da parte di Betamotor S.p.A. in tutte le opportune sedi civili e penali.

The images and content herein are the exclusive property of Betamotor SpA, which reserves all rights thereto. Any reproduction, modification, editing, dissemination, communication, exploitation in any form and way, original or derived, is strictly forbidden if not expressly approved in writing by Betamotor SpA. Any violation will be actively pursued in all relevant civil and criminal forums by Betamotor SpA.

Toutes les images et le contenu qui se trouvent dans ce document sont la propriété exclusive de Betamotor SpA, qui se réserve tous les droits. Toute reproduction, modification, édition, diffusion, communication, ou exploitation sous quelque forme et de quelque manière, originale ou dérivée, est strictement interdite sans l'autorisation écrite expresse de Betamotor SpA. Toute violation sera poursuivie par Betamotor SpA dans toutes les cours civiles et pénales compétentes.

Die vorliegenden Abbildungen und Inhalte sind Alleinbesitz von Betamotor S.p.A., die sich alle diesbezüglichen Rechte vorbehalten. Ohne die ausdrückliche schriftliche Genehmigung von Betamotor S.p.A. ist keine Art von Reproduktion, Änderung, Verarbeitung, Verbreitung, Mitteilung an Dritte, wirtschaftliche Nutzung in jeder Form und auf jede Art, weder im Original noch davon abgeleitet, erlaubt. Jede Zuwiderhandlung wird von Betamotor S.p.A. über alle zuständigen zivil- und strafrechtlichen Gerichtsstellen verfolgt.

Las imágenes y el contenido de este documento son propiedad exclusiva de Betamotor SpA, que se reserva todos los derechos. Cualquier reproducción, modificación, procesamiento, difusión, comunicación, explotación en cualquier forma y manera, originaria o derivada, está estrictamente prohibidas si no está aprobadas expresamente por escrito por Betamotor SpA. Cualquier violación será perseguida por Betamotor SpA en todas las sedes competentes civiles y penales.

TAV.01 Carter completo - Crankcase, assy - Carter complet - Kurbelwellengehäuse, KPL - Carter completo

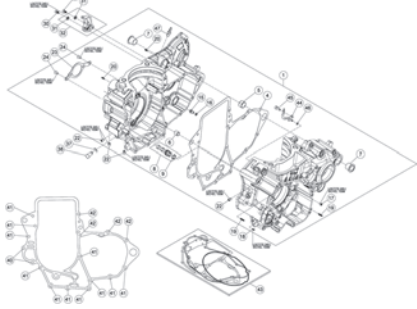

Pag. 6

TAV.01A Coperchio frizione - Clutch cover - Couvercle d'embrague - Kupplungsdeckel - Tapa embrague

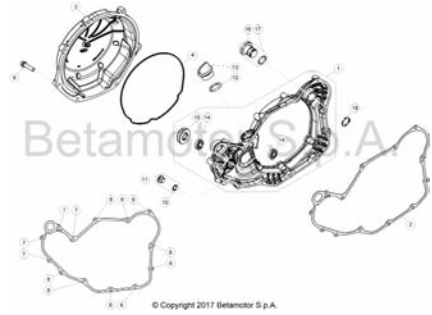

Pag. 8

TAV.02 Albero bilanciamento - Balancer Shaft - Arbre Equilibrage - Ausgleichswelle - Árbol Equilibrado

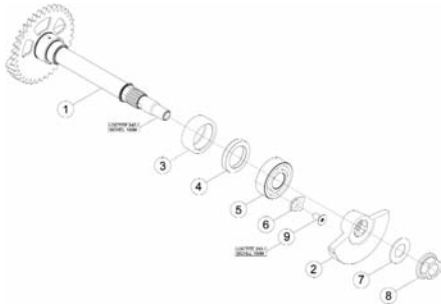

Pag. 9

TAV.02A Albero motore - Crankshaft - Vilebrequin - Kurbelwelle - Cigüeñal

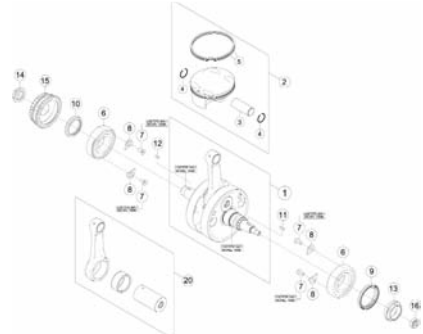

Pag. 10

TAV.03 Frizione - Clutch - Embrayage - Kupplung - Embrague

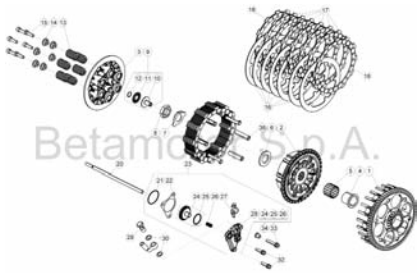

Pag. 12

TAV.04 Ingranaggi cambio - Gear group - Engrenages changement de vitesses - Schaltgetriebe - Engranaje del cambio

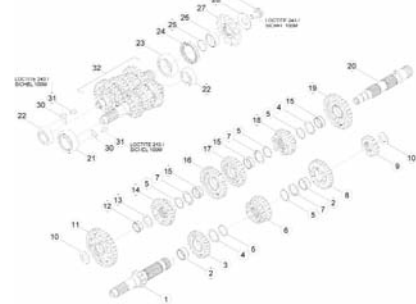

Pag. 14

TAV.05 Comando cambio - Gear shift control - Commande changement de vitesse - Chaltung - Mando cambio

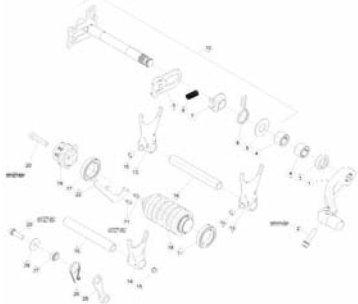

Pag. 16

TAV.07 Avviamento elettrico - Electric starter - Dé marrage électrique - Elektrischer start - Arranque eléctrico

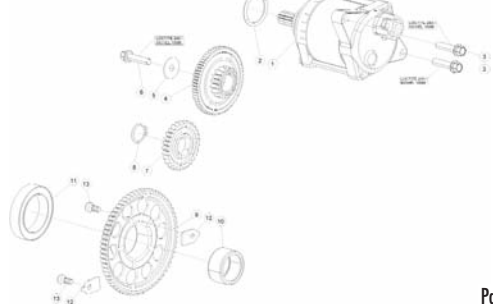

Pag. 17

TAV.08 Impianto di lubrificazione - Lubrication system - Système de lubrification - Schmieranlage - Sistema de lubricación



Pag. 18

TAV.09 Pompa acqua - Water pump - Pompe a eau - Wasserpumpe - Bomba agua

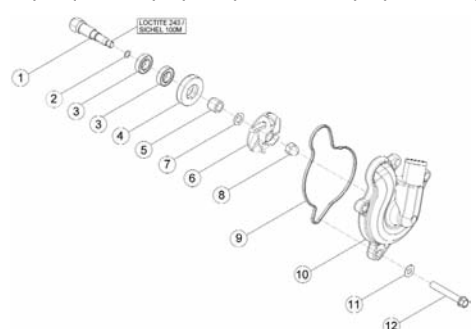

Pag. 20

TAV.10 Gruppo accensione elettronica - Electronic ignition assy. - Groupe allumage électronique - Elektronischezündung gruppe - Grupo encendido electrónico

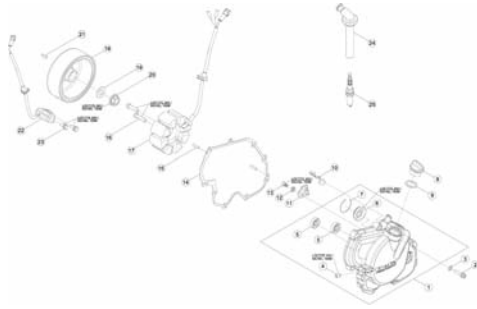

Pag. 21

TAV.11 Cilindro completo - Cylinder, assy - Cylindre complet - Zylinder, KPL. - Cilindro completo

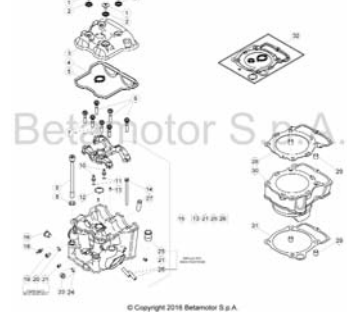

Pag. 22

TAV.11A Valvole-Catena distribuzione - Valves-Timing chain - Soupapes-Chaî ne de distribution - Ventil-Steuerkette - Válvulas-Cadena de distribución

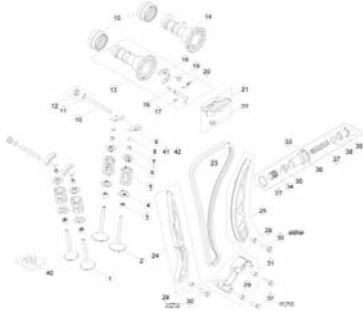

Pag. 24

TAV.13 Gruppo iniezione - Injection unit - Groupe injection - Einspritzung - Grupo iniección

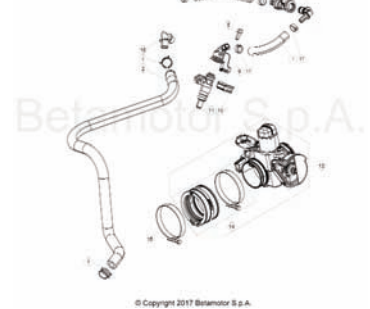

Pag. 28

TAV.14 Attrezzatura specifica - Special tools - Outillage spéciale - Spezialwerkzeug - Utillaje específico

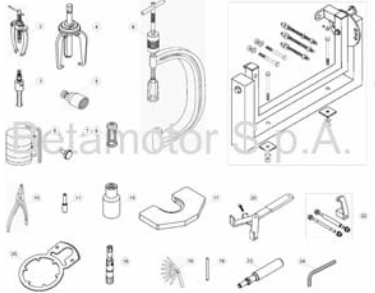

Pag. 30

TAV.31 Telaio - Frame - Chassis - Rahmen - Chasis

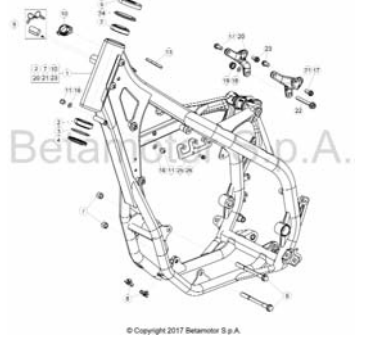

Pag. 32

TAV.32 Accessori telaio - Frame accessories - Accessoires chassis - Rahmenzubehör - Accesorios Chasis



Pag. 34

TAV.33A Ammortizzatore posteriore - Rear damper - Amortisseur arrière - Hinterer Stoßdämpfer

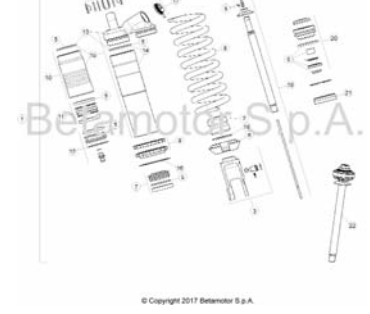

Pag. 36

TAV.33B Forcellone posteriore - Rear fork - Fourche arrière - Hinterradschwinge - Horquilla posterior



Pag. 38

TAV.34 Forcella anteriore - Front fork - Fourche AV. - Vorderradgabel - Horquilla delantera

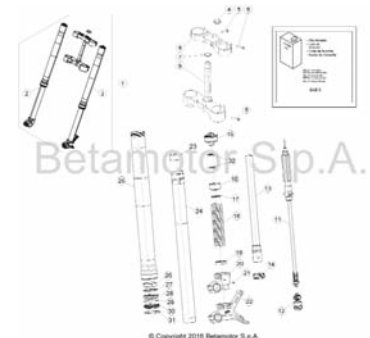

Pag. 40

TAV.35 Comandi-Manubrio - Controls-Handlebars - Commandes-Guidon - Bedienungselemente-Lenker - Mandos-Manillar

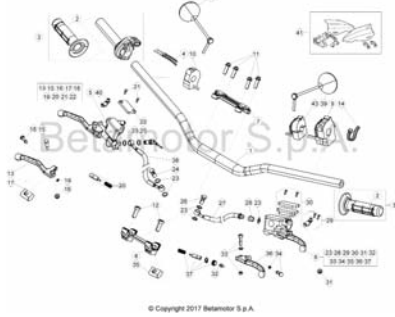

Pag. 42

TAV.36 Impianto freni idraulici - Hydraulic brakes system - Installation des freins hydrauliques - Hydraulischebremse anlage - Instalació n freno hidráulico



Pag. 44

TAV.37 Gruppo scarico - Exhaust system - Echappement - Auspuffanlage - Grupo escape

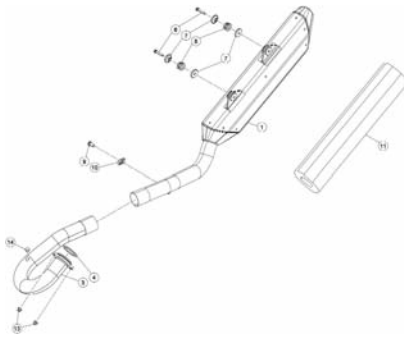

Pag. 46

TAV.38 Scatola filtro - Filter box - Boi tier du filtre - Sicherungskasten - Caja del filtro

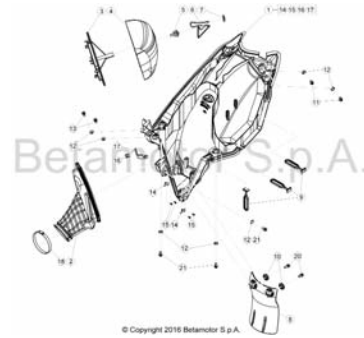

Pag. 47

TAV.39 Impianto di raffreddamento - Installation de refroidissement - Installation de refroidissement - Kühlsystem - Instalació n de enfriamiento

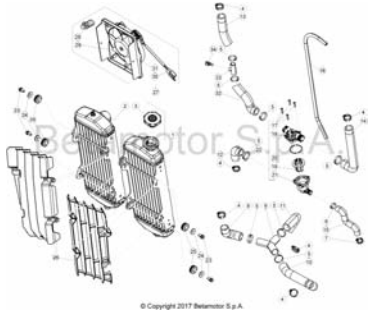

Pag. 48

TAV.40 Impianto elettrico - Electrical equipment - Installation électrique - Elektrische anlage - Instalació n electrica



Pag. 50

TAV.41 Ruota anteriore - Front wheel - Roue AV. - Vorderrad - Rueda delantera



Pag. 54

TAV.42 Ruota posteriore - Rear wheel - Roue AR. - Hinterrad - Rueda trasera

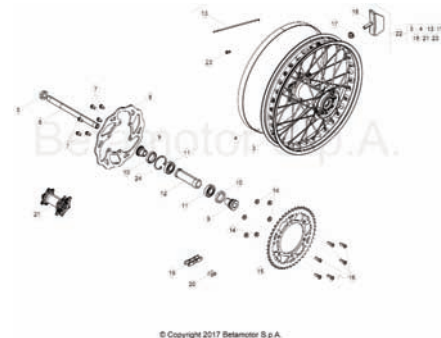

Pag. 56

TAV.43 Carenature-Serbatoio-Sella - Fairings-Tank-Saddle - Carenages-Reservoir-Selle - Verkleidungen-Tank-Sattel - Carenados-Deposito-Sillí n



Pag. 58

TAV.43A Carenature-Parafanghi - Mudguards - Carenages-Gardeboues - Verkleidungen-Kotflü geln - Carenados-Guardabarros



Pag. 60

TAV.44 Attrezzatura specifica - Special tools - Outillage spéciale - Spezialwerkzeug -
Utilaje específico

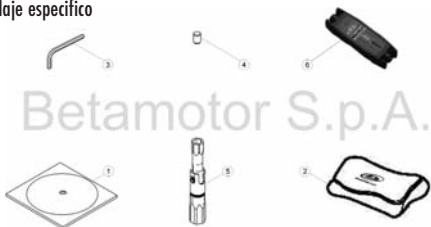

© Copyright 2016 Betamotor S.p.A.

Pag. 62

Tav.01

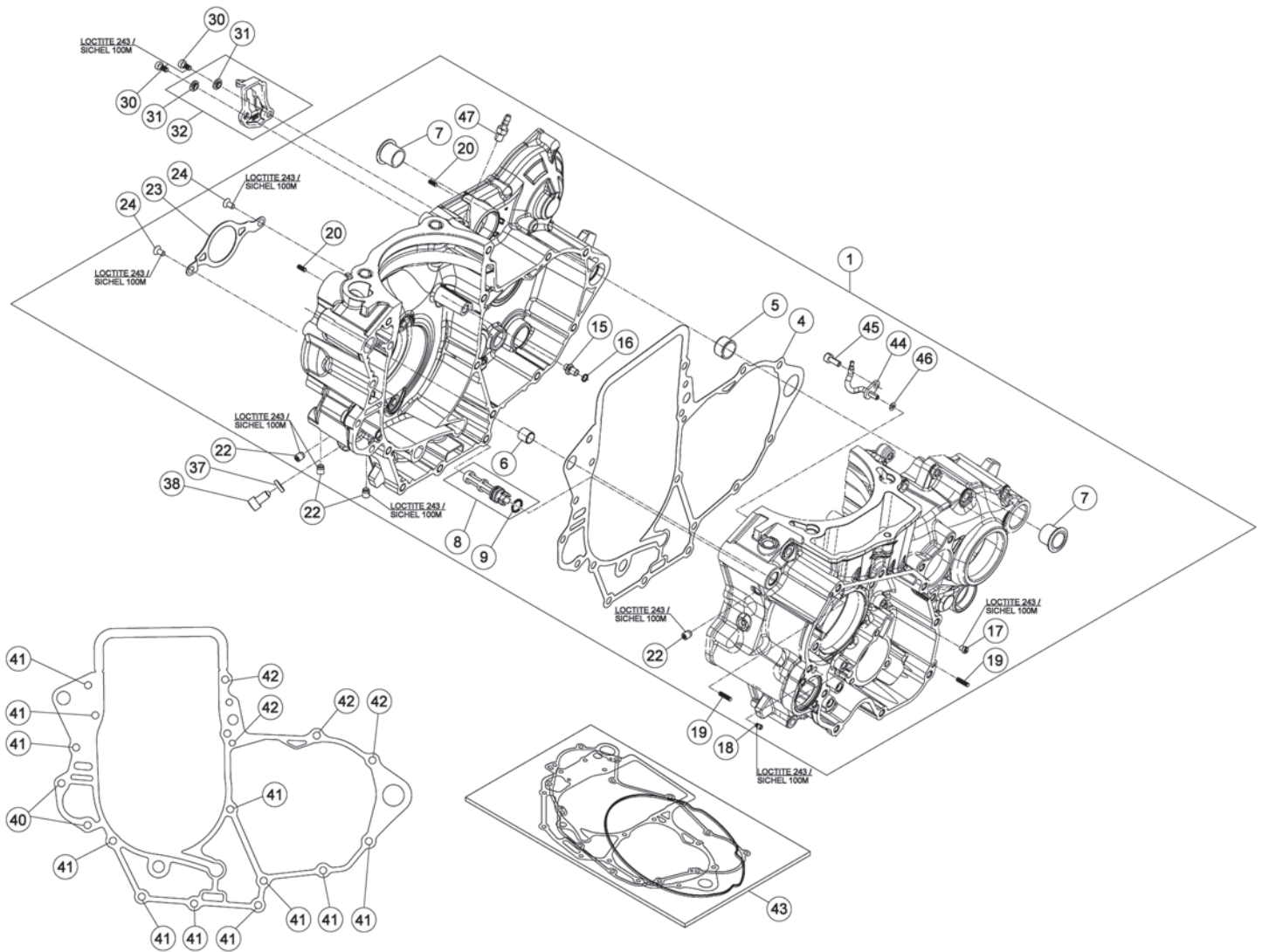

Tav.01

Pos Loc Pos Ps Pos	Numero Number Numéro Número Nummer	Q.tà Q.ty Q.té M.ge C.ad	Nota Note Note Nota Anm.	Descrizione	Description	Dé signation	Beschreibung	Descrìpziò n
1	027.01.000.80.00	1	350-390cc	Carter motore completo	Crankcase assy.	Carter moteru complet	Kurbelgehäuse, kompl.	Carter motor completo
1	029.01.000.80.00	1	430-500cc	Carter motore completo	Crankcase assy.	Carter moteru complet	Kurbelgehäuse, kompl.	Carter motor completo
4	029.01.003.00.00	1		Guarnizione Carter Motore	Crankcase Gasket	Joint Carter Moteur 4t	Motorgehäuse Dichtung	Junta Carter Motor
5	006.01.012.00.00	1		Grano di riferimento 17x21.12	Dowel 17x21.12	Repère 17x21.12	Passtift 17x21.12	Centraje 17x21.12
6	16.41500.000	1		Grano di riferimento	Dowel	Repère	Passtift	Centraje
7	006.01.011.00.00	2		Boccola 17X21X19	Bush 17X21X19	Moyeu 17X21X19	Büchse 17X21X19	Buje 17X21X19
8	006.08.053.80.00	1		Filtro olio	Oil filter	Filtre à huile	Ölfilter	Filtro de aceite
9	10.50010.000	1		Anello OR 8x1,5x	O-Ring 8x1,5x	Bague d' é tanché ité 8x1,5x	O-Ring 8x1,5x	Anillo OR 8x1,5x
15	029.01.024.80.00	1		Getto olio completo	Cooling oil jet, assy	Gicleur huile de refr.	Öldüse	Surtidor aceite de enfr.
16	10.66139.000	1		Anello OR 6 x 1,5	O-Ring 6 x 1,5	Bague d' é tanché ité 6 x 1,5	O-Ring 6 x 1,5	Anillo OR 6 x 1,5
17	16.42903.000	1		Getto lubrificazione 100	Lubrication jet 100	Gliceur lubrification 100	Düse Schmierung 100	Surtidor lubricación 100
18	16.42904.000	1		Getto lubrificazione carter 100	Lubrication jet crankcase 100	Gliceur lubrification carter 100	Düse Schmierung Kurbelwellengehä use 100	Surtidor lubricación cá rter 100
19	12.93384.000	2		Rullino 4x15,8	Roller 4x15,8	Rouleau 4x15,8	Rolle 4x15,8	Rodillo 4x15,8
20	36.25021.000	2		Rullino 4,0 X 9,8	Roller 4,0 X 9,8	Rouleau 4,0 X 9,8	Rolle 4,0 X 9,8	Rodillo 4,0 X 9,8
22	006.01.021.00.00	4		Tappo olio ad espansione 7X9	Oil expansion plug 7X9	Bouchon d' huile à expansion 7X9	Öl-expansionsstopfen 7X9	Tapón extensible del aceite 7X9
23	006.01.018.00.09	1		Piastrina	Plate	Plaquette	Plättchen	Placa
24	31.30085.000	2		Vite M5X10	Screw M5X10	Vis M5X10	Schraube M5X10	Tornillo M5X10
30	C24.24.045.00.00	2		Vite a brugola TCCE 5x10	Allen screw TCCE 5x10	Vis à 6 pans TCCE 5x10	Sechskantschraube TCCE 5x10	Tornillo a llave allen TCCE 5x10
31	006.08.081.00.00	2		Boccola	Bush	Moyeu	Büchse	Buje
32	022.08.080.80.00	1		Rampa olio	Oil incline	Rampe huile	Ölrampe	Diffusor aceite
37	029.01.026.00.00	1		Rondella in rame 8x14.5	Copper washer 8x14.5	Rondelle en cuivre 8x14.5	Kupfer U.Scheibe 8x14.5	Arandela de cobre 8x14.5
38	029.01.025.00.00	1		Vite speciale PMS	Special screw TDC	Vis spéciale PMS	Spezialschraube OT	Tornillo especial PMS
40	11.50300.000	2		Bullone M6x30 RSCH8	Bolt M6x30 RSCH8	Boulon M6x30 RSCH8	Bolzen M6x30 RSCH8	Tornillo M6x30 RSCH8
41	11.05485.000	11		Bullone M6x60 RSCH8	Bolt M6x60 RSCH8	Boulon M6x60 RSCH8	Bolzen M6x60 RSCH8	Tornillo M6x60 RSCH8
42	C24.31.041.00.00	4		Bullone M6x70 RSCH8	Bolt M6x70 RSCH8	Boulon M6x70 RSCH8	Bolzen M6x70 RSCH8	Tornillo M6x70 RSCH8
43	029.01.005.82.00	1		Kit guarnizioni carter	Crankcase gasket kit	Kit des joints carter	Motorgehäuse-Bausatz	Kit de juntas carter
44	029.01.021.00.00	1		Getto olio raffreddamento	Cooling oil jet	Gliceur huile de refr.	Öldüse	Surtidor aceite de enfr.
45	31.26790.000	1		Vite a brugola M4x10	Allen screw M4x10	Vis à 6 pans M4x10	Sechskantschraube M4x10	Tornillo a llave allen M4x10
46	C02.06.054.00.00	1		Anello OR 3,5x1,5	O-Ring 3,5x1,5	Bague d' é tanché ité 3,5x1,5	O-Ring 3,5x1,5	Anillo OR 3,5x1,5
47	29.00280.000	1		Raccordo	Joint	Raccord	Stutzen	Racor

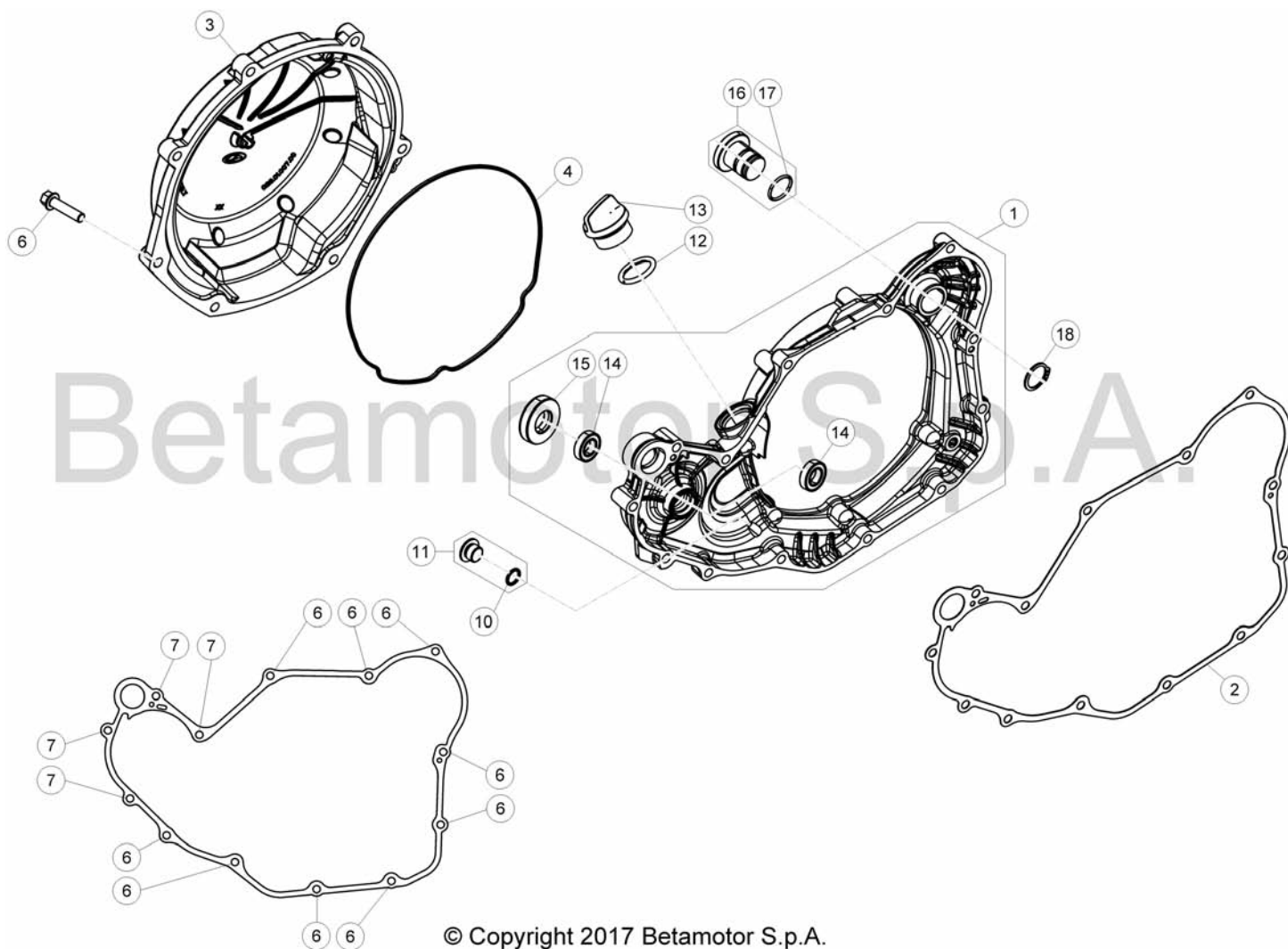

© Copyright 2017 Betamotor S.p.A.

Pos Loc Pos Ps Pos	Numero Number Numéro Número Nummer	Q.tà Q.ty Q.té M.ge C.ad	Nota Note Note Nota Anm.	Descrizione	Description	Dé signation	Beschreibung	Descripció n
1	029.01.030.80.00	1		Coperchio frizione interno	Inner clutch cover	Couvercle interne d'embrayage	Innerer Kupplungsdeckel	Tapa interior embrague
2	029.01.031.00.00	1		Guarnizione coperchio frizione	Clutch cover gasket	Joint couvercle embrayage	Dichtung Kupplungsabdeckung	Junta tapa embrague
3	029.01.007.80.52	1		Coperchio frizione esterno	Outer clutch cover	Couvercle externe d'embrayage	Äußerer Kupplungsdeckel	Tapa exterior embrague
4	006.01.041.00.00	1		Guarnizione coperchio frizione	Clutch cover gasket	Joint couvercle embrayage	Dichtung Kupplungsabdeckung	Junta tapa embrague
6	11.50010.000	16		Bullone M6x25	Bolt M6x25	Boulon M6x25	Bolzen M6x25	Tornillo M6x25
7	11.50360.000	4		Bullone M6x40	Bolt M6x40	Boulon M6x40	Bolzen M6x40	Tornillo M6x40
10	10.50010.000	1		Anello OR 8x1,5x	O-Ring 8x1,5x	Bague d'étanchéité 8x1,5x	O-Ring 8x1,5x	Anillo OR 8x1,5x
11	006.11.045.80.00	1		Tappo Albero coperchio frizione	Clutch cover Arm Plug	Bouchon Arbre Couvercle d'embrayage	Endkappe Kupplungsdeckel	Tapa Ciguena embrague
12	10.66340.000	1		Anello OR 16x3	O-Ring 16x3	Bague d'étanchéité 16x3	O-Ring 16x3	Anillo OR 16x3
13	29.09601.000	1		Tappo carico olio	Oil filling cap	Bouchon rempl. huile	Öleinfüllstüpsel	Tapón introducción aceite
14	12.93400.000	2		Cuscinetto 10x19.5	Bearing 10x19.5	Roulement 10x19.5	Lager 10x19.5	Cojinete 10x19.5
15	10.48030.000	1		Anello paraolio 12x30.7	Oil seal 12x30.7	Joint d'étanchéité 12x30.7	Ölschutzring 12x30.7	Retén de aceite 12x30.7
16	036.01.006.80.59	1		Tappo completo	Plug, assy.	Bouchon complet	Verschluß kpl.	Tapón completo
17	10.66321.000	1		Anello OR	O-Ring	Bague d'étanchéité	O-Ring	Anillo OR
18	33.00070.000	1		Seeger	Circlip	Circlip	Seeger	Seeger

Tav.02

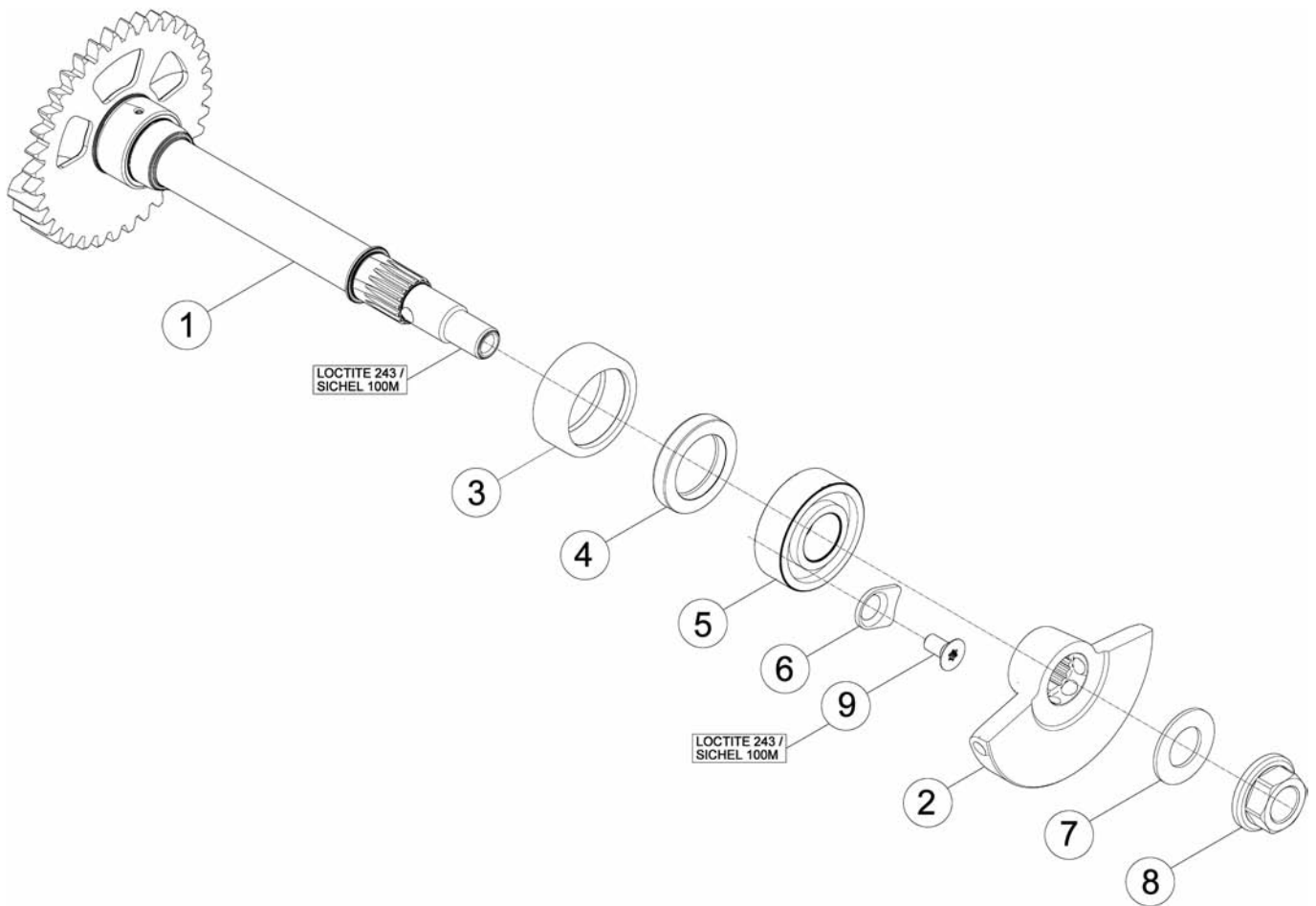

Pos Loc Pos Ps Pos	Numero Number Numéro Número Nummer	Q.tà Q.ty Q.té M.ge C.ad	Nota Note Note Nota Anm.	Descrizione	Description	Dé signation	Beschreibung	Descrìpiòn
1	029.02.020.00.00	1		Albero bilanciamento	Balancer Shaft	Arbre Equilibrage	Ausgleichswelle	Árbol Equilibrado
2	029.02.021.00.00	1		Contrappeso	Counter weight	Contrepoids	Gegengewicht	Contrapeso
3	C06.14.019.00.00	1		Boccola a rulli	Roller bearing	Douille à roulements	Rollenbuchse	Caja de grasa de rodillos
4	10.64490.000	1		Anello paraolio 20x30.5/6	Oil seal 20x30.5/6	Joint d' é tanché ité 20x30.5/6	Ölschutzring 20x30.5/6	Retén de aceite 20x30.5/6
5	C06.01.034.00.00	1		Cuscinetto 15.32.9 6002LLUC3/5K	Bearing 15.32.9 6002LLUC3/5K	Roulement 15.32.9 6002LLUC3/5K	Lager 15.32.9 6002LLUC3/5K	Cojinete 15.32.9 6002LLUC3/5K
6	006.01.016.00.00	1		Piastrina	Plate	Plaquette	Plättchen	Placa
7	27.74810.000	1		Rondella elastica	Spring Washer	Rondelle é lastique	Federring	Arandela elástica
8	13.25010.000	1		Dado M12x1	Nut M12x1	Ecrou M12x1	Mutter M12x1	Tuerca M12x1
9	C24.90.002.00.00	1		Vite TORX M6x12	Screw TORX M6x12	Vis TORX M6x12	Schraube TORX M6x12	Tornillo TORX M6x12

Tav.02A

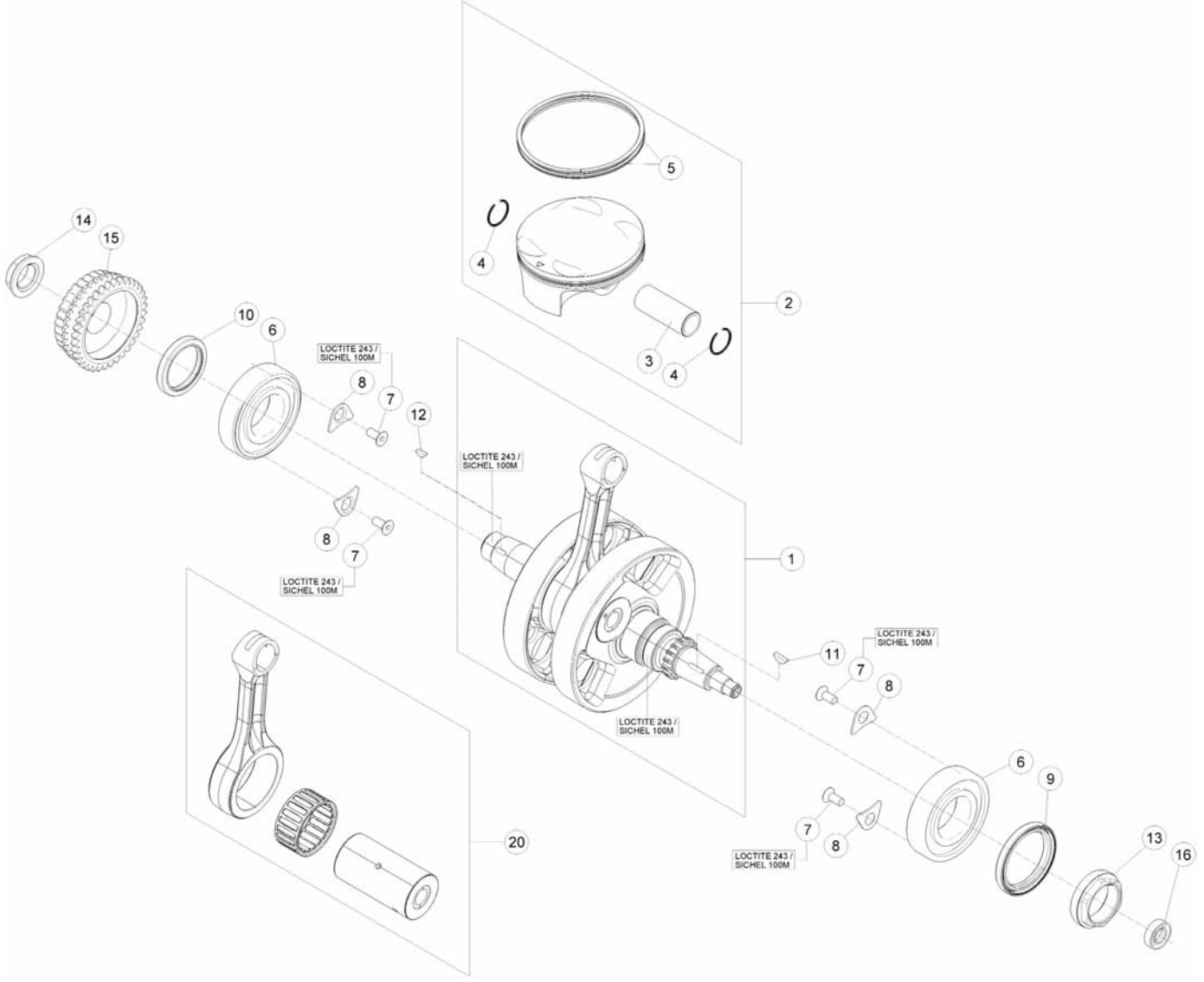

Pos Loc Ps Pos	Numero Number Numé ro Nú mero Nummer	Q.tà Q.ty Q.té M.ge C.ad	Nota Note Note Nota Anm.	Descrizione	Description	Dé signation	Beschreibung	Descrì cì o n
1	027.02.005.80.00	1	350cc	Albero motore completo	Crankshaft, assy.	Arbre moteur complet	kurbelwelle, komplett	Cigü eñ al completo
1	028.02.003.80.00	1	390cc	Albero motore completo	Crankshaft, assy.	Arbre moteur complet	kurbelwelle, komplett	Cigü eñ al completo
1	029.02.000.80.00	1	430-500cc	Albero motore completo	Crankshaft, assy.	Arbre moteur complet	kurbelwelle, komplett	Cigü eñ al completo
2	027.02.150.80.01	1	350cc	Pistone completo 1M	Piston set 1M	Piston compl. 1M	Kolben, kompl. 1M	Pistó n, compl. 1M
2	027.02.150.80.02	1	350cc	Pistone completo 2M	Piston set 2M	Piston compl. 2M	Kolben, kompl. 2M	Pistó n, compl. 2M
2	028.02.150.80.01	1	390cc	Pistone completo 1M	Piston set 1M	Piston compl. 1M	Kolben, kompl. 1M	Pistó n, compl. 1M
2	028.02.150.80.02	1	390cc	Pistone completo 2M	Piston set 2M	Piston compl. 2M	Kolben, kompl. 2M	Pistó n, compl. 2M
2	029.02.050.80.01	1	430cc	Pistone completo 1M	Piston set 1M	Piston compl. 1M	Kolben, kompl. 1M	Pistó n, compl. 1M
2	029.02.050.80.02	1	430cc	Pistone completo 2M	Piston set 2M	Piston compl. 2M	Kolben, kompl. 2M	Pistó n, compl. 2M
2	030.02.050.80.01	1	500cc	Pistone completo 1M	Piston set 1M	Piston compl. 1M	Kolben, kompl. 1M	Pistó n, compl. 1M
2	030.02.050.80.02	1	500cc	Pistone completo 2M	Piston set 2M	Piston compl. 2M	Kolben, kompl. 2M	Pistó n, compl. 2M
3	027.02.051.00.00	1	350-390cc	Spinotto	Pin	Axe	Zapfen	Eje
3	029.02.051.00.00	1	430-500cc	Spinotto	Pin	Axe	Zapfen	Eje
4	022.02.052.00.00	2	350-390cc	Anello ferma spinotto	Piston pin lock ring	Bague de serrage goujon	Bolzenfeststellung	Anillo sujeta pasador
4	029.02.052.00.00	2	430-500cc	Anello ferma spinotto	Piston pin lock ring	Bague de serrage goujon	Bolzenfeststellung	Anillo sujeta pasador
5	027.02.053.80.00	1	350-390cc	Serie segmenti pistone d=88	d=88	d=88	d=88	d=88
5	029.02.053.80.00	1	430cc	Serie segmenti pistone d=95	d=95	d=95	d=95	d=95
5	006.02.153.80.00	1	500cc	Serie segmenti pistone d=100	d=100	d=100	d=100	d=100
6	12.99700.000	2		Cuscinetto 35x72	Bearing 35x72	Roulement 35x72	Lager 35x72	Cojinete 35x72
7	C24.90.002.00.00	4		Vite TORX M6x12	Screw TORX M6x12	Vis TORX M6x12	Schraube TORX M6x12	Tornillo TORX M6x12
8	006.01.016.00.00	4		Piastrina	Plate	Plaquette	Plättchen	Placa
9	10.66085.000	1		Anello paraolio 45x58.7	Oil seal 45x58.7	Joint d' é tanché ité 45x58.7	Ölschutzring 45x58.7	Reté n de aceite 45x58.7
10	10.65900.000	1		Anello paraolio 35x47.6	Oil seal 35x47.6	Joint d' é tanché ité 35x47.6	Ölschutzring 35x47.6	Reté n de aceite 35x47.6
11	12.46020.000	1		Chiavetta 3x5	Key 3x5	Clavette 3x5	Keil 3x5	Chaveta 3x5
12	12.46000.000	1		Chiavetta	Key	Clavette	Keil	Chaveta
13	022.02.011.00.00	1		Dado M32X1	Nut M32X1	Ecrou M32X1	Mutter M32X1	Tuerca M32X1
14	006.03.023.00.00	1		Dado M20X1x5 LH	Nut M20X1x5 LH	Ecrou M20X1x5 LH	Mutter M20X1x5 LH	Tuerca M20X1x5 LH
15	022.03.021.80.00	1	350-390cc	Pignone	Pinion	Pignon	Ritzel	Piñ ó n
15	006.03.121.80.00	1	430-500cc	Pignone	Pinion	Pignon	Ritzel	Piñ ó n
16	10.44690.000	1		Anello paraolio 10x22.6	Oil seal 10x22.6	Joint d' é tanché ité 10x22.6	Ölschutzring 10x22.6	Reté n de aceite 10x22.6
20	027.02.008.80.00	1	350-390cc	Biella completa	Conn.-rod, assy	Bielle compl.	Pleuel, kompl.	Biela compl.
20	029.02.008.80.00	1	430-500cc	Biella completa	Conn.-rod, assy	Bielle compl.	Pleuel, kompl.	Biela compl.

Tav.03

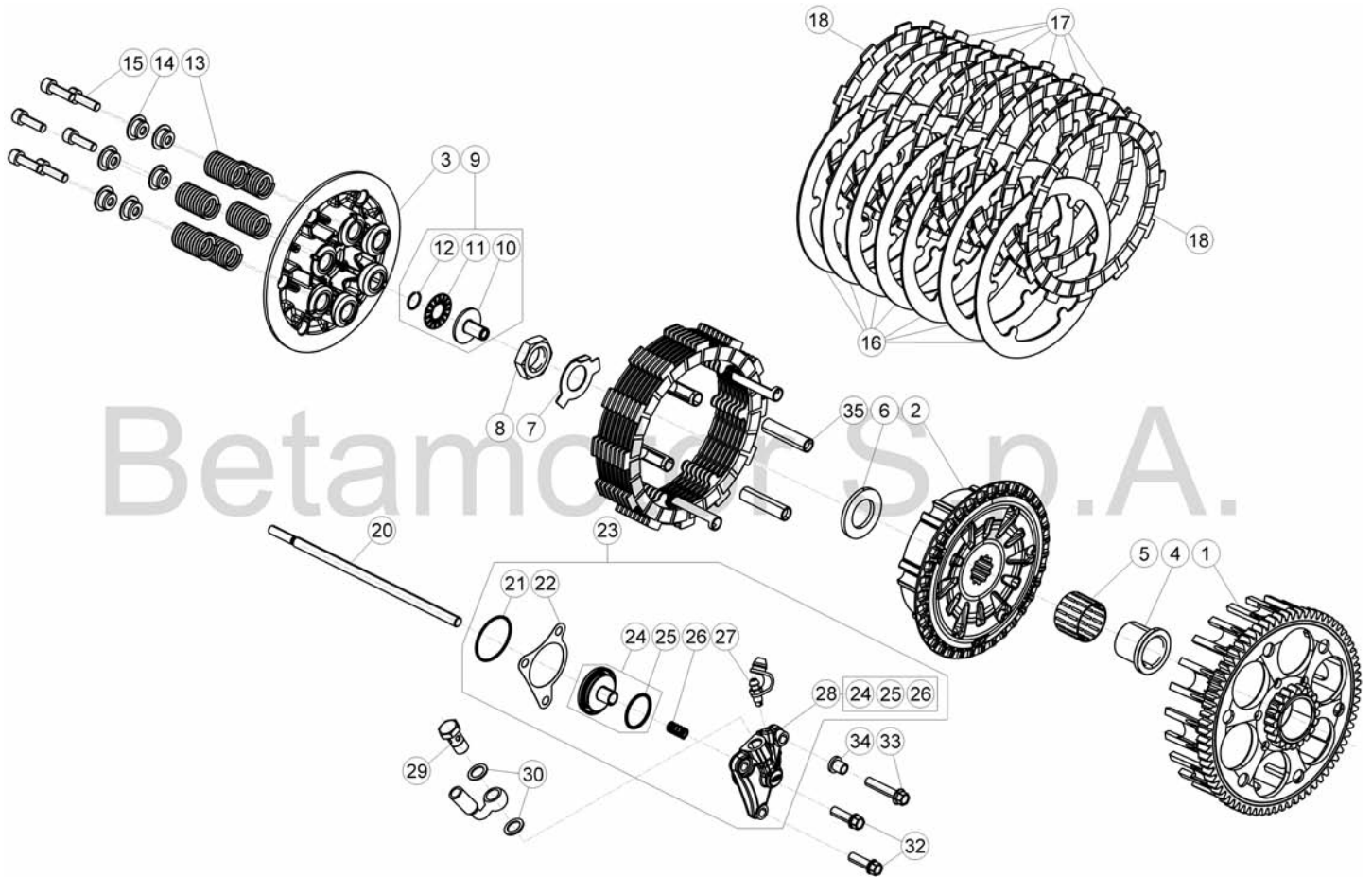

© Copyright 2017 Betamotor S.p.A.

Tav.03

Pos Loc Pos Ps Pos	Numero Number Numé ro Número Nummer	Q.tà Q.ty Q.té M.ge C.ad	Nota Note Note Nota Anm.	Descrizione	Description	Dé signation	Beschreibung	Descrìpziò n
1	027.03.011.00.00	1	350-390cc	Corona trasmissione primaria	Clutch case assembly	Cloche d' embrayage compl.	Kupplungsglocke.	Campana de embr.completa
1	029.03.011.00.00	1	430-500cc	Corona trasmissione primaria	Clutch case assembly	Cloche d' embrayage compl.	Kupplungsglocke.	Campana de embr.completa
2	029.03.141.00.00	1		Mozzo frizione	Clutch drum	Tambour d' embr.	Kupplungstrommel	Tambor de embr.
3	029.03.031.00.00	1		Piattello spingidisco	Spring collar	Godet d' embrayage	Druckteller	Platillo embrague
4	006.03.061.00.00	1		Boccola	Bush	Moyeu	Büchse	Buje
5	006.03.063.00.00	1		Boccola a rulli 26x30.22.	Roller bearing 26x30.22.	Douille à roulements 26x30.22.	Rollenbuchse 26x30.22.	Caja de grasa de rodillos 26x30.22.
6	006.03.062.00.00	1		Rondella 21,7x38.3.	Washer 21,7x38.3.	Rondelle 21,7x38.3.	U.Scheibe 21,7x38.3.	Arandela 21,7x38.3.
7	029.03.000.48.00	1		Rondella di sicurezza	Tab washer	Rondelle de sûreté	Sicherungs-Unterlegscheibe	Arandela de seguridad
8	006.03.065.00.00	1		Dado M18x1,5 h9	Nut M18x1,5 h9	Ecrou M18x1,5 h9	Mutter M18x1,5 h9	Tuerca M18x1,5 h9
9	029.03.071.80.00	1		Innesto Asta Corpo Frizione comp.	Clutch Housing Rod Coupling, assy	Crabot Tige Corps Embrayage compl.	Stabeinklupplung	Acople Varilla Cuerpo Embrague comp.
10	029.03.071.00.00	1		Innesto Asta Corpo Frizione	Clutch Housing Rod Coupling	Crabot Tige Corps Embrayage	Stabeinklupplung	Acople Varilla Cuerpo Embrague
11	16.11370.000	1		Gabbia reggispinta 15x28x2	Thrust bearing cage 15x28x2	Buté e à aiguilles 15x28x2	Andruckkäfig 15x28x2	Jaula cojinete de empuje 15x28x2
12	28.23105.000	1		Seeger RB14 DIN 7993	Circlip RB14 DIN 7993	Circlip RB14 DIN 7993	Seeger RB14 DIN 7993	Seeger RB14 DIN 7993
13	029.03.055.00.00	6		Molla frizione	Clutch spring	Ressort embr.	Kupplg.feder	Muelle embr.
14	029.03.056.00.00	6		Reggimolla Frizione	Spring Retainer	Porte-Ressort Embrayage	Federteller	Portamuelle Embrague
15	31.34510.000	6		Vite TCCE 6.20	Screw TCCE 6.20	Vis TCCE 6.20	Schraube TCCE 6.20	Tornillo TCCE 6.20
16	029.03.150.00.00	7		Disco condotto	Driven plate	Disque entraîné	Scheibe getrieben	Disco conducido
17	029.03.053.00.00	6		Disco conduttore	Driving plate	Disque menant	Scheibe treibend	Disco conductor
18	029.03.054.00.00	2		Disco conduttore	Driving plate	Disque menant	Scheibe treibend	Disco conductor
20	006.03.070.00.00	1		Asta comando frizione	Clutch control rod	Tige de commande embrayage	Klupplungssteuerungsstab	Varilla mando embrague
21	10.66840.000	1		Anello OR 33x1,5	O-Ring 33x1,5	Bague d' é tanché ité 33x1,5	O-Ring 33x1,5	Anillo OR 33x1,5
22	006.03.085.00.00	1		Guarnizione frizione	Clutch lining	Garniture embrayage	Kupplungsbelag	Forro de embrague
23	029.03.080.80.00	1		Corpo attuatore completo	Actuator body, assy.	Corps actionneur complet	Gehäuse Stellantrieb kpl.	Cuerpo del actuador completo
24	029.03.081.80.00	1		Pistone attuatore completo	Actuator piston, assy.	Piston actionneur complet	Kolben Stellantrieb kpl.	Pistón del actuador completo
25	10.66520.000	1		Anello OR 23,52X1,78	O-Ring 23,52X1,78	Bague d' é tanché ité 23,52X1,78	O-Ring 23,52X1,78	Anillo OR 23,52X1,78
26	006.03.083.00.00	1		Molla	Spring	Ressort	Feder	Muelle
27	28.91050.000	1		Tappo sfiato	Breather plug	Bouchon reniflard	Verschluß Entlüfter	Tapón respiradero
28	029.03.080.00.00	1		Corpo attuatore frizione	Actuator body	Corps actionneur	Gehäuse Stellantrieb	Cuerpo del actuador
29	11.65040.000	1		Bullone forato 10x1 x tubo freno	Special bolt	Boulon 10x1 x tube frein	Hohlschraube F.Bremse	Tornillo esp. talad.10.1
30	16.50510.000	2		Guarnizione 10x15x1 in rame	Gasket 10x15x1 copper	Joint 10x15x1 cuivre	Dichtung 10x15x1 Kupfer	Junta 10.15.1 (cobre)
32	11.49070.000	2		Bullone 6x20 ch rs	Bolt 6x20 ch rs	Boulon 6x20 ch rs	Bolzen 6x20 ch rs	Tornillo 6x20 ch rs
33	11.50300.000	1		Bullone 6x30 ch rs	Bolt 6x30 ch rs	Boulon 6x30 ch rs	Bolzen 6x30 ch rs	Tornillo 6x30 ch rs
34	13.49190.000	1		Distanziale 10mm	Spacer 10mm	Entretoise 10mm	Distanzstück 10mm	Distanciadador 10mm
35	029.03.107.00.00	6		Guida disco	Plate guide	Guide-disque	Scheibeführung	Gui a disco

Tav.04

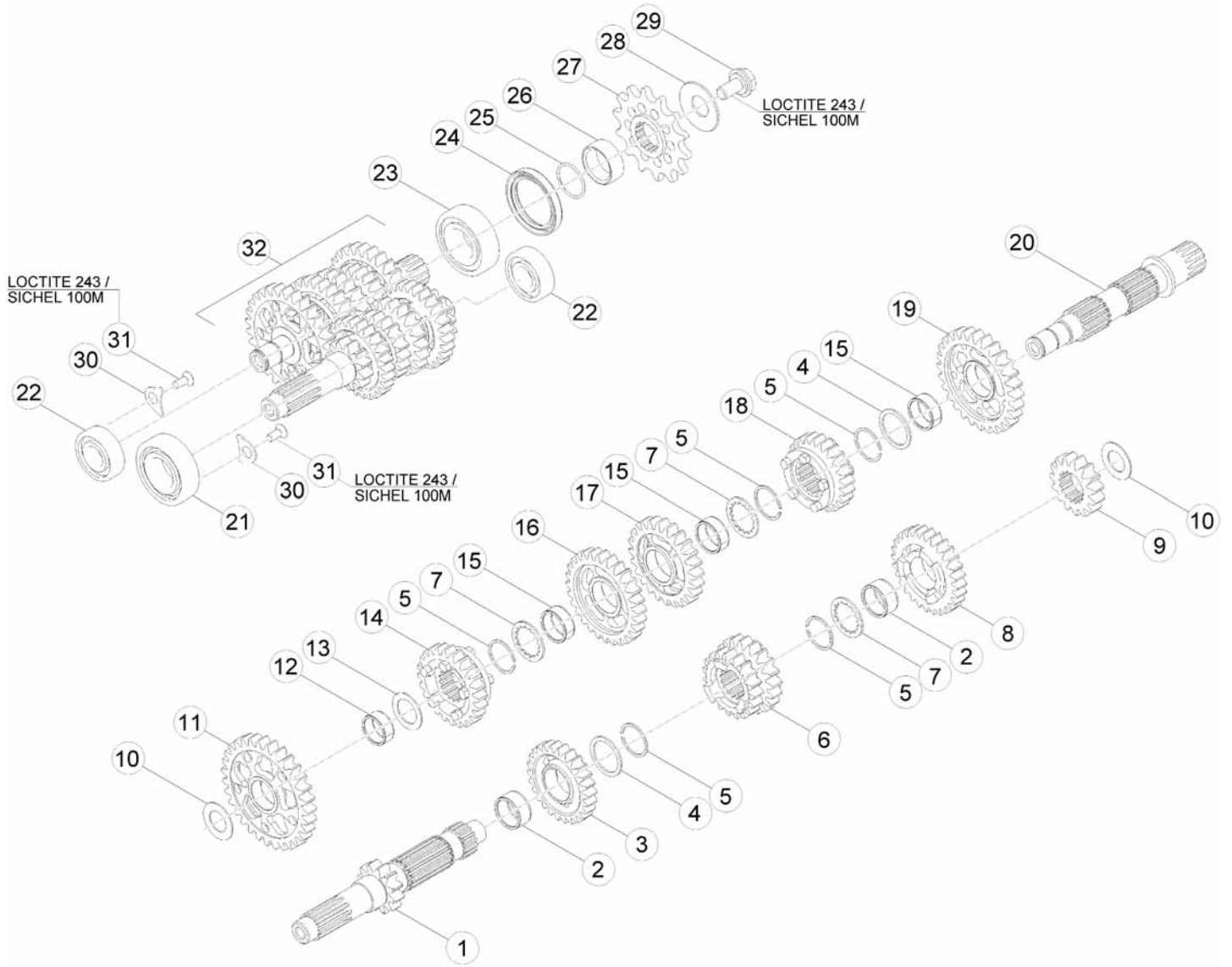

Tav.04

Pos Loc Pos Ps Pos	Numero Number Numé ro Número Nummer	Q.tà Q.ty Q.té M.ge C.ad	Nota Note Nota Anm.	Descrizione	Description	Dé signation	Beschreibung	Descrìpçì n
1	006.04.010.00.00	1		Albero primario	Mainshaft	Arbre primaire	Hauptwelle	Arbol primario
2	11.22855.000	2		Gabbia a rulli 22x26x13	Roller cage 22x26x13	Cage a roul. 22x26x13	Rollenkäfig 22x26x13	Jaula de rod. 22x26x13
3	006.04.015.00.00	1		Quinta sul primario	Fifth gear - mainshaft	Cinquième sur le primaire	5. Gang auf antriebswelle	Quinta marcha en el cigü eñ al primario
4	006.04.031.00.00	2		Rondella rasamento	Thrust washer	Rondelle de butée	Anlaufscheibe	Arandela distanciadora
5	28.25520.000	5		Seeger SW25	Circlip SW25	Circlip SW25	Seeger SW25	Seeger SW25
6	006.04.013.00.00	1		Terza e quarta sul primario	Third and fourth gear - mainshaft	Troisième et quatrième sur le primaire	3. Gang und 4. Gang auf antriebswelle	Tercera y Cuarta marcha en el cigü eñ al primario
7	006.04.030.00.00	3		Rondella rasamento	Thrust washer	Rondelle de butée	Anlaufscheibe	Arandela distanciadora
8	006.04.016.00.00	1		Sesta sul primario	6th gear - mainshaft	Sixième sur le primaire	6. Gang auf antriebswelle	Sexta marcha en el cigü eñ al primario
9	006.04.012.00.00	1		Seconda sul primario	Second gear - mainshaft	Deuxième sur le primaire	2. Gang auf abtriebswelle	Segunda marcha en el cigü eñ al primario
10	006.04.032.00.00	2		Rondella rasamento 17x30x1	Thrust washer 17x30x1	Rondelle de butée 17x30x1	Anlaufscheibe 17x30x1	Arandela distanciadora 17x30x1
11	006.04.021.00.00	1		Prima sul secondario	First gear - layshaft	Première sur le secondaire	1. Gang auf Vorgelegewelle	Primera marcha en el cigü eñ al secundario
12	11.22835.000	1		Gabbia a rulli 20x24x10	Roller cage 20x24x10	Cage a roul. 20x24x10	Rollenkäfig 20x24x10	Jaula de rod. 20x24x10
13	006.04.033.00.00	1		Rondella rasamento 20x30x1	Thrust washer 20x30x1	Rondelle de butée 20x30x1	Anlaufscheibe 20x30x1	Arandela distanciadora 20x30x1
14	006.04.025.00.00	1		Quinta sul secondario	Fifth gear - layshaft	Cinquième sur le secondaire	5. Gang auf Vorgelegewelle	Quinta marcha en el cigü eñ al secundario
15	11.22845.000	3		Gabbia a rulli 22x26x10	Roller cage 22x26x10	Cage a roul. 22x26x10	Rollenkäfig 22x26x10	Jaula de rod. 22x26x10
16	006.04.023.00.00	1		Terza sul secondario	Third gear - layshaft	Troisième sur le secondaire	3. Gang auf Vorgelegewelle	Tercera marcha en el cigü eñ al secundario
17	006.04.024.00.00	1		Quarta sul secondario	Fourth gear - layshaft	Quatrième sur le secondaire	4. Gang auf Vorgelegewelle	Cuarta marcha en el cigü eñ al secundario
18	006.04.026.00.00	1		Sesta sul secondario	6th gear - layshaft	Sixième sur le secondaire	6. Gang auf Vorgelegewelle	Sexta marcha en el cigü eñ al secundario
19	006.04.022.00.00	1		Seconda sul secondario	Second gear - layshaft	Deuxième sur le secondaire	2. Gang auf Vorgelegewelle	Segunda marcha en el cigü eñ al secundario
20	006.04.040.00.00	1		Albero secondario	Counter shaft	Arbre secondaire	Nebengetriebewelle	Eje secundario
21	12.95610.000	1		Cuscinetto 6205	Bearing 6205	Roulement 6205	Lager 6205	Cojinete 6205
22	12.95605.000	2		Cuscinetto 6203	Bearing 6203	Roulement 6203	Lager 6203	Cojinete 6203
23	12.99710.000	1		Cuscinetto NJ205	Bearing NJ205	Roulement NJ205	Lager NJ205	Cojinete NJ205
24	10.66020.000	1		Anello paraolio 32x45x6x5	Oil seal 32x45x6x5	Joint d' étanchéité 32x45x6x5	Ölschutzring 32x45x6x5	Reté n de aceite 32x45x6x5
25	10.66620.000	1		Anello or 25,12x1,78	O-Ring 25,12x1,78	Bague d' étanchéité 25,12x1,78	O-Ring 25,12x1,78	Anillo OR 25,12x1,78
26	006.04.040.00.00	1		Distanziale	Spacer	Entretoise	Distanzstück	Distanciator
27	006.04.050.00.00	1	Z13	Pignone	Pinion	Pignon	Ritzel	Piñón
27	006.04.052.00.00	1	Z15	Pignone	Pinion	Pignon	Ritzel	Piñón
28	006.04.041.00.00	1		Rondella	Washer	Rondelle	U.Scheibe	Arandela
29	006.04.042.00.00	1		Vite M10x18	Screw M10x18	Vis M10x18	Schraube M10x18	Tornillo M10x18
30	006.01.016.00.00	2		Piastrina fissaggio cuscinetto	Fixing bearing plate	Plaque fixe roulement	Plättchen	Placa fij. cojinete
31	C24.90.002.00.00	2		Vite Torx M6x12 10.9/12.9	Screw Torx M6x12 10.9/12.9	Vis Torx M6x12 10.9/12.9	Schraube Torx M6x12 10.9/12.9	Tornillo Torx M6x12 10.9/12.9
32	006.04.000.80.00	1		Cambio completo	Transmission, assy	Boîte de vitesses	Getriebe komplett	Cambio completo

Tav.05

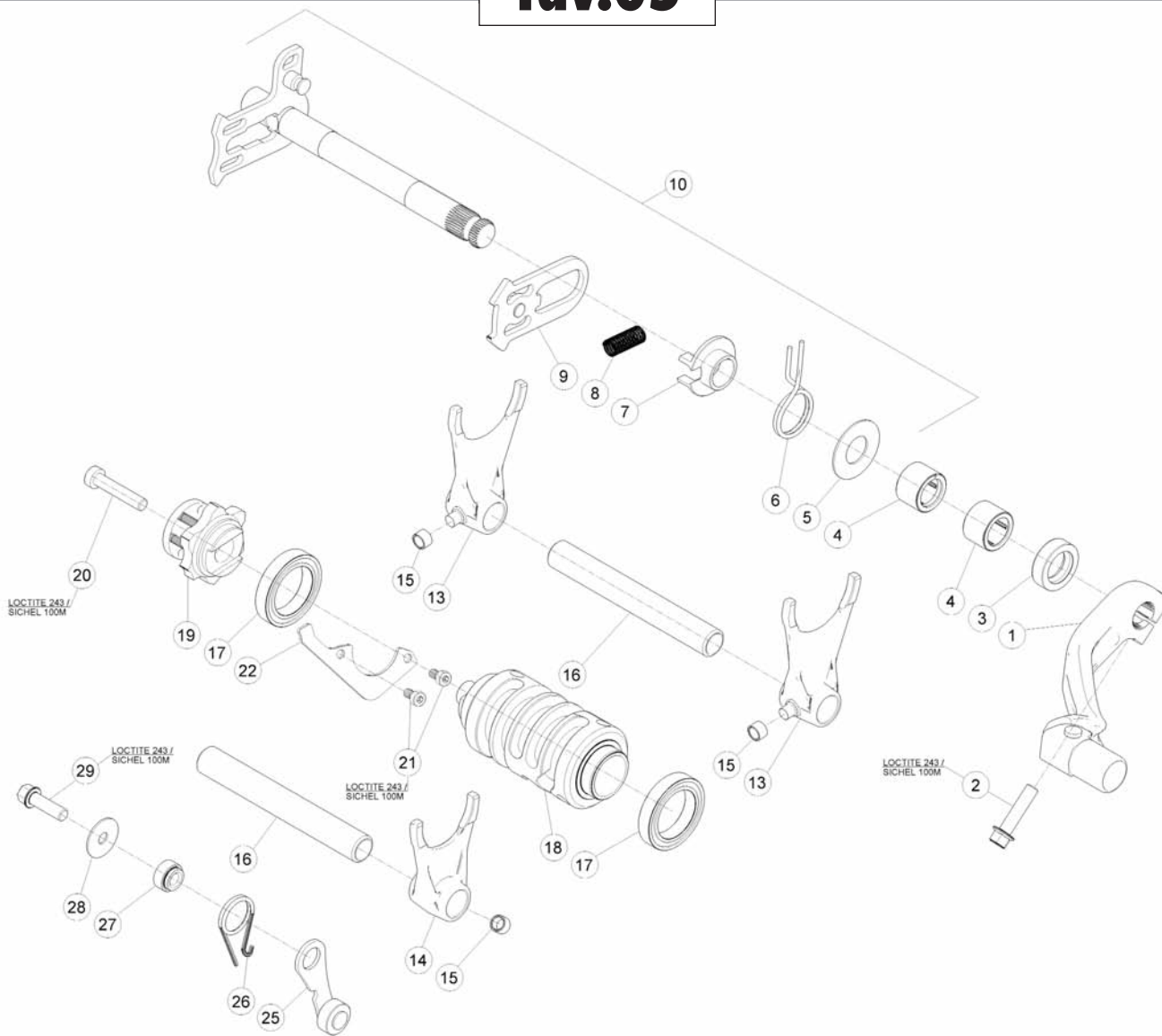

Pos Loc Pos Ps Pos	Numero Number Numéro Número Nummer	Q.tà Q.ty Q.té M.ge C.ad	Nota Note Note Nota Anm.	Descrizione	Description	Désignation	Beschreibung	Descripción
1	006.05.000.80.00	1		Leva cambio	Gear change lever	Levier comm. chang. vit.	Schalthebel	Palanca cambio
2	11.50010.000	1		Bullone M6x25	Bolt M6x25	Boulon M6x25	Bolzen M6x25	Tornillo M6x25
3	10.52012.000	1		Anello paraolio 14x24.6	Oil seal 14x24.6	Joint d' é tanché ité 14x24.6	Ölschutzring 14x24.6	Retén de aceite 14x24.6
4	11.22320.000	2		Boccola a rulli	Roller bearing	Douille à roulements	Rollenbuchse	Caja de grasa de rodillos
5	27.63020.000	1		Rondella rasamento 14x30x1	Thrust washer 14x30x1	Rondelle de buté e 14x30x1	Anlaufscheibe 14x30x1	Arandela distanciadora 14x30x1
6	006.05.017.00.00	1		Molla ritorno comando cambio	Gearchange return spring	R ressort de retour comm. ch.ge vit.	Rückstellfeder schaltung	Muelle de retorno cambio
7	16.92911.000	1		Guida molla	Spring guide	Guide ressort	Federführung	Guida de resorte
8	006.05.016.00.00	1		Molla 0,8MM	Spring 0,8MM	R ressort 0,8MM	Feder 0,8MM	Muelle 0,8MM
9	006.05.014.80.00	1		Ventaglio mobile	Movable pawl	Eventail mobile	Schaltautomat	Abanico mó vil
10	006.05.010.80.00	1		Albero comando cambio completo	Gearshift shaft	Arbre de vitesse	Schaltwelle	Eje mando cambio
13	006.05.020.00.00	2		Forchetta 1/4	Fork 1/4	Fourchette 1/4	Schaltgabel 1/4	Horquilla 1/4
14	006.05.021.00.00	1		Forchetta 5/6	Fork 5/6	Fourchette 5/6	Schaltgabel 5/6	Horquilla 5/6
15	006.05.027.00.00	3		Boccola 6x8.5.2.	Bush 6x8.5.2.	Moyeu 6x8.5.2.	Büchse 6x8.5.2.	Buje 6x8.5.2.
16	026.05.025.00.00	2		Perno forchetta	Spindle, fork	Axe de fourche	Schaltgabelstift	Perno de la horquilla
17	12.93405.000	2		Cuscinetto 61805	Bearing 61805	Roulement 61805	Lager 61805	Cojinete 61805
18	006.05.030.00.00	1		Camma cambio	Selector drum	Barillet de sélection de vitesses	Schaltwalze	Leva de la caja de cambios
19	029.05.001.80.00	1		Camma Arresto Marce	Gear Stopper Cam	Came Buté e Vitesses	Gangsperrnocken	Leva Parada Marchas
20	31.45115.000	1		Vite M6X30	Screw M6X30	Vis M6X30	Schraube M6X30	Tornillo M6X30
21	C24.24.045.00.00	2		Vite a brugola TCCE 5x10	Allen screw TCCE 5x10	Vis à 6 pans TCCE 5x10	Sechskantschraube TCCE 5x10	Tornillo a llave allen TCCE 5x10
22	029.05.031.00.00	1		Piastrina fissaggio cuscinetto	Fixing bearing plate	Plaquette fix. roulement	Plättchen	Placa fij. cojinete
25	029.05.050.80.00	1		Leva arresto marce	Gear stop lever	Levier arré t vit.	Gangstopphebel	Palanca arresto vel.
26	22.39591.000	1		Molla arresto marce	Gear stop spring	R ressort arré t vit.	Gangstopffeder	Muelle arresto vel.
27	029.05.054.00.00	1		Distanziale	Spacer	Entretoise	Distanzstück	Distanciador
28	27.42000.100	1		Rondella 6x20.1,0	Washer 6x20.1,0	Rondelle 6x20.1,0	U.Scheibe 6x20.1,0	Arandela 6x20.1,0
29	31.30780.000	1		Vite TBIB M6x20	Screw TBIB M6x20	Vis TBIB M6x20	Schraube TBIB M6x20	Tornillo TBIB M6x20

Tav.07

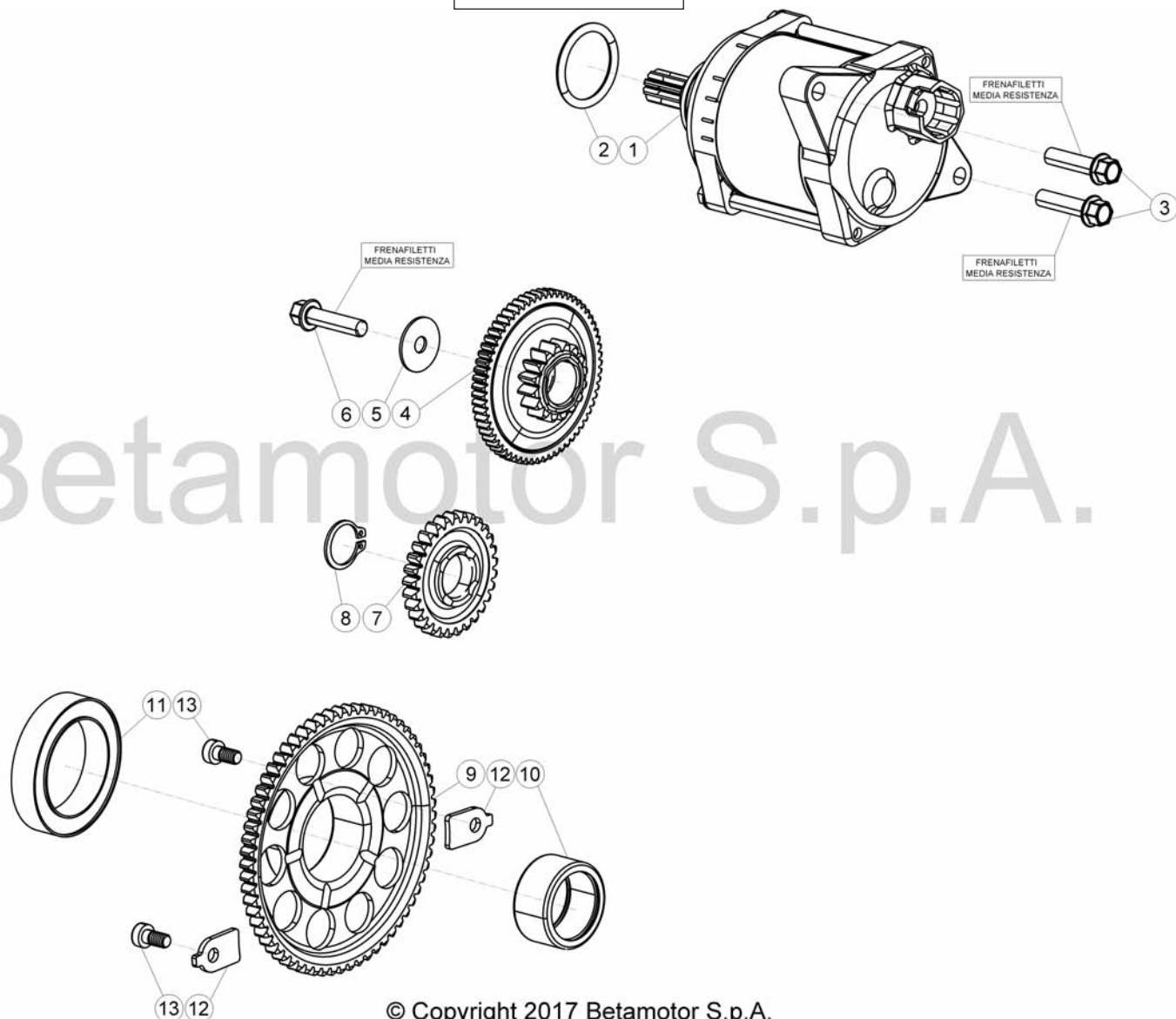

© Copyright 2017 Betamotor S.p.A.

Pos	Numero	Q.tà	Nota	Descrizione	Description	Dé signation	Beschreibung	Descripciò n
Loc	Number	Q.ty	Note					
Pos	Numé ro	Q.té	Note					
Ps	Nú mero	M.ge	Nota					
Pos	Nummer	C.ad	Anm.					
1	029.07.000.80.00	1		Motorino avviamento 0,45KW	Starter motor 0,45KW	Moteur du démarreur 0,45KW	Startermotor 0,45KW	Motor de arranque 0,45KW
2	36.25056.000	1		Anello OR 25,00x3,00	O-Ring 25,00x3,00	Bague d' é tanché ité 25,00x3,00	O-Ring 25,00x3,00	Anillo OR 25,00x3,00
3	11.50010.000	2		Bullone 6x25 ch8 rs	Bolt 6x25 ch8 rs	Boulon 6x25 ch8 rs	Bolzen 6x25 ch8 rs	Tornillo 6x25 ch8 rs
4	029.07.010.80.00	1		Limitatore di coppia	Torque limiting	Limiteur de coupe	Drehmomentbegrenzer - Gefü hrte Puffer	Limitador de par de torsion
5	27.42000.100	1		Rondella spessore 6.20.1	Spacer washer 6.20.1	Entretoise 6.20.1	Distanzscheibe 6.20.1	Arandela distanciadora 6.20.1
6	11.50010.000	1		Bullone M6x25	Bolt M6x25	Boulon M6x25	Bolzen M6x25	Tornillo M6x25
7	029.07.020.00.00	1		Ingranaggio ozioso	Idle gear	Engrenage parasite	Zahnrad	Engranaje parásita
8	28.24460.000	1		Seeger 16x1	Circlip 16x1	Circlip 16x1	Seeger 16x1	Seeger 16x1
9	029.07.030.00.00	1		Ingranaggio avviamento	Starter gear	Engrenage du démarreur	Starterzahnrad	Engranaje puesta en marcha
10	006.07.031.00.00	1		Boccola a rulli HK 2516	Roller bearing HK 2516	Douille à roulements HK 2516	Rollenbuchse HK 2516	Caja de grasa de rodillos HK 2516
11	006.07.040.00.00	1		Ruota libera	Free wheel	Roue libre	Freilauf	Rueda libre
12	029.07.025.00.00	2		Piastrina ingranaggio avviamento	Starter gear plate	Plaquette engrenage du démarreur	Plättchen starterzahnrad	Placa engranaje puesta en marcha
13	C24.24.045.00.00	2		Vite a brugola TCCE 5x10	Allen screw TCCE 5x10	Vis à 6 pans TCCE 5x10	Sechskantschraube TCCE 5x10	Tornillo a llave allen TCCE 5x10

Tav.08

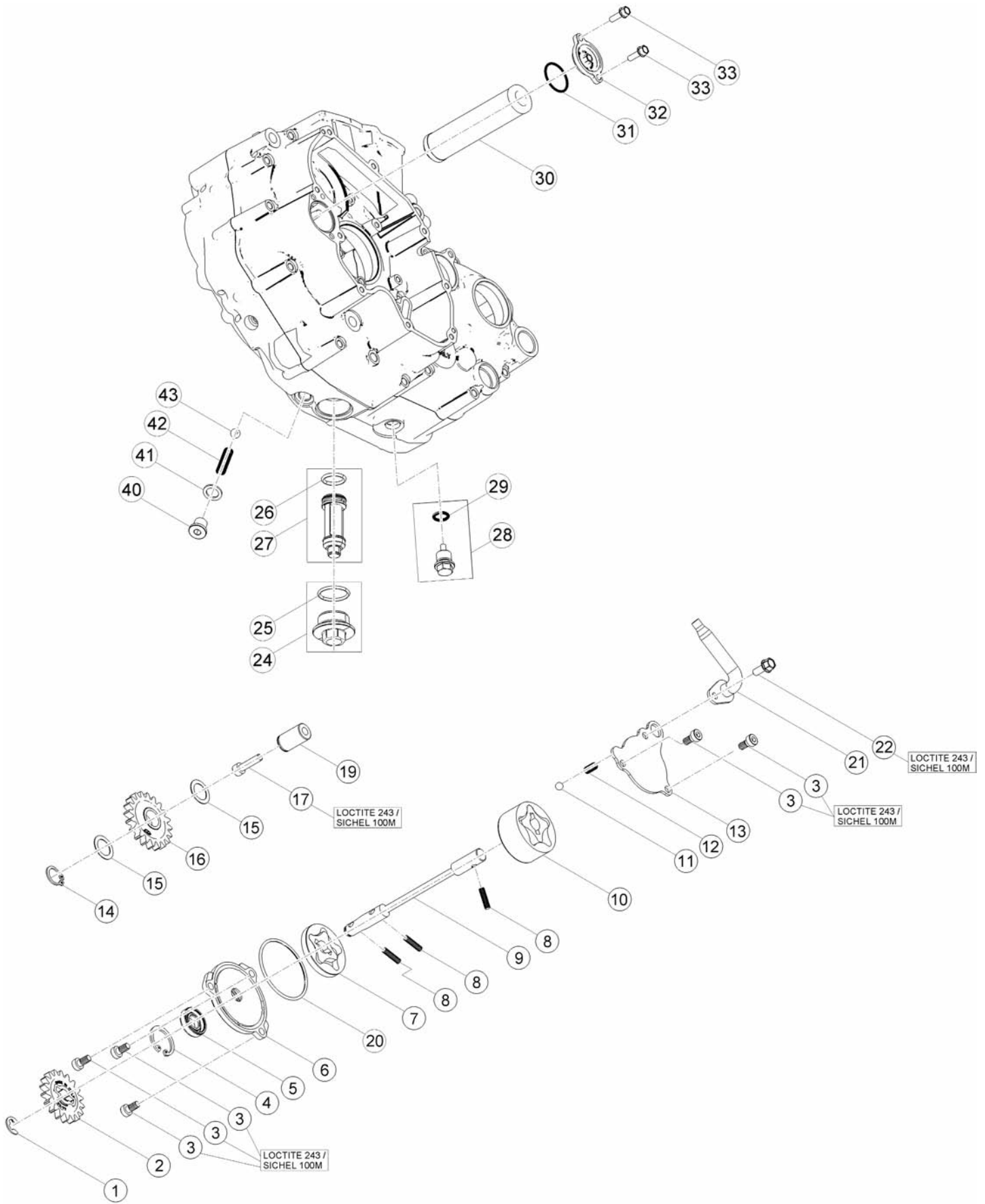

Tav.08

Pos Loc Ps Pos	Numero Number Numéro Nummer	Q.tà Q.ty Q.té M.ge C.ad	Nota Note Nota Anm.	Descrizione	Description	Dé signation	Beschreibung	Descrìpziò n
1	28.22645.000	1		Seeger RA 7	Circlip RA 7	Circlip RA 7	Seeger RA 7	Seeger RA 7
2	006.08.022.00.00	1		Ingranaggio pompa olio	Oil pump gear	Engrenage pompe huile	Zahnrad Ölpumpe	Engranaje bomba aceite
3	C24.24.045.00.00	5		Vite a brugola TCCE 5x10	Allen screw TCCE 5x10	Vis à 6 pans TCCE 5x10	Sechskantschraube TCCE 5x10	Tornillo a llave allen TCCE 5x10
4	28.25502.000	1		Seeger JS24	Circlip JS24	Circlip JS24	Seeger JS24	Seeger JS24
5	10.44695.000	1		Anello paraolio 10x22.6	Oil seal 10x22.6	Joint d' é tanché ité 10x22.6	Ölschutzring 10x22.6	Retén de aceite 10x22.6
6	029.08.011.00.00	1		Coperchio pompa olio pressione	Oil perssure pump cover	Couvercle pompe à huile refoulement	Deckel Druckölpumpe	Tapa bomba aceite mandata
7	006.08.010.80.00	1		Pompa olio D=40,56 B=5	Oil pump D=40,56 B=5	Pompe huile D=40,56 B=5	Ölpumpe D=40,56 B=5	Bomba aceite D=40,56 B=5
8	12.93384.000	3		Rullino 4x15,8	Roller 4x15,8	Rouleau 4x15,8	Rolle 4x15,8	Rodillo 4x15,8
9	006.08.120.00.00	1		Albero pompa olio	Oil punp shaft	Arbre de pompe à huile	Ölpumpenwelle	Eje bomba aceite
10	006.08.000.80.00	1		Pompa olio D=40,56 B=19	Oil pump D=40,56 B=19	Pompe huile D=40,56 B=19	Ölpumpe D=40,56 B=19	Bomba aceite D=40,56 B=19
11	28.90220.000	1		Sfera Dx5,5	Ball Dx5,5	Bille Dx5,5	Kugel Dx5,5	Bola Dx5,5
12	006.08.041.00.00	1		Molla	Spring	Ressort	Feder	Muelle
13	029.08.010.00.00	1		Coperchio pompa olio aspirazione	Oil intake pump cover	Couvercle pompe à huile aspiration	Deckel Ölsaugpumpe	Tapa bomba aceite aspiraciò n
14	28.22810.000	1		Seeger A13	Circlip A13	Circlip A13	Seeger A13	Seeger A13
15	27.61395.050	2		Rondella spessoramento 13x19,0,50	Spacer washer 13x19,0,50	Entretoise 13x19,0,50	Distanzscheibe 13x19,0,50	Arandela distanciadora 13x19,0,50
16	029.08.030.00.00	1		Rinvio ingranaggio pompa olio	Oil pump gear	Renvoi engrenage pompe huile	Zahnrad Ölpumpe	Reenví o engranaje bomba aceite
17	31.30015.000	1		Vite a brugola 5x20	Allen screw 5x20	Vis à 6 pans 5x20	Sechskantschraube 5x20	Tornillo a llave allen 5x20
19	006.08.032.00.00	1		Perno	Pin	Pivot	Zapfen	Perno
20	10.66934.000	1		Anello OR 45 x 2	O-Ring 45 x 2	Bague d' é tanché ité 45 x 2	O-Ring 45 x 2	Anillo OR 45 x 2
21	029.08.002.80.00	1		Raccordo tubo olio	Oil channel joint	Raccord tuyau huile	Ölschlauchanschluß	Racor tubo aceite
22	11.46251.000	1		Bullone flangiato M5x12	Head Flanged bolt M5x12	Boulon Bridé M5x12	Bundbolzen M5x12	Bulón con Brida M5x12
24	029.08.050.80.00	1		Tappo scarico olio	Oil exh. plug	Bouchon dech. huile	Ölablassschraube	Tapón de descarga aceite
25	10.66321.000	1		Anello OR 17,17x1,78	O-Ring 17,17x1,78	Bague d' é tanché ité 17,17x1,78	O-Ring 17,17x1,78	Anillo OR 17,17x1,78
26	10.66168.000	1		Anello OR 12x2	O-Ring 12x2	Bague d' é tanché ité 12x2	O-Ring 12x2	Anillo OR 12x2
27	029.08.051.80.00	1		Filtro olio	Oil filter	Filtre à huile	Ölfilter	Filtro de aceite
28	006.08.152.80.00	1		Tappo scarico olio	Oil exh. plug	Bouchon dech. huile	Ölablassschraube	Tapón de descarga aceite
29	10.66164.000	1		Anello Or 11x2,5 nbr70 sh	O-Ring 11x2,5 nbr70 sh	Bague d' é tanché ité 11x2,5 nbr70 sh	O-Ring 11x2,5 nbr70 sh	Anillo OR 11x2,5 nbr70 sh
30	006.08.070.00.00	1		Filtro olio	Oil filter	Filtre à huile	Ölfilter	Filtro de aceite
31	10.66685.000	1		Anello OR 28,1,5 VITON	O-Ring 28,1,5 VITON	Bague d' é tanché ité 28,1,5 VITON	O-Ring 28,1,5 VITON	Anillo OR 28,1,5 VITON
32	029.08.060.00.00	1		Tappo filtro olio	Oil filter plug	Bouchon filtre huile	Ölfilterverschluss	Tapa filtro aceite
33	11.48025.000	2		Bullone 6x16 ch 8 rs	Bolt 6x16 ch 8 rs	Boulon 6x16 ch 8 rs	Bolzen 6x16 ch 8 rs	Tornillo 6x16 ch 8 rs
40	36.25062.000	2		Tappo M12 X 1,5	Plug M12 X 1,5	Bouchon M12 X 1,5	Verschluß M12 X 1,5	Tapón M12 X 1,5
41	27.60265.000	1		Rondella rasamento 12x18x1,5	Thrust washer 12x18x1,5	Rondelle de buté e 12x18x1,5	Anlaufscheibe 12x18x1,5	Arandela distanciadora 12x18x1,5
42	029.08.040.00.00	1		Molla	Spring	Ressort	Feder	Muelle
43	28.90225.000	1		Sfera Dx9	Ball Dx9	Bille Dx9	Kugel Dx9	Bola Dx9

Tav.09

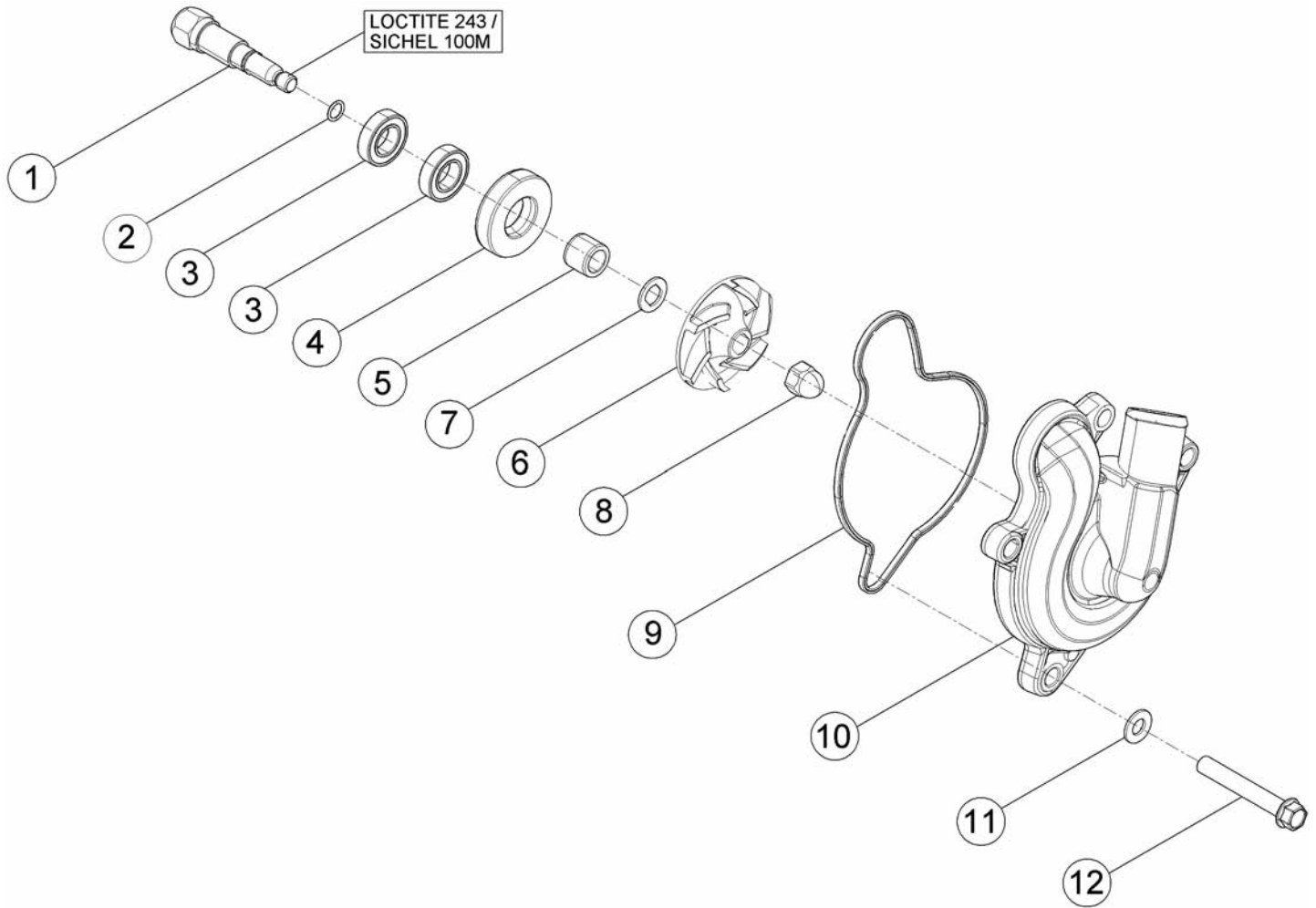

Pos Loc Pos Ps Pos	Numero Number Numéro Número Nummer	Q.tà Q.ty Q.té M.ge C.ad	Nota Note Note Nota Anm.	Descrizione	Description	Dé signation	Beschreibung	Descripció n
1	006.09.010.00.00	1		Albero pompa acqua	Coolant pump shaft	Arbre de pompe a eau	Wasserpumpenwelle	Eje bomba de agua
2	10.66136.000	1		Anello OR 5,5x1	O-Ring 5,5x1	Bague d' é tanché ité 5,5x1	O-Ring 5,5x1	Anillo OR 5,5x1
3	12.93400.000	2		Cuscinetto 10x19.5	Bearing 10x19.5	Roulement 10x19.5	Lager 10x19.5	Cojinete 10x19.5
4	10.48030.000	1		Anello paraolio 12x30.7	Oil seal 12x30.7	Joint d' é tanché ité 12x30.7	Ölschutzring 12x30.7	Retén de aceite 12x30.7
5	006.09.011.00.00	1		Boccola 8x12.10	Bush 8x12.10	Moyeu 8x12.10	Bü chse 8x12.10	Buje 8x12.10
6	006.09.000.00.00	1		Girante pompa	Rotor	Roue de pompe	Wasserpumpenrad	Rotor de la bomba
7	006.09.012.00.00	1		Rondella	Washer	Rondelle	U.Scheibe	Arandela
8	13.11520.000	1		Dado M6X1	Nut M6X1	Ecrou M6X1	Mutter M6X1	Tuerca M6X1
9	006.09.021.00.00	1		Guarnizione pompa acqua	Water pump gasket	Joint pompe eau	Dichtung Wasserpumpe	Empaque bomba agua
10	006.09.020.00.00	1		Coperchio pompa acqua	Water pump cover	Couvercle pompe à eau	Wasserpumpendeckel	Tapa bomba agua
11	27.40490.000	1		Rondella in rame 6x10x2	Copper washer 6x10x2	Rondelle en cuivre 6x10x2	Kupfer U.Scheibe 6x10x2	Arandela de cobre 6x10x2
12	11.50360.000	4		Bullone M6x40	Bolt M6x40	Boulon M6x40	Bolzen M6x40	Tornillo M6x40

Tav.10

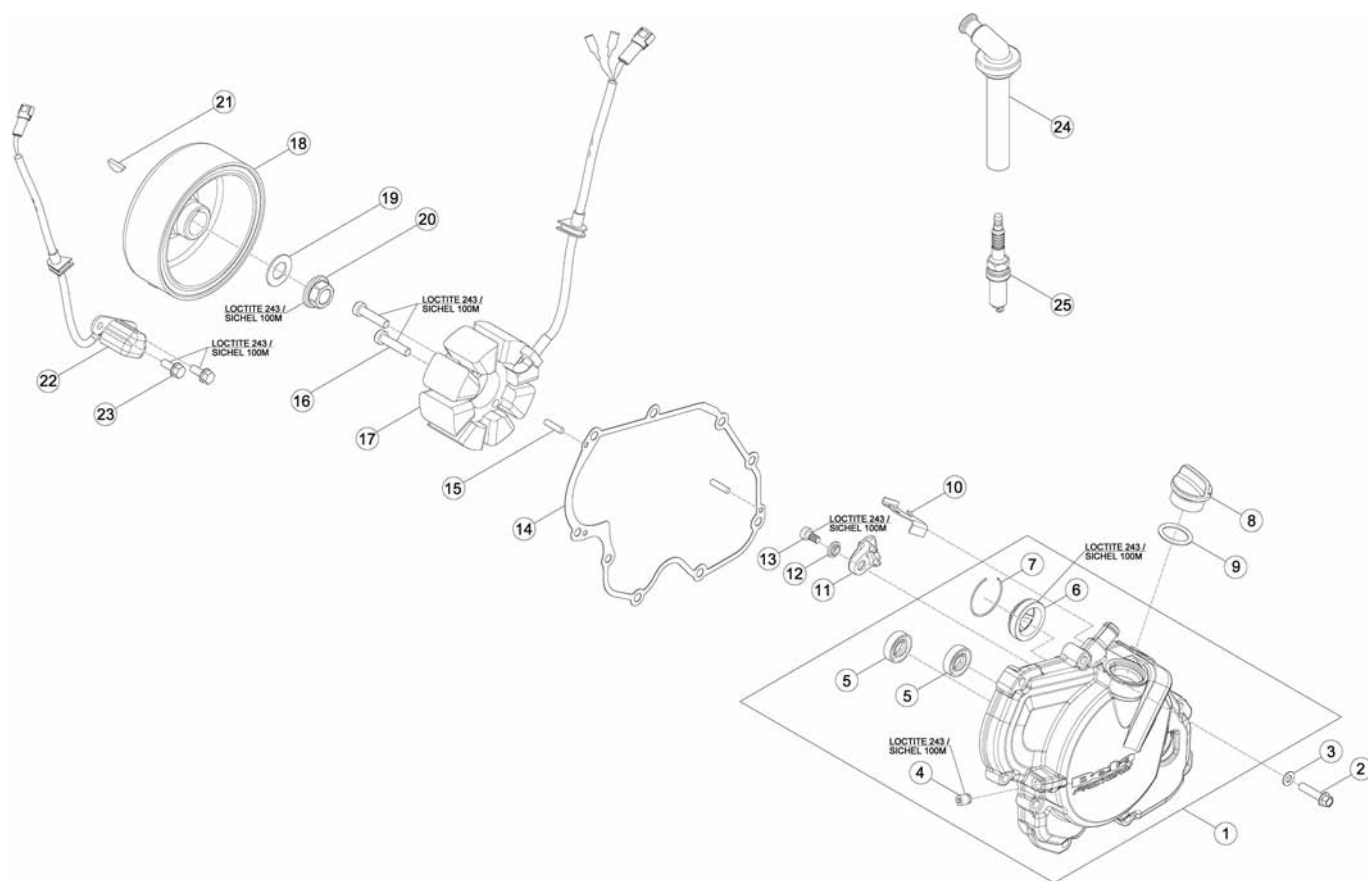

Pos Loc Pos Ps Pos	Numero Number Numé ro Número Nummer	Q.tà Q.ty Q.té M.ge C.ad	Nota Note Note Nota Anm.	Descrizione	Description	Dé signation	Beschreibung	Descrìpiò n
1	027.01.050.80.00	1		Coperchio volante	Flywheel cover	Carter volant	Schwungraddeckel	Tapa volante
2	11.50010.000	9		Bullone M6x25	Bolt M6x25	Boulon M6x25	Bolzen M6x25	Tornillo M6x25
3	27.58000.000	1		Rondella	Washer	Rondelle	U.Scheibe	Arandela
4	006.01.021.00.00	1		Tappo olio ad espansione 7X9	Oil expansion plug 7X9	Bouchon d'huile à expansion 7X9	Öl-expansionsstopfen 7X9	Tapón extensible del aceite 7X9
5	10.44690.000	2		Anello paraolio 10x22.6	Oil seal 10x22.6	Joint d'tanché ité 10x22.6	Ölschutzring 10x22.6	Retén de aceite 10x22.6
6	006.01.056.00.00	1		Oblò ispezione livello olio	Oil level sight glass	Hublot d'inspection niveau huile	Ölkontrollschauglas	Visor de inspección nivel aceite
7	28.25680.000	1		Seeger 30X1	Circlip 30X1	Seeger 30X1	Seeger 30X1	Seeger 30X1
8	29.09601.000	1		Tappo carico olio	Oil filling cap	Bouchon rempl. huile	Öleinfüllstopfen	Tapón introducción n aceite
9	10.66340.000	1		Anello OR 16x3	O-Ring 16x3	Bague d' é tanché ité 16x3	O-Ring 16x3	Anillo OR 16x3
10	006.01.054.00.00	1		Piastrina	Plate	Plaque	Plättchen	Placa
11	006.11.070.00.00	1		Guida catena	Chain guide	Guide chaî ne	Kettenführung	Gui a catena
12	029.08.081.00.00	1		Boccola	Bush	Moyeu	Büchse	Buje
13	C24.24.045.00.00	1		Vite a brugola TCCE 5x10	Allen screw TCCE 5x10	Vis à 6 pans TCCE 5x10	Sechskantschraube TCCE 5x10	Tornillo a llave allen TCCE 5x10
14	006.01.051.00.00	1		Guarnizione coperchio volante	Alternator cover gasket	Garniture couvercle alternateur	Alternatordeckeldichtung	Junta tapa alternador
15	12.93384.000	2		Rullino 4x15,8	Roller 4x15,8	Rouleau 4x15,8	Rolle 4x15,8	Rodillo 4x15,8
16	C24.24.039.00.00	3		Vite a brugola TCCE M5x30	Allen screw TCCE M5x30	Vis à 6 pans TCCE M5x30	Sechskantschraube TCCE M5x30	Tornillo a llave Allen TCCE M5x30
17	006.10.120.00.00	1		Statore	Backplate	Stator	Ankerplatte	Estator
18	006.10.110.00.00	1		Rotore	Rotor	Rotor	Rotor	Rotor
19	27.74810.000	1		Rondella elastica	Spring Washer	Rondelle é lastique	Federring	Arandela elástica
20	13.25010.000	1		Dado M12x1	Nut M12x1	Ecrou M12x1	Mutter M12x1	Tuerca M12x1
21	12.46020.000	1		Chiavetta 3x5	Key 3x5	Clavette 3x5	Keil 3x5	Chaveta 3x5
22	006.10.030.00.00	1		Pick up	Pick-up	Capteur	Pick-up	Pick-up
23	11.46251.000	2		Bullone flangiato M5x12	Head Flanged bolt M5x12	Boulon Bridé M5x12	Bundbolzen M5x12	Bulón con Brida M5x12
24	006.10.055.00.00	1		Cappuccio candela	Spark plug cap	Capuchon/couvercle bougie	Zündkerzenkappe	Capuchón de la bujía
25	006.10.050.00.00	1		Candela M12X1,25	Spark plug M12X1,25	Bougie M12X1,25	Zündkerze M12X1,25	Bujía M12X1,25

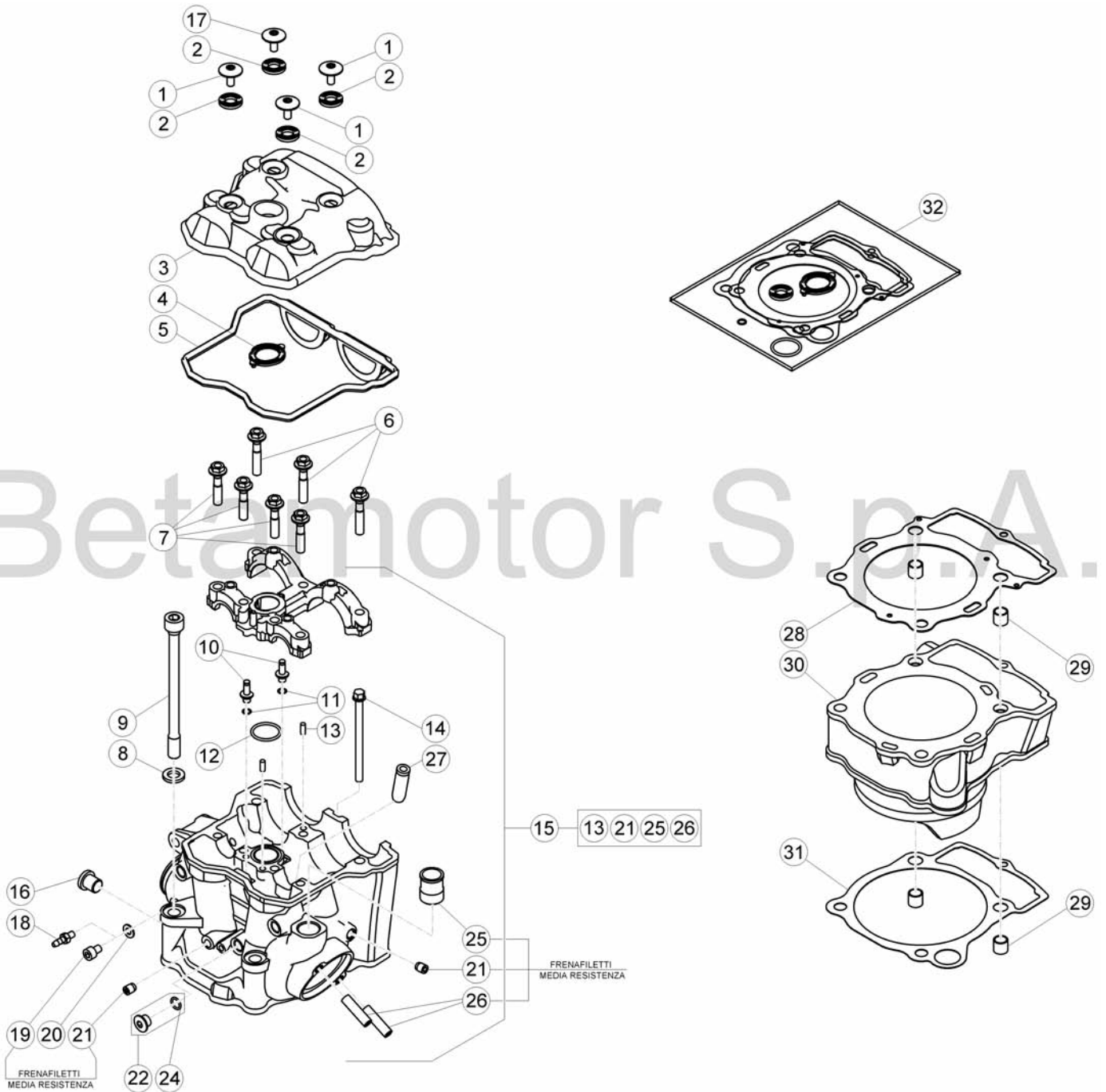

© Copyright 2016 Betamotor S.p.A.

Tav.11

Pos Loc Ps Pos	Numero Number Numéro Nummer	Q.tà Q.ty Q.té M.ge C.ad	Nota Note Note Nota Anm.	Descrizione	Description	Dé signation	Beschreibung	Descrìpziò n
1	006.11.025.00.00	3		Vite coperchio testa	Cylinder head cover screw	Vis couvercle culasse	Schraube Zylinderkopfabdeckung	Tornillo tapa culata
2	006.11.026.00.00	4		Guarnizione	Packing	Joint	Dichtung	Junta
3	006.11.020.00.52	1		Coperchio testa	Cylinder head cover	Couvercle culasse	Zylinderkopfabdeckung	Tapa culata
4	006.11.022.00.00	1		Guarnizione sede candela	Packing spark-plug connector	Joint fiche bougie	Dichtung Kerzenstecker	Junta enchufe para bujia
5	029.11.021.00.00	1		Guarnizione coperchio testa	Cylinder head cover gasket	Joint couvercle culasse	Dichtung Zylinderkopfabdeckung	Junta tapa culata
6	11.52427.000	3		Bullone speciale 7x38	Special bolt 7x38	Boulon spéciale 7x38	Spezialschraube 7x38	Tornillo especial 7x38
7	11.52425.000	4		Bullone speciale 7x33	Special bolt 7x33	Boulon spéciale 7x33	Spezialschraube 7x33	Tornillo especial 7x33
8	006.11.012.00.00	4		Distanziale 10,5X18,5X2,5	Spacer 10,5X18,5X2,5	Entretoise 10,5X18,5X2,5	Distanzstück 10,5X18,5X2,5	Distanciadador 10,5X18,5X2,5
9	022.11.013.00.00	4		Vite M10x1,25 L=127,5	Screw M10x1,25 L=127,5	Vis M10x1,25 L=127,5	Schraube M10x1,25 L=127,5	Tornillo M10x1,25 L=127,5
10	006.11.009.00.00	2		Getto	Jet	Gicleur	Düse	Surtidor
11	10.66136.000	2		Anello OR 5,5x1	O-Ring 5,5x1	Bague d' é tanché ité 5,5x1	O-Ring 5,5x1	Anillo OR 5,5x1
12	10.66495.000	1		Anello OR 22x2	O-Ring 22x2	Bague d' é tanché ité 22x2	O-Ring 22x2	Anillo OR 22x2
13	36.25021.000	2		Rullino 4,0 X 9,8	Roller 4,0 X 9,8	Rouleau 4,0 X 9,8	Rolle 4,0 X 9,8	Rodillo 4,0 X 9,8
14	11.05445.000	1		Bullone 6x80	Bolt 6x80	Boulon 6x80	Bolzen 6x80	Tornillo 6x80
15	028.11.000.80.00	1	350-390cc	Testa completa	Cylinder head	Culasse complete	Zylinderkopf Kpl.	Culata completa
15	029.11.100.80.00	1	430-500cc	Testa completa	Cylinder head	Culasse complete	Zylinderkopf Kpl.	Culata completa
16	029.13.004.00.00	1		Sensore temperatura	Temperature sensor	Capteur de temperature	Wassertemperatursensor	Sensò r temperatura
17	006.11.035.00.00	1		Vite di sicurezza	Tab screw	Vis de sû reté	Sicherungs-Schraube	Tornillo de seguridad
18	29.00280.000	1		Raccordo	Joint	Raccord	Stützen	Racor
19	C24.24.044.00.00	1		Vite a brugola TCCE 6.8	Allen screw TCCE 6.8	Vis à 6 pans TCCE 6.8	Sechskantschraube TCCE 6.8	Tornillo a llave allen TCCE 6.8
20	27.58000.000	1		Rondella	Washer	Rondelle	U.Scheibe	Arandela
21	006.01.021.00.00	2		Tappo olio ad espansione 7X9	Oil expansion plug 7X9	Bouchon d' huile à expansion 7X9	Öl-expansionsstopfen 7X9	Tapò n extensible del aceite 7X9
22	006.11.045.80.00	1		Tappo Albero coperchio frizione	Clutch cover Arm Plug	Bouchon Arbre Couvercle d' embrayage	Endkappe Kupplungsdeckel	Tapa Ciguenal embrague
24	10.50010.000	1		Anello OR 8x1,5x	O-Ring 8x1,5x	Bague d' é tanché ité 8x1,5x	O-Ring 8x1,5x	Anillo OR 8x1,5x
25	006.11.108.00.00	1		Raccordo uscita acqua M20x1,25	Water outlet union M20x1,25	Raccord é vacuation d' eau M20x1,25	Anschluß für Wasserblauf M20x1,25	Conexiò n salida agua M20x1,25
26	006.11.019.00.00	2		Prigioniero M8X30	Stud M8X30	Goujon M8X30	Stiftschraube M8X30	Espá rrago M8X30
27	006.11.005.00.00	4		Guida valvola	Valve guide	Guide soupape	Ventilführung	Gui a válvula
28	027.02.063.00.00	1	350-390cc	Guarnizione testa ø88	Cylinder head gasket ø88	Joint Culasse ø88	Zylinderkopfdichtung ø88	Junta de culata ø88
28	029.02.063.00.00	1	430cc	Guarnizione testa	Cylinder head gasket	Joint Culasse	Zylinderkopfdichtung	Junta de culata
28	030.02.063.00.00	1	500cc	Guarnizione testa	Cylinder head gasket	Joint Culasse	Zylinderkopfdichtung	Junta de culata
29	006.02.070.00.00	4		Boccola 10,5x12x11	Bush 10,5x12x11	Moyeu 10,5x12x11	Bü chse 10,5x12x11	Buje 10,5x12x11
30	027.02.060.00.01	1	350-390cc	Cilindro ø88 Misura 1	Cylinder ø88 Size 1	Cylindre ø88 Mesure 1	Zylinder ø88 Typ 1	Cilindro ø88 Medida 1
30	027.02.060.00.02	1	350-390cc	Cilindro ø88 Misura 2	Cylinder ø88 Size 2	Cylindre ø88 Mesure 2	Zylinder ø88 Typ 2	Cilindro ø88 Medida 2
30	029.02.060.00.01	1	430cc	Cilindro 1M	Cylinder 1M	Cylindre 1M	Zylinder 1M	Cilindro 1M
30	029.02.060.00.02	1	430cc	Cilindro 2M	Cylinder 2M	Cylindre 2M	Zylinder 2M	Cilindro 2M
30	030.02.060.00.01	1	500cc	Cilindro 1M	Cylinder 1M	Cylindre 1M	Zylinder 1M	Cilindro 1M
30	030.02.060.00.02	1	500cc	Cilindro 2M	Cylinder 2M	Cylindre 2M	Zylinder 2M	Cilindro 2M
31	027.02.062.00.00	1	350-390cc	Guarnizione base cilindro 0,5mm	Cylinder base gasket 0,5mm	Garniture base cylindre 0,5mm	Dichtung für Zylinderfuß 0,5mm	Junta base cilindro 0,5mm
31	029.02.162.00.00	1	430cc	Guarnizione base cilindro 0,3MM	Cylinder base gasket 0,3MM	Garniture base cylindre 0,3MM	Dichtung für Zylinderfuß 0,3MM	Junta base cilindro 0,3MM
31	029.02.162.00.00	2	500cc	Guarnizione base cilindro 0,3MM	Cylinder base gasket 0,3MM	Garniture base cylindre 0,3MM	Dichtung für Zylinderfuß 0,3MM	Junta base cilindro 0,3MM
32	027.11.010.82.00	1	350-390cc	Busta guarnizioni cilindro-testa	Head-cylinder gaskets set	Etui garnitures cylindre-tête	Beutel mit Zylinderkopfdichtungen	Serie juntas cilindro culata
32	029.11.067.82.00	1	430cc	Busta guarnizioni cilindro-testa	Head-cylinder gaskets set	Etui garnitures cylindre-tête	Beutel mit Zylinderkopfdichtungen	Serie juntas cilindro culata
32	030.11.000.82.00	1	500cc	Busta guarnizioni cilindro-testa	Head-cylinder gaskets set	Etui garnitures cylindre-tête	Beutel mit Zylinderkopfdichtungen	Serie juntas cilindro culata

Tav.11A

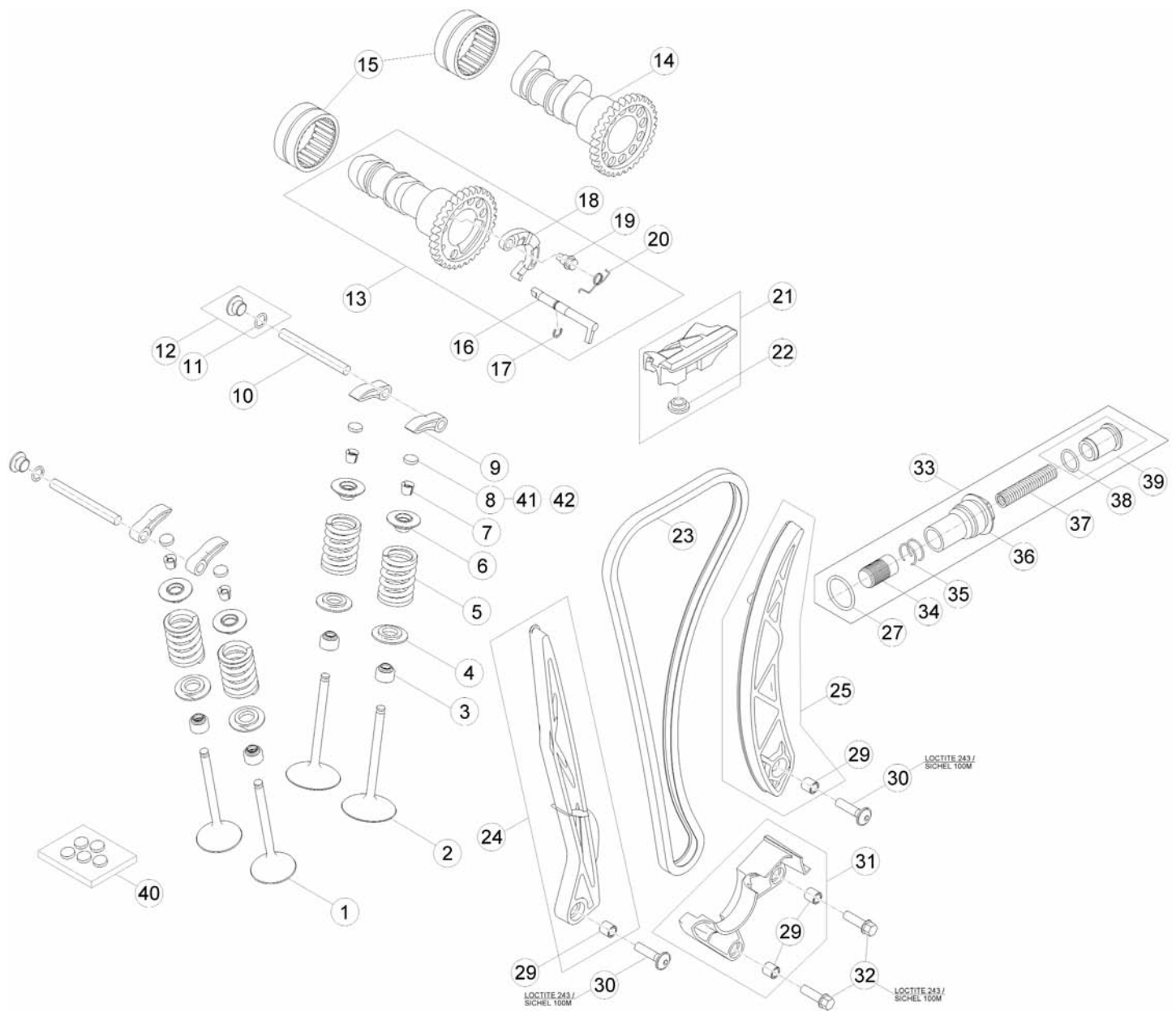

Tav.11A

Pos Loc Pos Ps Pos	Numero Number Numéro Nummer	Q.tà Q.ty Q.té M.ge C.ad	Nota Note Note Nota Anm.	Descrizione	Description	Dé signation	Beschreibung	Descrìpziò n
1	027.11.033.00.00	2	350-390cc	Valvola scarico	Exhaust valve	Soupape d' é ch.	Auslaßventil	Válvula de escape
1	029.11.003.00.00	2	430-500cc	Valvola scarico	Exhaust valve	Soupape d' é ch.	Auslaßventil	Válvula de escape
2	027.11.032.00.00	2	350-390cc	Valvola aspirazione	Suction valve	Soupape aspir.	Einlaßventil	Válvula aspiració n
2	029.15.032.00.00	2	430-500cc	Valvola aspirazione	Suction valve	Soupape aspir.	Einlaßventil	Válvula aspiració n
3	006.11.139.00.00	4		Gambo Valvole	Gambo Valves	Tige Valves	Ventilschaftdichtung	Brazo Valvulas
4	027.11.037.00.00	4		Scodellino inferiore	Lower stop washer	Rondelle d' arrê t infê rieur	Unterer Federaufnahme	Platillo inferior
5	027.11.034.00.00	4		Molla valvola	Valve spring	Ressort soupape	Ventilfeder	Muelle válvula
6	027.11.036.00.00	4		Scodellino superiore	Upper stop washer	Rondelle d' arrê t supê rieur	Oberer Federaufnahme	Platillo superior
7	006.11.038.00.00	8		Semicono	Cone, half	Demi bague	Buchse halb	Semicasquillo
8	006.11.040.20.00	1		Rondella spessore 2,000	Shim 2,000	Rondelle entretoise 2,000	Ausgleichscheib 2,000	Arandela suplemento 2,000
8	006.11.040.20.05	1		Rondella spessore 2,050	Shim 2,050	Rondelle entretoise 2,050	Ausgleichscheib 2,050	Arandela suplemento 2,050
8	006.11.040.20.10	1		Rondella spessore 2,100	Shim 2,100	Rondelle entretoise 2,100	Ausgleichscheib 2,100	Arandela suplemento 2,100
8	006.11.040.20.15	1		Rondella spessore 2,150	Shim 2,150	Rondelle entretoise 2,150	Ausgleichscheib 2,150	Arandela suplemento 2,150
8	006.11.040.20.20	1		Rondella spessore 2,200	Shim 2,200	Rondelle entretoise 2,200	Ausgleichscheib 2,200	Arandela suplemento 2,200
8	006.11.040.20.25	1		Rondella spessore 2,250	Shim 2,250	Rondelle entretoise 2,250	Ausgleichscheib 2,250	Arandela suplemento 2,250
8	006.11.040.20.30	1		Rondella spessore 2,300	Shim 2,300	Rondelle entretoise 2,300	Ausgleichscheib 2,300	Arandela suplemento 2,300
8	006.11.040.20.32	1		Rondella spessore 2,325	Shim 2,325	Rondelle entretoise 2,325	Ausgleichscheib 2,325	Arandela suplemento 2,325
8	006.11.040.20.35	1		Rondella spessore 2,350	Shim 2,350	Rondelle entretoise 2,350	Ausgleichscheib 2,350	Arandela suplemento 2,350
8	006.11.040.20.37	1		Rondella spessore 2,375	Shim 2,375	Rondelle entretoise 2,375	Ausgleichscheib 2,375	Arandela suplemento 2,375
8	006.11.040.20.40	1		Rondella spessore 2,400	Shim 2,400	Rondelle entretoise 2,400	Ausgleichscheib 2,400	Arandela suplemento 2,400
8	006.11.040.20.42	1		Rondella spessore 2,425	Shim 2,425	Rondelle entretoise 2,425	Ausgleichscheib 2,425	Arandela suplemento 2,425
8	006.11.040.20.45	1		Rondella spessore 2,450	Shim 2,450	Rondelle entretoise 2,450	Ausgleichscheib 2,450	Arandela suplemento 2,450
8	006.11.040.20.47	1		Rondella spessore 2,475	Shim 2,475	Rondelle entretoise 2,475	Ausgleichscheib 2,475	Arandela suplemento 2,475
8	006.11.040.20.50	1		Rondella spessore 2,500	Shim 2,500	Rondelle entretoise 2,500	Ausgleichscheib 2,500	Arandela suplemento 2,500
8	006.11.040.20.52	1		Rondella spessore 2,525	Shim 2,525	Rondelle entretoise 2,525	Ausgleichscheib 2,525	Arandela suplemento 2,525
8	006.11.040.20.55	1		Rondella spessore 2,550	Shim 2,550	Rondelle entretoise 2,550	Ausgleichscheib 2,550	Arandela suplemento 2,550
8	006.11.040.20.57	1		Rondella spessore 2,575	Shim 2,575	Rondelle entretoise 2,575	Ausgleichscheib 2,575	Arandela suplemento 2,575
8	006.11.040.20.60	1		Rondella spessore 2,600	Shim 2,600	Rondelle entretoise 2,600	Ausgleichscheib 2,600	Arandela suplemento 2,600
8	006.11.040.20.62	1		Rondella spessore 2,625	Shim 2,625	Rondelle entretoise 2,625	Ausgleichscheib 2,625	Arandela suplemento 2,625
8	006.11.040.20.65	1		Rondella spessore 2,650	Shim 2,650	Rondelle entretoise 2,650	Ausgleichscheib 2,650	Arandela suplemento 2,650
8	006.11.040.20.67	1		Rondella spessore 2,675	Shim 2,675	Rondelle entretoise 2,675	Ausgleichscheib 2,675	Arandela suplemento 2,675
8	006.11.040.20.70	1		Rondella spessore 2,700	Shim 2,700	Rondelle entretoise 2,700	Ausgleichscheib 2,700	Arandela suplemento 2,700
8	006.11.040.20.72	1		Rondella spessore 2,725	Shim 2,725	Rondelle entretoise 2,725	Ausgleichscheib 2,725	Arandela suplemento 2,725
8	006.11.040.20.75	1		Rondella spessore 2,750	Shim 2,750	Rondelle entretoise 2,750	Ausgleichscheib 2,750	Arandela suplemento 2,750
8	006.11.040.20.77	1		Rondella spessore 2,775	Shim 2,775	Rondelle entretoise 2,775	Ausgleichscheib 2,775	Arandela suplemento 2,775
8	006.11.040.20.80	1		Rondella spessore 2,800	Shim 2,800	Rondelle entretoise 2,800	Ausgleichscheib 2,800	Arandela suplemento 2,800
8	006.11.040.20.82	1		Rondella spessore 2,825	Shim 2,825	Rondelle entretoise 2,825	Ausgleichscheib 2,825	Arandela suplemento 2,825
8	006.11.040.20.85	1		Rondella spessore 2,850	Shim 2,850	Rondelle entretoise 2,850	Ausgleichscheib 2,850	Arandela suplemento 2,850
8	006.11.040.20.87	1		Rondella spessore 2,875	Shim 2,875	Rondelle entretoise 2,875	Ausgleichscheib 2,875	Arandela suplemento 2,875
8	006.11.040.20.90	1		Rondella spessore 2,900	Shim 2,900	Rondelle entretoise 2,900	Ausgleichscheib 2,900	Arandela suplemento 2,900
8	006.11.040.20.92	1		Rondella spessore 2,925	Shim 2,925	Rondelle entretoise 2,925	Ausgleichscheib 2,925	Arandela suplemento 2,925
8	006.11.040.20.95	1		Rondella spessore 2,950	Shim 2,950	Rondelle entretoise 2,950	Ausgleichscheib 2,950	Arandela suplemento 2,950
8	006.11.040.20.97	1		Rondella spessore 2,975	Shim 2,975	Rondelle entretoise 2,975	Ausgleichscheib 2,975	Arandela suplemento 2,975
8	006.11.040.30.00	1		Rondella spessore 3,000	Shim 3,000	Rondelle entretoise 3,000	Ausgleichscheib 3,000	Arandela suplemento 3,000
8	006.11.040.30.05	1		Rondella spessore 3,050	Shim 3,050	Rondelle entretoise 3,050	Ausgleichscheib 3,050	Arandela suplemento 3,050
8	006.11.040.30.10	1		Rondella spessore 3,100	Shim 3,100	Rondelle entretoise 3,100	Ausgleichscheib 3,100	Arandela suplemento 3,100
8	006.11.040.30.15	1		Rondella spessore 3,150	Shim 3,150	Rondelle entretoise 3,150	Ausgleichscheib 3,150	Arandela suplemento 3,150
8	006.11.040.30.20	1		Rondella spessore 3,200	Shim 3,200	Rondelle entretoise 3,200	Ausgleichscheib 3,200	Arandela suplemento 3,200
9	006.11.030.00.00	4		Bilanciere	Lever	Balancier	Kipphebel	Balancin
10	006.11.031.00.00	2		Perno bilanciare	Rocker shaft	Axe culbuteur	Kipphebel-Federwelle	Eje balanci n
11	10.50010.000	3		Anello OR 8x1,5x	O-Ring 8x1,5x	Bague d' é tanché ité 8x1,5x	O-Ring 8x1,5x	Anillo OR 8x1,5x
12	006.11.045.80.00	2		Tappo olio	Oil plug	Bouchon huile	Öleinfüllschraube	Tapó n aceite
13	027.11.151.80.00	1	350-390cc	Albero a camme SCARICO	Camshaft EXHAUST	Arbre distr. ECHAPPEMENT	Nockenwelle AUSPUFFSEITE	Eje distribució n DESCARGA
13	029.11.151.80.00	1	430cc	Albero a camme SCARICO	Camshaft EXHAUST	Arbre distr. ECHAPPEMENT	Nockenwelle AUSPUFFSEITE	Eje distribució n DESCARGA
13	029.11.051.80.00	1	500cc	Albero a camme SCARICO	Camshaft EXHAUST	Arbre distr. ECHAPPEMENT	Nockenwelle AUSPUFFSEITE	Eje distribució n DESCARGA
14	029.11.150.00.00	1	350-390cc	Albero a camme ASPIRAZIONE	Camshaft INTAKE	Arbre distribution ADMISSION	Nockenwelle ANSAUGSEITE	Eje distribució n ASPIRACIÓ N
14	006.11.150.00.00	1	430cc	Albero a camme ASPIRAZIONE	Camshaft INTAKE	Arbre distribution ADMISSION	Nockenwelle ANSAUGSEITE	Eje distribució n ASPIRACIÓ N
15	006.11.053.00.00	2		Cuscinetto a rulli	Roller bearing	Roulé ment à aiguilles	Rollenlager	Cojinete de rodillos
16	006.11.156.00.00	1		Albero Di Decompressione	Decompression Shaft	Arbre Decompression	Dekowelle	Ciguenal De Decompression
17	28.22635.000	1		Seeger H7	Circlip H7	Circlip H7	Seeger H7	Seeger H7
18	006.11.155.00.00	1		Massa decompressore	Decompressor weight	Masse dé compression	Masse dekompressor	Masa de descompresió n
19	006.11.057.00.00	1		Perno	Pin	Pivot	Zapfen	Perno
20	029.11.058.00.00	1		Molla decompressione	Decompression spring	Ressort dé compresseur	Dekompressionsfeder	Muelle, descompresió n
21	006.11.063.80.00	1		Pattino fisso	Fixed pad	Patin fixe	Fester Laufschuh	Patí n fijo

Tav.11A

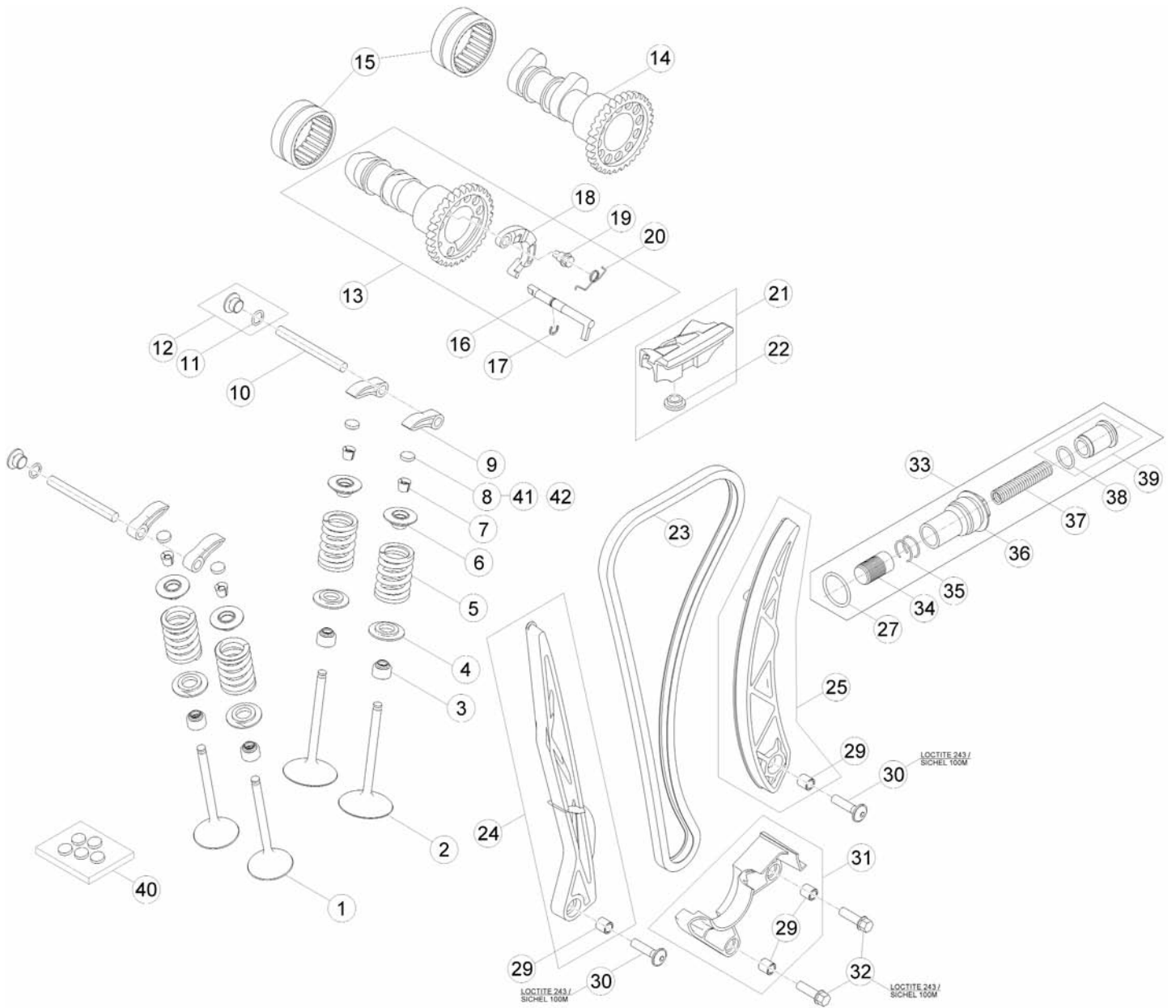

Tav.11A

Pos Loc Pos Ps Pos	Numero Number Numé ro Número Nummer	Q.tà Q.ty Q.té M.ge C.ad	Nota Note Nota Anm.	Descrizione	Description	Dé signation	Beschreibung	Descrìpçì n
22	006.11.066.00.00	1		Boccola	Bush	Moyeu	Büchse	Buje
23	022.11.060.00.00	1		Catena distribuzione Z=124	Timing chain Z=124	Chaî ne de distribution Z=124	Ventilsteuerkette Z=124	Cadena distribuciò n Z=124
24	006.11.061.80.00	1		Pattino fisso	Fixed pad	Patin fixe	Fester Laufschuh	Pati n fijo
25	022.11.062.80.00	1		Pattino mobile	Movable guide	Patin mobile	Gleitstü ck	Zapata mó vil
27	10.66466.000	1		Anello OR 20x2	O-Ring 20x2	Bague d' é tanché ité 20x2	O-Ring 20x2	Anillo OR 20x2
29	006.11.065.00.00	4		Boccola 6,2x9x9	Bush 6,2x9x9	Moyeu 6,2x9x9	Büchse 6,2x9x9	Buje 6,2x9x9
30	31.30792.000	2		Vite TBCE 6x25	Screw TBCE 6x25	Vis TBCE 6x25	Schraube TBCE 6x25	Tornillo TBCE 6x25
31	022.11.064.80.00	1		Protezione catena	Chain protection	Chaî ne protection	Schutzstü ck Kette	Protecciò n catena
32	11.49070.000	2		Bullone 6x20 ch rs	Bolt 6x20 ch rs	Boulon 6x20 ch rs	Bolzen 6x20 ch rs	Tornillo 6x20 ch rs
33	006.11.167.80.00	1		Tendicatena completo	Chain tightener assy.	Tendeur de chaî ne compet	Kettenspanner komplett	Tensor de catena compl.
34	006.11.167.20.00	1		Pistone	Piston	Piston	Kolben	Pistó n
35	28.23105.000	2		Seeger RB14 DIN 7993	Circlip RB14 DIN 7993	Circlip RB14 DIN 7993	Seeger RB14 DIN 7993	Seeger RB14 DIN 7993
36	006.11.167.10.00	1		Bullone tendicatena	Chain tightening bolt	Boulon tendeur de chaî ne	Bolzen Kettenspanner	Perno tensionador de catena
37	006.11.267.30.00	1		Molla tendicatena	Chain tight. spring	Ress.t tend. de ch.	Kettenspanner feder	Muelle tens. de cad.
38	10.66175.000	1		Anello OR 13x1.5	O-Ring 13x1.5	Bague d' é tanché ité 13x1.5	O-Ring 13x1.5	Anillo OR 13x1.5
39	006.11.168.80.00	1		Tappo completo	Complete cap	Bouchon complet	Verschluß komplett	Tapó n completo
40	006.45.001.80.00	1		Kit spessori valvole	Valves insert kit	Jeu elements soupapes	Kit ventileinsatzen	Kit elementos de valvulas

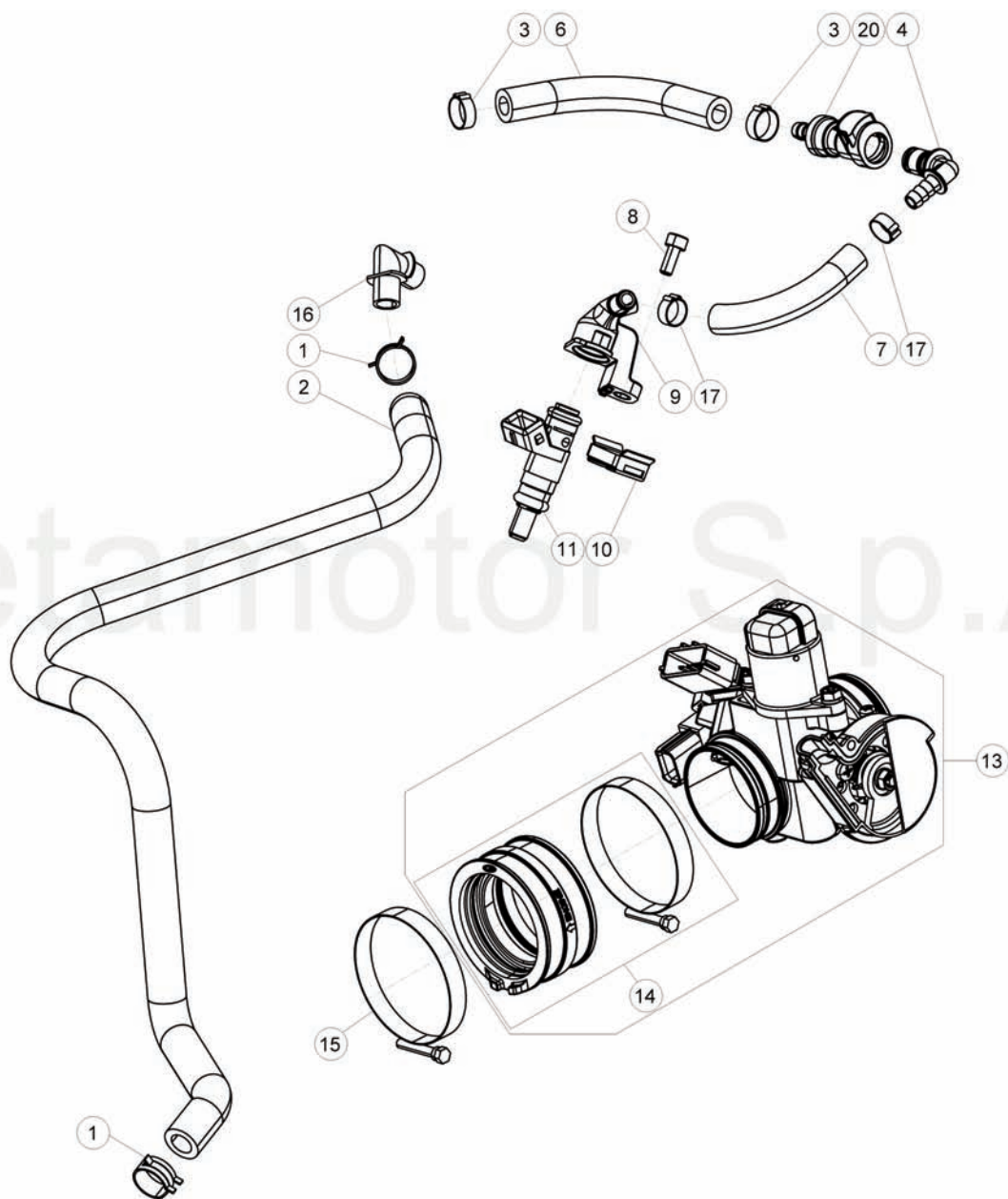

© Copyright 2017 Betamotor S.p.A.



Tav.13

Pos Loc Ps Pos	Numero Number Numéro Número Nummer	Q.tà Q.ty Q.té M.ge C.ad	Nota Note Nota Anm.	Descrizione	Description	Dé signation	Beschreibung	Descrìpziò n
1	10.67470.000	2		Anello stringitubo	Pipe clamping ring	Anneau serre-tube	Schlauchschelle	Anillo prensatubo
2	029.13.002.00.00	1		Tubo ventilazione	Ventilation hose	Tuyau ventilation	Lüftungrohr	Tubo de ventilaciòn
3	C07.16.002.00.00	2		Fascetta autoaggrappante	Self locking clamp	Collier à autoserrage	Selbstklemmende Schelle	Abrazadera con autobloqueo
4	029.13.008.00.00	1		Raccordo rapido tubo benzina	Quick-coupling union gasoline tube	Raccord rapide tuyau d' essence	Steckanschluß Benzinschlauch	Conexiòn ràpida uubo gasolina
6	029.13.025.00.00	1		Tubo benzina	Petrol tube	Tuyau d' essence	Benzinschlauch	Tubo gasolina
7	029.13.026.00.00	1		Tubo benzina	Petrol tube	Tuyau d' essence	Benzinschlauch	Tubo gasolina
8	31.29910.000	1		Vite 5x12	Screw 5x12	Vis 5x12	Schraube 5x12	Tornillo 5x12
9	029.13.028.00.00	1		Cappuccio iniettore	Injector cap	Capuchon injecteur	Kappe Einspritzdüse	Capuchòn inyector
10	029.13.009.15.00	1		Staffa fissaggio	Fastening bracket	Bride fix.	Befestigung	Soporte suj.
11	029.13.005.00.00	1		Iniettore	Injector	Injecteur	Einspritzdüse	Inyector
13	029.13.013.80.00	1		Corpo farfallato	Throttle body	Corps papillon	Drosselklappengehäuse	Cuerpo con mariposa
14	029.13.000.82.00	1		Collettore aspirazione	Inlet manifold	Collecteur Admission	Ansaugstutzen	Colector aspiraciòn
15	15.14607.800	1		Fascetta carburatore d.58 con vite + distanziale	Carburetor clamp d.58 with screw + spacer	Collier carburateur d.58 avec vis + entretoise	Schelle Vergaser d.58 mit Schraube + Distanzstück	Abrazadera carburador d.58 con tornillo + distanciador
16	27.11020.000	1		Raccordo a 90°	Joint p. 90°	Raccord 90°	Stutzen 90°	Racor 90°
17	C07.16.003.00.00	2		Fascetta autoaggrappante	Self locking clamp	Collier à autoserrage	Selbstklemmende Schelle	Abrazadera con autobloqueo
20	031.40.125.00.00	1		Connettore tubo benzina	Quick-coupling union gasoline tube	Raccord rapide tuyau d' essence	Steckanschluß Benzinschlauch	Conexiòn ràpida uubo gasolina

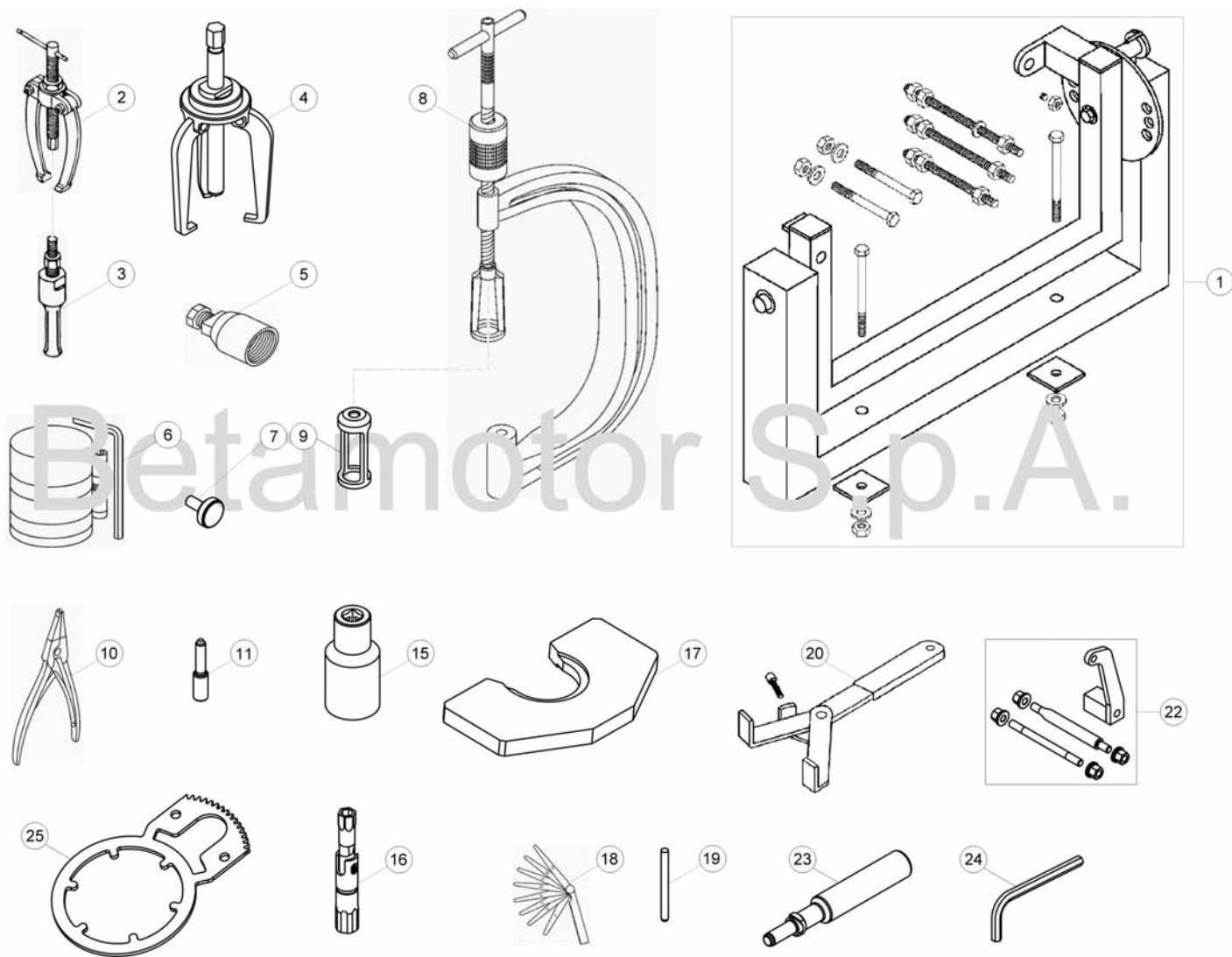

© Copyright 2017 Betamotor S.p.A.

Tav.14

Pos Loc Pos Ps Pos	Numero Number Numéro Número Nummer	Q.tà Q.ty Q.té M.ge C.ad	Nota Note Note Nota Anm.	Descrizione	Description	Dé signation	Beschreibung	Descrìciò n
1	36.25132.000	1		Attrezzatura Mont. Motore	Mounting Rack	Outils Montage Moteur	Montagebock	Aparejos Montaje Motor
2	36.25081.000	1		Estrattore	Extractor	Extracteur	Abziehvorricht	Extractor
3	006.14.016.00.00	1		Estrattore Cuscinetti Interni 20-30MM	Intern. Bearings Puller 20-30MM	Extracteur Roulements Int. 20-30MM	Einsatz 20-30MM	Extractor Cojinetes Int. 20-30MM
4	006.14.015.00.00	1		Estrattore Per Ingranaggi	Extractor For Timing Gear	Extracteur Engranages	Zweiback.Abzieher Steuerritzel	Extractor Engranajes
5	36.25173.000	1		Estrattore volante	Flywheel extractor	Extracteur pour volant	Auszieher für Schwungrad	Extractor volante
6	006.14.017.00.00	1		Serie fasce elastiche	Piston ring set	Jeu de segments piston	Satz kolbenring	Juego de aros de piston
7	006.14.005.00.00	1		Attrezzo sbloccaggio tendicatena	Chain tightener unlocking tool	Deverrouillage tend. de ch.	Entriegelung Kettenspanner	Desenclavamiento tens. de cad.
8	01.00043.000	1		Attrezzo mont.- smont. valvole	Valves ass. and rem. tool	Outil pour mont. dem. soup.	Werkzeug für Ventilmontage	Ut. montaje- desm. válvulas
9	006.14.003.00.00	1		Attrezzo per montaggio molle valvola	Valvespring fitting tool	Outil pour montage des ressorts de soupape	Montagewerkzeug für ventillfedern	Utensilio para el montaje del muelle de la válvula
10	36.25097.000	1		Pinza Speciale Anelli	Special Circlip Plier	Pince Speciale Bagues	Seegerringzange Verkehrt	Pinza Especial Anillos
11	006.14.011.00.00	1		Attrezzo per bloccaggio albero motore al PMS	Tool to hold crankshaft in TDC position	Util d' immobilisation du vilebrequin au PMH	Werkzeug für Kurbelwellenblockierung am OT	Herramienta para bloqueo cigüeñal al PMS
15	006.14.002.00.00	1		Chiave a bussola 36MM	Socket wrench 36MM	Cle a douille 36MM	Schluesseinsatz 36MM	Llave de enchufe 36MM
16	020.44.010.00.00	1		Chiave candela	Ignition wrench	Clé à bougie	Zündkerzenschlüssel	Llave bujía
17	029.14.007.50.00	1		Attrezzo smontaggio biella	Conn.-rod dismantling Tool	Outil de dé montage bielle	Demontagewerkzeug Pleuel	Herramientas desmontaje biela
18	006.14.021.00.00	1		Calibro per gioco valvole	Valve allowance gauge	Calibre jeu soupapes	Lehre Ventilspiel	Calibre para juego de válvulas
19	006.14.018.00.00	1		Calibro differenziale guida valvola	Valve guide gauge	Guide soupape	Lehre Ventilführung	Calibre para guía válvula
20	006.14.004.00.00	1		Chiave di fermo mozzo frizione	Clutch hub retaining wrench	Clé f d' arret moyeu embrayage	Halterungsschlüssel der Kupplungsnahe	Llave bloquear cubo fricción
22	006.14.014.00.00	1		Fissaggi motore	Engine fasteners	Fixations moteur	Motorbefest.	Fijaciones motor
23	022.14.020.00.00	1		Attrezzo anello elastico spinotto	Piston pin circlip tool	Outil pour bague él axe de piston	Werkzeug für Sprengring zur Bolzenfeststellung	Ut. anillo elástico bloquea-clavija
24	006.44.000.00.00	1		Chiave speciale	Special wrench	Clé speciale	Spezialschlüssel	Llave special
25	029.14.002.50.00	1		Chiave speciale	Special wrench	Clé speciale	Spezialschlüssel	Llave special

Tav.31

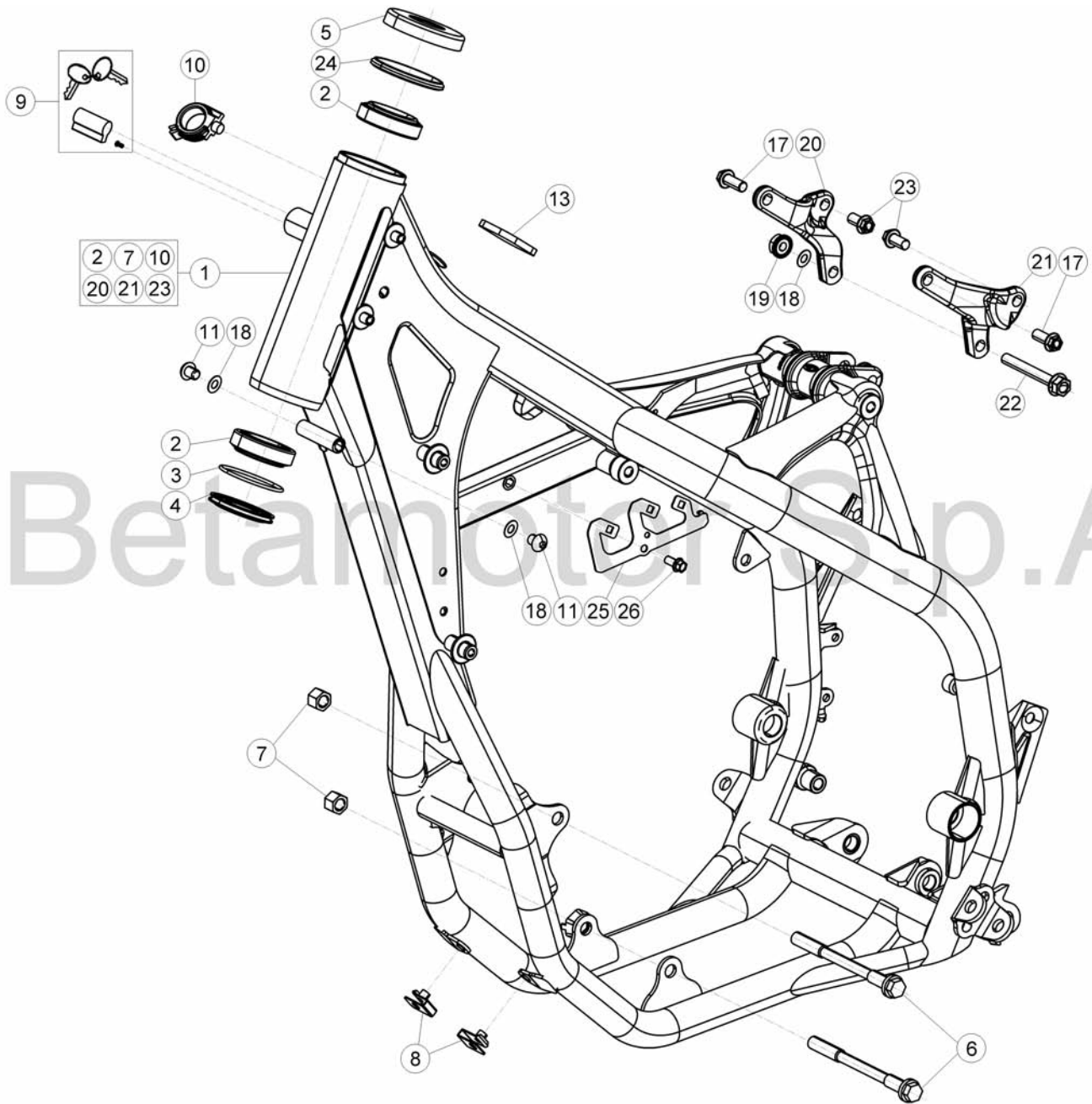

© Copyright 2017 Betamotor S.p.A.



Beta
motorcycles

Tav.31

Pos Loc Ps Pos	Numero Number Numéro Número Nummer	Q.tà Q.ty Q.té M.ge C.ad	Nota Note Nota Anm.	Descrizione	Description	Dé signation	Beschreibung	Descrìpziòn
1	031.31.010.80.50	1		Telaio completo	Frame, assy	Chassis complet	Rahmen, kpl	Bastidor compl.
2	12.99510.000	2		Cuscinetto conico 29x50x15	Conical bearing 29x50x15	Roulement conique 29x50x15	Lager 29x50x15	Cojnete conico 29x50x15
3	10.66935.000	1		Anello OR	O-Ring	Bague d' é tanché ité	O-Ring	Anillo OR
4	020.31.039.00.00	1		Anello parapolvere	Dust cover	Disque pare-poussié re	Staubdeckel	Disco gurdapolvo
5	031.31.016.22.00	1		Protezione cuscinetto	End Cap Bearing	Palier De Bielle	Lagerdeckel	Tapa Rodamiento
6	11.64607.000	2		Perno motore	Engine pin	Axe moteur	Motorbolzen	Perno motor
7	13.21060.000	2		Dado M10X1,25	Nut M10X1,25	Ecrou i M10X1,25	Mutter M10X1,25	Tuerca M10X1,25
8	25.60311.000	2		Piastrina elastica M6	Spring plate M6	Plaqueette é lastique M6	Plättchen M6	Pletina elástica M6
9	28.85861.000	1		Serratura bloccasterzo	Security lock	Serrure blocage guidon	Lenkradschloss	Cerradura bloque manillar
10	25.24441.000	1		Passacavo a scatto	Grommet	Passe-câ ble	Kabeldurchgang	Pasacables
11	31.64018.000	2		Vite M8X10	Screw M8X10	Vis M8X10	Schraube M8X10	Tornillo M8X10
13	031.31.035.00.00	1		Tampone serbatoio	Buffer tank	Silentbloc ré servoir	Puffer tank	Silent-block deposito
17	11.54521.000	2		Vite M8X16	Screw M8X16	Vis M8X16	Schraube M8X16	Tornillo M8X16
18	27.49500.000	3		Rondella	Washer	Rondelle	U.Scheibe	Arandela
19	13.17120.000	1		Dado M8	Nut M8	Ecrou M8	Mutter M8	Tuerca M8
20	020.31.144.00.00	1		Staffa fiss. testa dx.	R.H. cylinder head sec. Bracket	Bride fix. Culasse D.	Kopfbefestigungshalterung R.	Brida fij. culata der.
21	020.31.145.00.00	1		Staffa fiss. testa sx.	L.H. cylinder head sec. Bracket	Bride fix. Culasse G.	Kopfbefestigungshalterung L.	Brida fij. culata izq.
22	11.55970.000	1		Bullone M8x65	Bolt M8x65	Boulon M8x65	Bolzen M8x65	Tornillo M8x65
23	11.54521.000	2		Vite M8X16	Screw M8X16	Vis M8X16	Schraube M8X16	Tornillo M8X16
24	031.32.007.00.00	1		Anello di tenuta	Oil seal	Joint spie	Dichtring	Reté n de aceite
25	031.40.126.22.00	1		Staffa	Bracket	Bride	Halterung	Brida
26	11.47015.000	1		Bullone M6x12 RS CH8	Bolt M6x12 RS CH8	Boulon M6x12 RS CH8	Bolzen M6x12 RS CH8	Tornillo M6x12 RS CH8

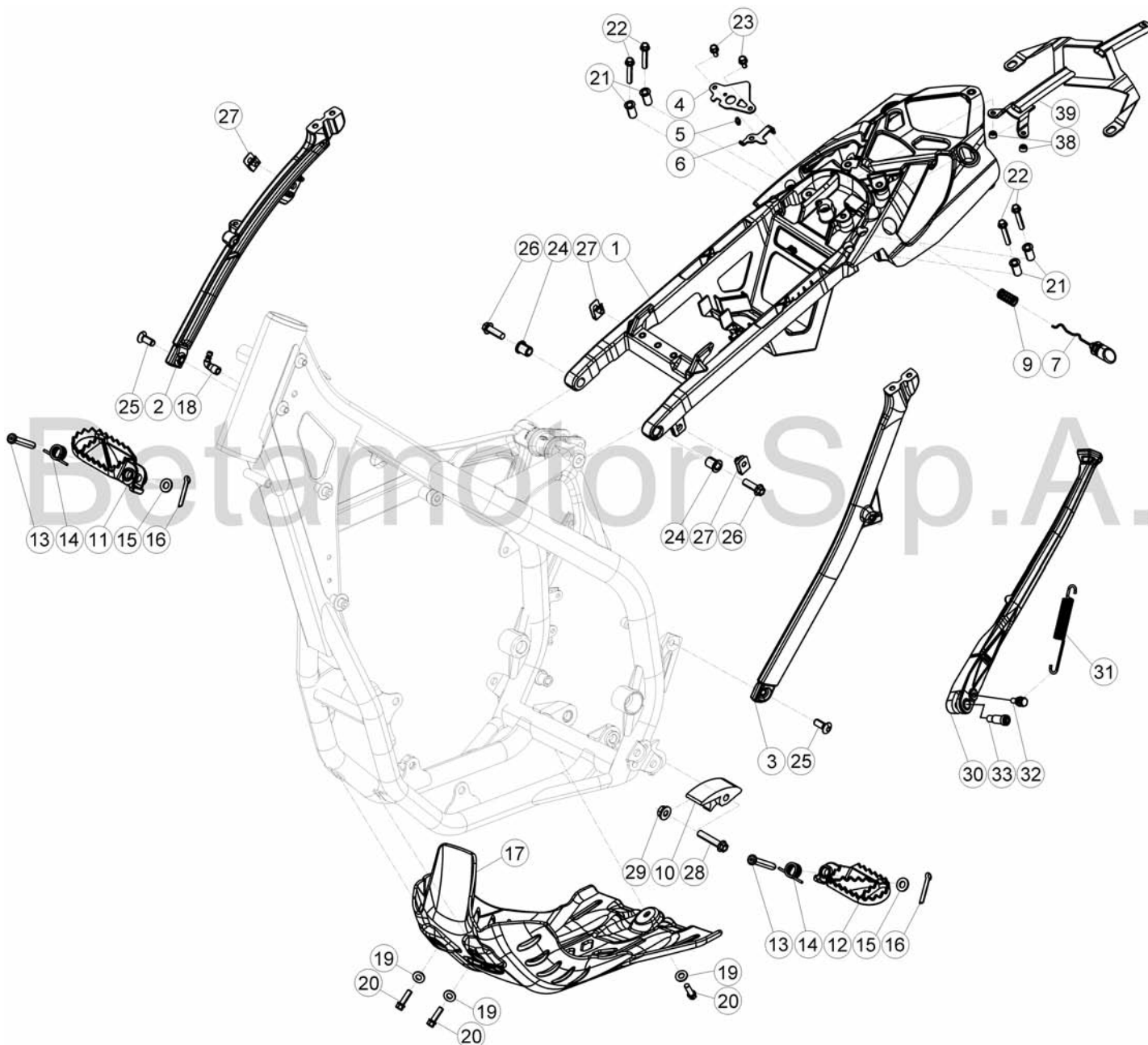

© Copyright 2017 Betamotor S.p.A.



Tav.32

Pos Loc Ps Pos	Numero Number Numéro Nummer	Q.tà Q.ty Q.té M.ge C.ad	Nota Note Nota Anm.	Descrizione	Description	Dé signation	Beschreibung	Descrìciò n
1	031.32.000.37.51	1		Telaioetto superiore	Upper small frame	Châ ssis sup.	Kleiner Rahmen oben	Chasis sup.
2	020.32.100.00.59	1		Braccetto telaioetto Dx	RH link arm	Bras jonction droit	Strebe, rechts	Brazo conexion der.
3	020.32.027.42.59	1		Attacco telaio posteriore sx	Rear LH frame fastening	Fixation châ ssis arriè re gauche	Rahmen befestigung hinten links	Enganche bastidor trasero izq.
4	020.32.010.00.05	1		Piastra fissaggio serratura	Lock sec. Plate	Plaque fix. Serrure	Befestigungsplatte Schloß	Chapa fij. cerradura
5	020.32.112.00.00	1		Perno serratura	Pin	Pivot	Zapfen	Perno
6	020.32.011.00.05	1		Piastra ritegno serratura	Plate	Plaquette	Schild	Placa
7	020.32.013.80.51	1		Bottone serratura	Lock knob	Bouton serrure	Knopf Schloß	Boton cerradura
9	020.32.016.00.00	1		Molla	Spring	Ressort	Feder	Muelle
10	25.25601.000	1		Pattino catena	Chain shoe	Doigt chaine	Gleitauflage	Patí n cadena
11	25.32521.000	1		Pedana dx.	Rubber mat R.H.	Tapis d.	Fußblech rechts	Estribo der.
12	25.32531.000	1		Pedana sx.	Rubber mat L.H.	Tapis g.	Fußblech links	Estribo izq.
13	25.54465.000	2		Perno pedana	Footrest pin	Pivot repose-pied	Rasten Pin	Eje estribera
14	016.32.020.00.00	2		Molla pedanina	Foot rest spring	Ressort repose-pied	Fußblechfeder	Muelle estribo
15	031.32.001.00.00	2		Rondella 10x21x2	Washer 10x21x2	Rondelle 10x21x2	Scheibe 10x21x2	Arandela 10x21x2
16	12.81993.000	2		Copiglia 3x20	Split pin 3x20	Goupille 3x20	Splint 3x20	Grupilla 3x20
17	031.32.005.00.59	1		Protezione motore	Engine protection	Protection moteur	Motorschutz	Protección n motor
18	27.23470.000	1		Raccordo per sfiato	Breather pipe	Raccord pour vidange	Entlüftungsrohranschluß	Racor para ventilació n
19	27.42000.000	3		Rondella 6.18	Washer 6.18	Rondelle 6.18	U.Scheibe 6.18	Arandela 6.18
20	11.49070.000	3		Bullone 6x20 ch rs	Bolt 6x20 ch rs	Boulon 6x20 ch rs	Bolzen 6x20 ch rs	Tornillo 6x20 ch rs
21	020.32.004.00.00	4		Boccola superiore	Upper bush	Douille supé rieure	Obere Buchse	Casquillo superior
22	11.50355.000	4		Bullone M6x35	Bolt M6x35	Boulon M6x35	Bolzen M6x35	Tornillo M6x35
23	31.29810.000	2		Vite M5X12	Screw M5X12	Vis M5X12	Schraube M5X12	Tornillo M5X12
24	020.32.003.00.00	2		Boccola anteriore	Front bush	Douille avant	Vordere Buchse	Casquillo delantero
25	007.32.032.00.00	2		Vite speciale TSBEI M8x20	Special screw TSBEI M8x20	Vis spé ciale TSBEI M8x20	Spezialschraube TSBEI M8x20	Tornillo especial TSBEI M8x20
26	31.64070.000	2		Vite flangiata 8x30	Flanged screw 8x30	Vis à brides 8x30	Flanschschraube 8x30	Tornillo rebordeado 8x30
27	25.60311.000	3		Piastrina elastica M6	Spring plate M6	Plaquette é lastique M6	Plättchen M6	Pletina elástica M6
28	11.55480.000	1		Vite M8x40	Screw M8x40	Vis M8x40	Schraube M8x40	Tornillo M8x40
29	13.17020.000	1		Dado autoblocc. Basso M8	Nut M8	Ecrou M8	Mutter M8	Tuerca M8
30	031.32.070.00.00	1		Cavalletto	Central stand	Bé quille	Kippständer	Caballette
31	020.32.026.00.00	1		Molla cavalletto	Central stand spring	Ressort bé quille	Feder Kippständer	Muelle caballete
32	11.66615.000	1		Bullone spec. piastra cavalletto	Central stand special bolt	Boulon spec. plaque bé q.	Spezialschraube Kippständerplatte	Tornillo especial chapa caballete
33	11.66614.000	1		Bullone spec. cavalletto	Special bolt	Boulon spec.	Spezialschraube	Tornillo especial
38	13.12610.000	2		Dado autoagganciante PS.M6.3	Self-clinching nut PS.M6.3	Ecrou à sertir PS.M6.3	Einpressmutter PS.M6.3	Tuerca remachable PS.M6.3
39	031.32.078.40.59	1		Telaioetto di irrigidimento posteriore	Rear frame	Châ ssis arriè re	Kleiner Rahmen hinten	Chasis trasero

Tav.33A

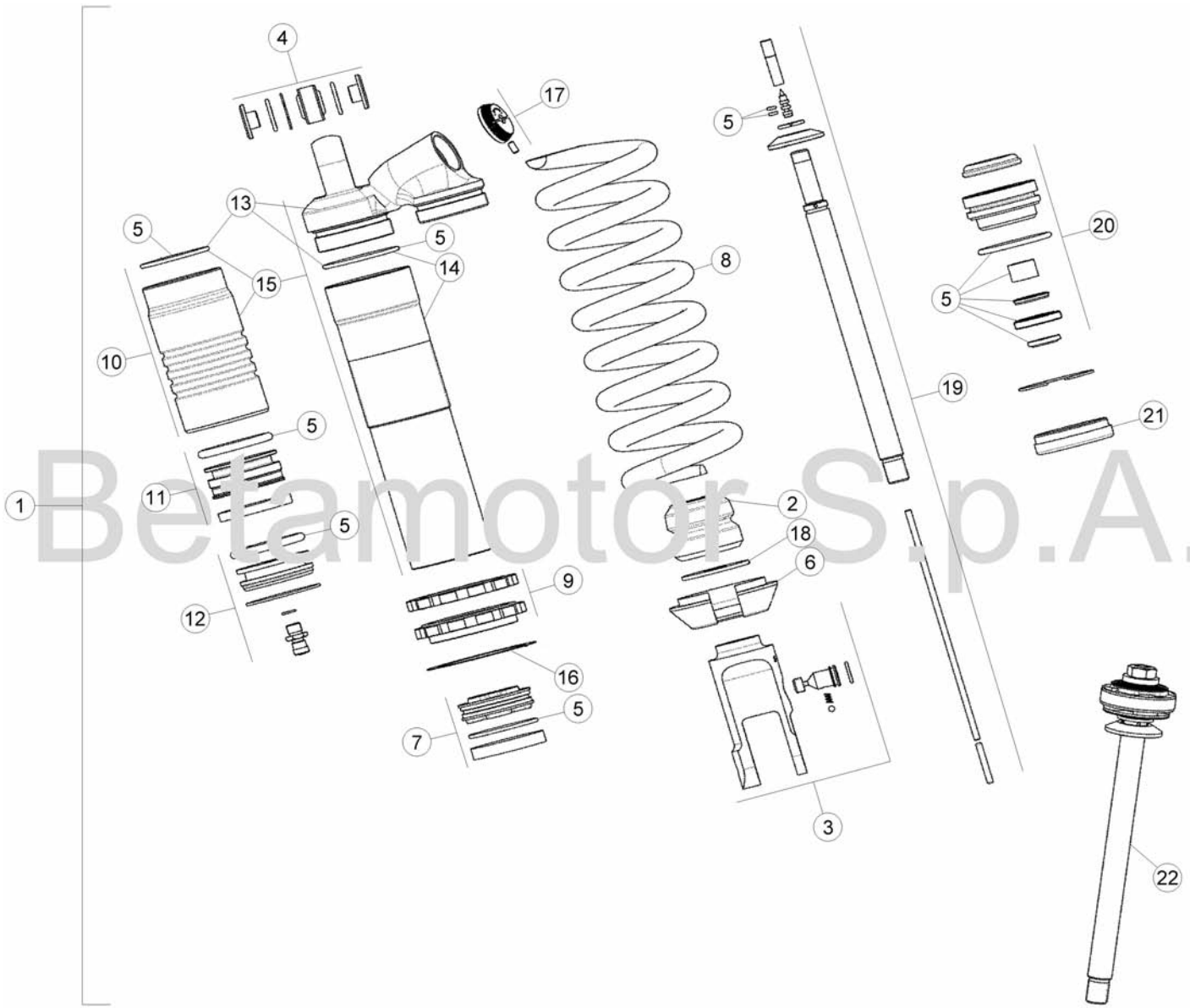

© Copyright 2017 Betamotor S.p.A.



Tav.33A

Pos Loc Ps Pos	Numero Number Numéro Número Nummer	Q.tà Q.ty Q.té M.ge C.ad	Nota Note Nota Anm.	Descrizione	Description	Dé signation	Beschreibung	Descrìpziòn
1	031.33.023.80.00	1		Ammortizzatore completo	Shock absorber assembly	Amortisseur complet	Stoßdämpfer komplett	Amortiguador completo
2	020.33.141.00.00	1		Tampone	Buffer	Silentbloc	Puffer	Silent-block
3	031.33.006.00.00	1		Gruppo forchetta ammortizz.	Shock absorber inf. Connection	Fixation inférieure amortisseur	Untere Befestigung Stossdämpfer	Fijador inferior amortiguador
4	13.86078.800	1		Kit distanziali ammortizzatore	Damper spacer kit	Jeu entretoises amortisseur	Kit Stoßdämpfer Distanz	Juego distanciador amortiguador
5	031.33.044.00.00	1		Gruppo guarnizioni	Gasket set	Groupe garnitures	Dichtungssatz	Grupo juntas
6	15.39110.000	1		Fondello	Cup	Godet	Deckel	Cazoleta
7	031.33.141.00.00	1		Pistone completo	Piston set	Piston compl.	Kolben, kompl.	Pistón, compl.
8	020.33.143.00.00	1		Molla 5,4k	Spring 5,4k	Ressort 5,4k	Feder 5,4k	Muelle 5,4k
9	031.33.005.00.00	1		Gruppo ghiera	Ring nuts	Douilles	Gewinderingen	Casquillos
10	031.33.007.00.00	1		Serbatoio ammortizzatore	Shock absorber tank	Réservoir de l'amortisseur	Gasbehälter für Stoßdämpfer	Depósito amortiguador
11	031.33.008.00.00	1		Gruppo diaframma	Diaphragm assy	Groupe diaphragme	Biegeplattegruppe	Grupo diafragma
12	031.33.009.00.00	1		Gruppo tappo	Plug assy	Groupe bouchon	Verschlussgruppe Kpl	Grupo tapón
13	031.33.010.00.00	1		Basetta	Bracket	Support	Halter	Soporte
14	031.33.011.00.00	1		Corpo ammortizzatore	Damper body	Corps de l'amortisseur	Dämpfungskörper	Cuerpo amortiguador
15	031.33.011.80.00	1		Ammortizzatore completo	Shock absorber assembly	Amortisseur complet	Stoßdämpfer komplett	Amortiguador completo
16	031.33.012.00.00	1		Rosetta	Washer	Rondelle	Federring	Arandela
17	031.33.013.00.00	1		Volantino	Handwheel	Roue a main	Handrad	Rueda de mano
18	031.33.014.00.00	1		Rondella	Washer	Rondelle	U.Scheibe	Arandela
19	031.33.015.00.00	1		Stelo	Stem	Tige	Stange	Varilla
20	031.33.016.00.00	1		Gruppo guida stelo	Guide rod assy	Groupe guide tige	Pumpenstößelgruppe	Grupo guja espiga
21	031.33.017.00.00	1		Gruppo tappo ammortizzatore	Shock-absorber plug assy.	Groupe bouchon amortisseur	Verschlussgruppe Kpl	Grupo tapón amortiguador
22	031.33.143.80.00	1		Stelo completo	Operating rod, assy.	Tige compl.	Kolbenstange, kompl.	Varilla completa

Tav.33B

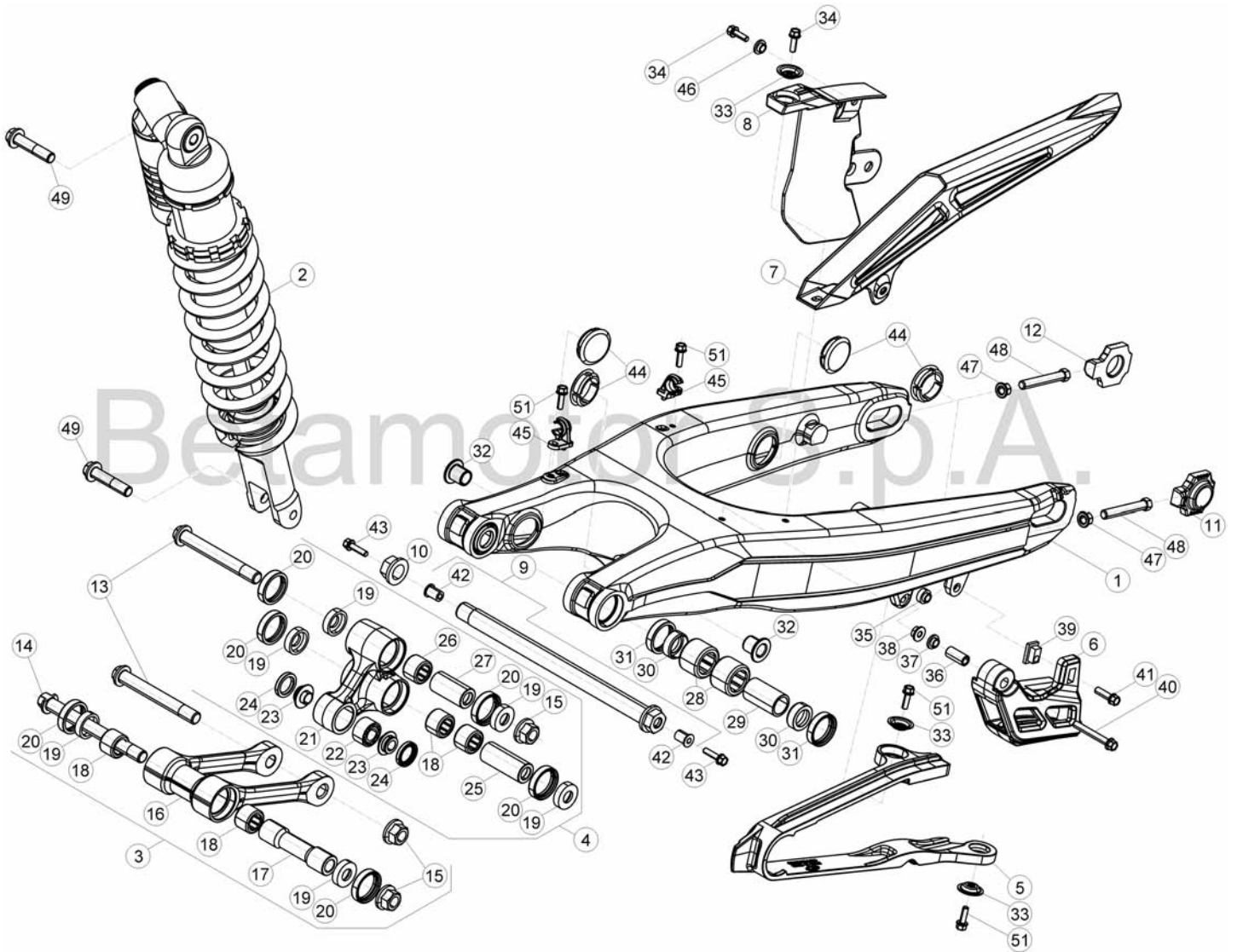

© Copyright 2017 Betamotor S.p.A.

Tav.33B

Pos Loc Ps Pos	Numero Number Numéro Nummer	Q.tà Q.ty Q.té M.ge C.ad	Nota Note Note Anm.	Descrizione	Description	Dé signation	Beschreibung	Descrìpziò n
1	031.33.019.00.59	1		Forcellone	Big fork	Fourche	Radschwinge	Horquilla
2	031.33.023.80.00	1		Ammortizzatore	Damper	Amortisseur	Stoßdämpfer	Amortiguador
3	020.33.030.80.00	1		Biellezza	Connecting rod	Biellette	Bolzensange	Bieleza
4	020.33.020.80.00	1		Bilanciere	Lever	Balancier	Kipphebel	Balancin
5	020.33.015.00.00	1		Tassello guidacatena super.	Upper sliding block	Cheville guide de chaine sup.	Schwingschleifklotz oben	Protector cadena superior
6	29.10071.000	1		Tassello guidacatena infer.	Lower sliding block	Cheville guide de chaine inf.	Schwingschleifklotz unten	Protector cadena inferior
7	12.88591.159	1		Copricatena superiore	Up. Chain cover	Couvre-chaîne superieur	Kettenschutz oben	Cubrecadena superior
8	12.88594.159	1		Copricatena inferiore	Lower chain cover	Couvre-chaîne inferieur	Kettenschutz unten	Cubrecadena inferior
9	031.33.142.80.00	1		Perno forcellone	Swingarm pivot	Axe fourche AR.	Schwingbolzen	Eje basculante
10	13.27121.000	1		Dado speciale	Special nut	Ecrou spéciale	Spezialmutter	Tuerca especial
11	29.11866.100	1		Tendicatena SX	Chain adjuster L.	Tendeur de chaine G.	Kettenspanne L.	Tensor de cadena l.
12	29.11865.100	1		Tendicatena DX	Chain adjuster R.	Tendeur de chaine D.	Kettenspanner R.	Tensor de cadena D.
13	11.63992.000	2		Vite speciale M12	Special screw M12	Vis spéciale M12	Spezialschraube M12	Tornillo especial M12
14	020.33.032.00.00	1		Vite speciale M12	Special screw M12	Vis spéciale M12	Spezialschraube M12	Tornillo especial M12
15	13.21130.000	3		Dado autobloccante M12	Self locking nut M12	Ecrou de sécurité M12	Mutter, selbstsichernd M12	Tuerca de seguridad M12
16	020.33.030.00.00	1		Biellezza	Connecting rod	Biellette	Bolzensange	Bieleza
17	020.33.031.00.00	1		Distanziale	Spacer	Entretoise	Distanzstück	Distanciadador
18	11.22055.000	4		Boccola a rulli 20x26x16	Roller bearing 20x26x16	Douille à roulements 20x26x16	Rollenbuchse 20x26x16	Caja de grasa de rodillos 20x26x16
19	28.14083.000	6		Scodellino	Stop washer	Rondelle d'ar	Federaufnahme	Platillo
20	10.64481.000	6		Paraolio	Oil seal	Pare-huile	Dichtring	Sello de lub.
21	020.33.020.00.00	1		Bilanciere	Lever	Balancier	Kipphebel	Balancin
22	16.17310.000	1		Boccola a rulli 12x24x30	Roller bearing 12x24x30	Douille à roulements 12x24x30	Rollenbuchse 12x24x30	Caja de grasa de rodillos 12x24x30
23	11.21920.000	2		Boccola	Bush	Moyeu	Büchse	Buje
24	10.56020.000	2		Paraolio 16x24x4	Oil seal 16x24x4	Pare-huile 16x24x4	Dichtring 16x24x4	Sello de lub. 16x24x4
25	13.62813.000	1		Distanziale 12x20x50	Spacer 12x20x50	Entretoise 12x20x50	Distanzstück 12x20x50	Distanciadador 12x20x50
26	11.22061.000	1		Boccola a rulli 20x26x30	Roller bearing 20x26x30	Douille à roulements 20x26x30	Rollenbuchse 20x26x30	Caja de grasa de rodillos 20x26x30
27	13.62812.000	1		Distanziale 12x20x40	Spacer 12x20x40	Entretoise 12x20x40	Distanzstück 12x20x40	Distanciadador 12x20x40
28	11.22056.000	4		Boccola a rullini 22x28x12	Roller cage 22x28x12	Cage Aiguille 22x28x12	Rollenkäfig 22x28x12	Jaula rodillos 22x28x12
29	13.49183.000	2		Distanziale forcellone	Big fork spacer	Entretoise fourche	Distanzstück Radschwinge	Distanciadador horquilla
30	28.14081.000	4		Scodellino	Stop washer	Rondelle d'ar	Federaufnahme	Platillo
31	10.64481.000	4		Paraolio	Oil seal	Pare-huile	Dichtring	Sello de lub.
32	020.33.001.00.00	2		Boccola	Bush	Moyeu	Büchse	Buje
33	27.74786.000	3		Rondella bombata	Kasher	Rondelle	Scheibe	Arandela
34	11.46360.000	2		Bullone flangiato M5x16	Head Flanged bolt M5x16	Boulon Bridé M5x16	Bundbolzen M5x16	Bulón con Brida M5x16
35	13.12610.000	1		Dado	Nut	Ecrou	Mutter	Tuerca
36	13.49191.000	1		Distanziale	Spacer	Entretoise	Distanzstück	Distanciadador
37	13.54820.000	1		Distanziale 6,5x9,0x13,5	Spacer 6,5x9,0x13,5	Entretoise 6,5x9,0x13,5	Distanzstück 6,5x9,0x13,5	Distanciadador 6,5x9,0x13,5
38	13.13020.000	1		Dado autobloccante M6	Self locking nut M6	Ecrou de sécurité M6	Mutter, selbstsichernd M6	Tuerca de seguridad M6
39	13.48868.000	1		Distanziale tassello guidacatena	Sliding block spacer	Entretoise cheville guide de chaine	Abstandstück Schwingschleifklotz	Separador protector cadena/basculante
40	11.05535.000	1		Bullone 6.50 rs ch 8	Bolt 6.50 rs ch 8	Boulon 6.50 rs ch 8	Bolzen 6.50 rs ch 8	Tornillo 6.50 rs ch 8
41	11.49070.000	1		Bullone 6x20 ch rs	Bolt 6x20 ch rs	Boulon 6x20 ch rs	Bolzen 6x20 ch rs	Tornillo 6x20 ch rs
42	27.33740.000	2		Rivetto filettato M6	Threaded rivet M6	Rivet fileté M6	Niete mit gewinde M6	Remache roscado
43	11.46401.000	2		Bullone M5x20	Bolt M5x20	Boulon M5x20	Bolzen M5x20	Tornillo M5x20
44	29.10596.136	4		Tappo forcellone D30	Big fork plug D30	Bouchon fourche D30	Radschwinge verschluß D30	Tapón horquilla D30
45	15.14605.000	2		Passatubo	Grommet	Passe-tube	Rohrdurchgang	Pasa-tubo
46	13.54820.000	1		Distanziale 6,5x9,0x13,5	Spacer 6,5x9,0x13,5	Entretoise 6,5x9,0x13,5	Distanzstück 6,5x9,0x13,5	Distanciadador 6,5x9,0x13,5
47	13.17122.000	2		Dado speciale M8 CH 13	Special nut M8 CH 13	Ecrou spéciale M8 CH 13	Spezialmutter M8 CH 13	Tuerca especial M8 CH 13
48	11.55909.000	2		Bullone M8x55	Bolt M8x55	Boulon M8x55	Bolzen M8x55	Tornillo M8x55
49	11.62050.000	2		Bullone fiss. ammortizzatore M10x45	Damper sec. bolt M10x45	Boulon fix. amortisseur M10x45	Befestigungsbolzen M10x45	Tornillo fij amortiguador M10x45
51	11.46251.000	4		Bullone flangiato M5x12	Head Flanged bolt M5x12	Boulon Bridé M5x12	Bundbolzen M5x12	Bulón con Brida M5x12

Tav.34

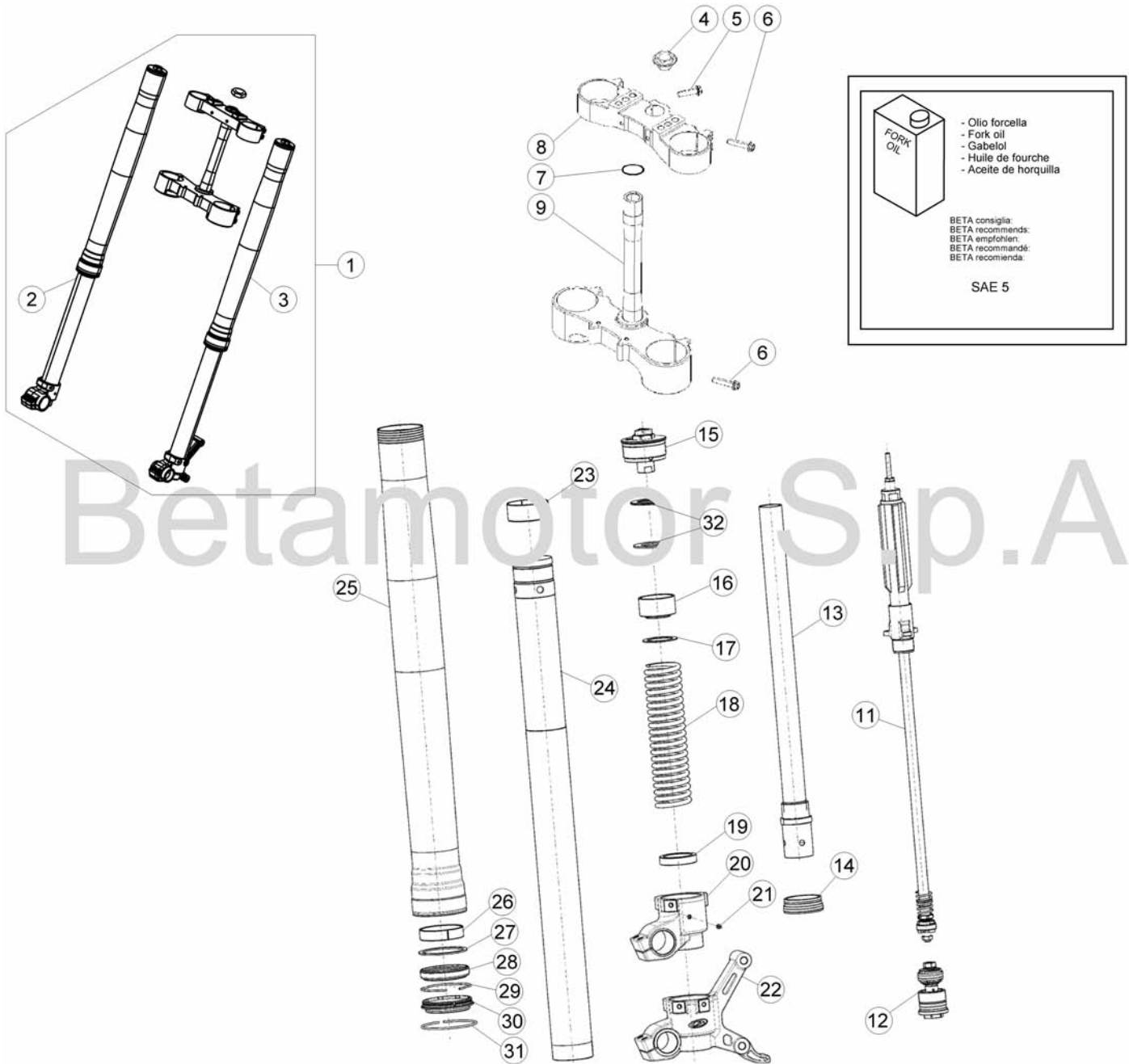

© Copyright 2016 Betamotor S.p.A.



Beta
motorcycles

Tav.34

Pos Loc Pos Ps Pos	Numero Number Numéro Número Nummer	Q.tà Q.ty Q.té M.ge C.ad	Nota Note Note Nota Anm.	Descrizione	Description	Désignation	Beschreibung	Descripció
1	031.34.055.80.00	1		Forcella completa	Stirrup assy.	Fourchette compl.	Schaltgabel, Kompl.	Horquilla compl.
2	031.34.057.80.59	1		Gamba DX	RH leg	Tube D.	Rechte Beineinheit	Pata derecha
3	031.34.056.80.59	1		Gamba SX	LH leg	Tube G.	Linke Beineinheit	Pata izquierda
4	020.34.004.00.00	1		Dado 20X1,5	Nut 20X1,5	Ecrou 20X1,5	Mutter 20X1,5	Tuerca 20X1,5
5	11.55440.000	1		Bullone 8x30 ch10 rs	Bolt 8x30 ch10 rs	Boulon 8x30 ch10 rs	Bolzen 8x30 ch10 rs	Tornillo 8x30 ch10 rs
6	11.55510.000	8		Bullone M8x40	Bolt M8x40	Boulon M8x40	Bolzen M8x40	Tornillo M8x40
7	10.66420.000	1		Anello OR 20,22,3,53 NBR	O-Ring 20,22,3,53 NBR	Bague d' é tanché ité 20,22,3,53 NBR	O-Ring 20,22,3,53 NBR	Anillo OR 20,22,3,53 NBR
8	031.34.051.42.04	1		Piastra di sterzo superiore	Steering head	Tête de direction	Gabelkopf	Tija superior
9	031.34.041.80.04	1		Piastra di sterzo inferiore	Steering crown with pin	Socle de direction avec pivot	Untere Gabelbrücke mit Bolzen	Base de direcció n con perno
11	026.34.366.00.00	2		Gruppo estensione	Rebound unit	Ecrou groupe dé tente	Zugstufengruppe	Grupo rebote
12	026.34.365.00.00	2		Gruppo compressione	Compression unit	Groupe compression	Druckstufengruppe	Grupo compresió n
13	026.34.017.00.00	2		Tubo interno	Inner tube	Tube inté rieur	Gabel Innenrohr	Tubo interior
14	020.34.313.00.00	2		Anello appoggio stelo + O-Ring	Stem supporting ring + O-Ring	Anneau appui tige + O-Ring	Anlagering für stange + O-Ring	Anillo de apoyo varilla + O-Ring
15	031.34.022.00.00	2		Gruppo tappo	Plug assy	Groupe bouchon	Verschlussgruppe Kpl	Grupo tapó n
16	026.34.358.00.00	2		Distanziale in nylon	Nylon spacer	Entretoise en nylon	Nylon-Distanzstück	Separador de nylon
17	031.34.323.00.00	2		Rosetta	Washer	Rondelle	Federring	Arandela
18	031.34.025.00.00	2		Molla	Spring	Ressort	Feder	Muelle
19	031.34.026.00.00	2		Anello centraggio	Centering ring	Bague de centrage	Zentrierring	Anillo de centrage
20	020.34.331.00.00	1		Piedino dx forcella	R.H. fork foot	Pied de fourche droit	Gabelfuß rechts	Pata horquilla der.
21	020.34.308.00.00	2		Grano	Dowel	Goujon	Stift	Clavija
22	020.34.311.00.00	1		Piedino sx forcella	L.H. fork foot	Pied de fourche gauche	Gabelfuß links	Pata horquilla izq.
23	020.34.320.00.00	2		Boccola Ø49/47 L 20	Bush Ø49/47 L 20	Moyeu Ø49/47 L 20	Bü chse Ø49/47 L 20	Buje Ø49/47 L 20
24	031.34.021.00.00	2		Stelo	Stem	Tige	Stange	Varilla
25	026.34.363.00.00	2		Fodero	Sleeve	Protection	Schutzstück	Protecció n
26	031.34.020.00.00	2		Boccola ø52/48 L15	Bush ø52/48 L15	Moyeu ø52/48 L15	Bü chse ø52/48 L15	Buje ø52/48 L15
27	020.34.318.00.00	2		Distanziale	Spacer	Entretoise	Distanzstück	Distanciadó r
28	020.34.317.00.00	2		Guarnizione	Packing	Joint	Dichtung	Junta
29	020.34.316.00.00	2		Seeger Ø58,45	Circlip Ø58,45	Circlip Ø58,45	Seeger Ø58,45	Seeger Ø58,45
30	020.34.315.00.00	2		Raschiapolvere	Dust scraper	Graffe poussiere	Staubabstreifer	Esc. polvo
31	026.34.364.00.00	2		Anello d' arresto	Check ring	Bague d' arrê t	Sicherungsring	Anillo de bloqueo
32	031.34.023.00.00	2		Svincolo molla	Anti-friction spring	Anti-friction pour ressort	Anti-Reibungsfeder	Antifricció n muelle

Tav.35

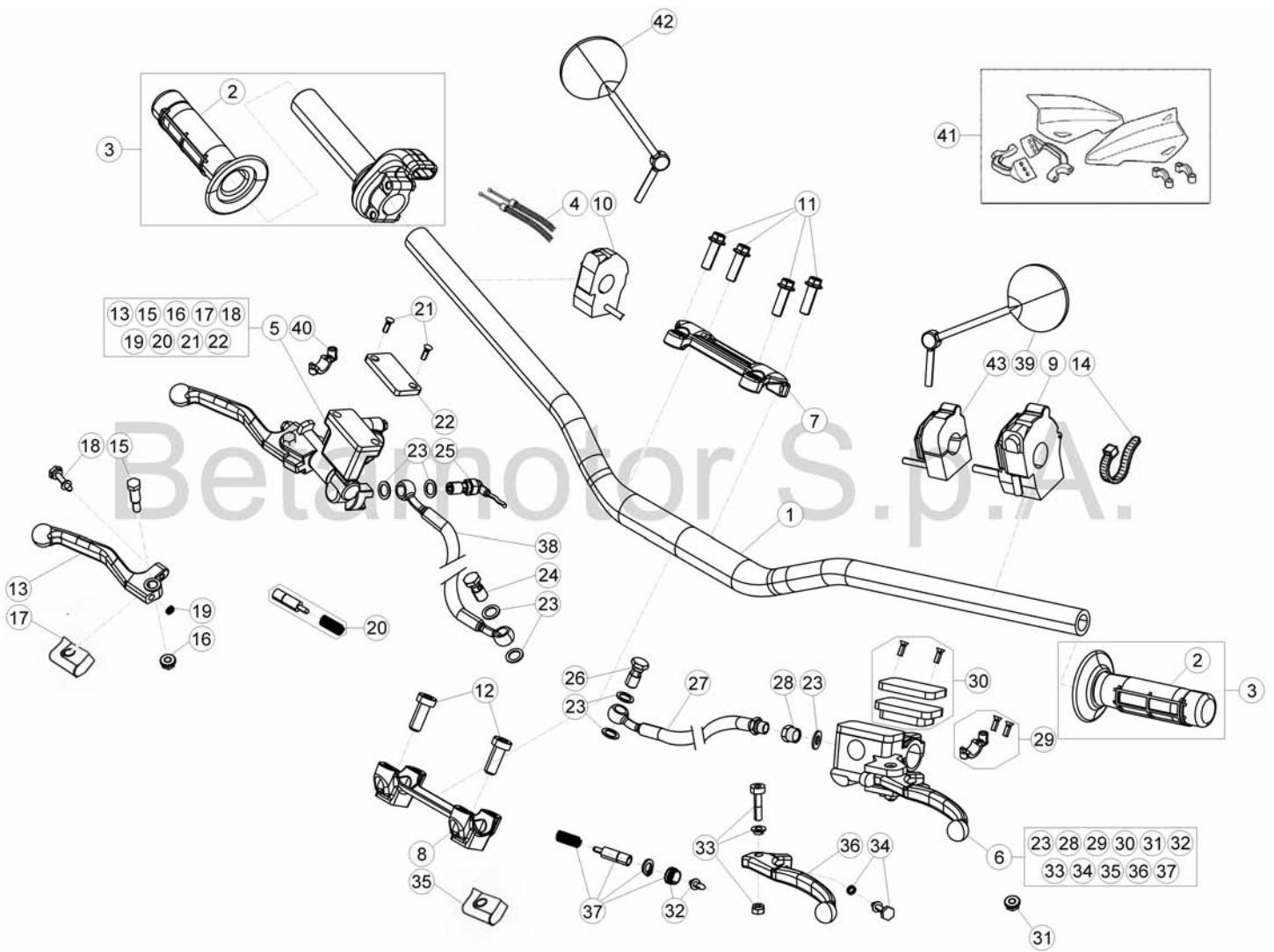

© Copyright 2017 Betamotor S.p.A.



Beta
motorcycles

Tav.35

Pos Loc Pos Ps Pos	Numero Number Numé ro Número Nummer	Q.tà Q.ty Q.té M.ge C.ad	Nota Note Note Nota Anm.	Descrizione	Description	Dé signation	Beschreibung	Descrìpziò n
1	026.35.000.00.59	1		Manubrio	Handlebars	Guidon	Lenker	Manillar
2	036.35.005.00.00	1		Coppia manopole	Grips (couple)	Poigné es (couple)	Handgriffpaar	Manecilla (juego)
3	031.35.009.80.00	1		Comando gas con manopole	Throttle controlwith grips	Comm. gaz avec poigné es	Gasdrehgriff mit handgriffpaar	Mando gas con manecillas
4	031.35.007.82.00	1		Trasmissione gas	Throttle transmiss.	Transmission gaz	Gaszug	Transmisión gas
5	21.02057.059	1		Leva freno ant.	Fr. br. lever	Lev. fr. AV.	Vorderradbremshebel	Pal. fr. del.
6	020.35.120.82.00	1		Leva comando frizione	Clutch control lever	Levier de commande embrayage	Kupplungshebel	Palanca mando embrague
7	12.08253.000	1		Cavallotto superiore	Upper u bolt	Etrier sup.	Obere Brü cke	Brida sup.
8	12.08263.000	1		Cavallotto inferiore	Lower u bolt	Etrier inférieure	Untere Brü cke	Brida inferior
9	016.35.010.00.00	1		Commutatore luci	Lights switch	Commutateur feux	Lichtschalter	Conmutador luces
10	026.40.047.00.00	1		Dispositivo ON-OFF	ON-OFF device	Dispositif ON-OFF	Lichtschalter ON-OFF	Dispositivo ON-OFF
11	31.64070.000	4		Vite flangiata 8x30	Flanged screw 8x30	Vis à brides 8x30	Flanschschraube 8x30	Tornillo rebordado 8x30
12	31.65626.000	2		Vite a brugola M10 25	Allen screw M10 25	Vis à 6 pans M10 25	Sechskantschraube M10 25	Tornillo a llave allen M10 25
13	21.27104.000	1		Leva freno	Brake lever	Levier du frein	Bremshebel	Palanca de freno
14	15.14264.000	1		Fascetta	Clamp	Collier	Schelle	Abrazadera
15	31.96832.000	1		Vite leva freno	Brake lever screw	Vis levier frein	Bremshebelschraube	Vite leva freno
16	13.30911.000	1		Dado	Nut	Ecrou	Mutter	Tuerca
17	16.33841.000	1		Coprileva	Lever cover	Couvre levier	Hebeldeckel	Cubre-palanca
18	31.88604.000	1		Vite regol. leva	Adjusting screw	Vis régl age	Einstellschrauben	Tornillo reg.
19	22.38704.000	1		Molla registro leva freno ant.	Front brake lever adjust spring	Ressort enregistrement levier	Regelfeder vorderradbremse	Muelle regul. bomba freno
20	20.08258.000	1		Pistoncino completo pompa	Piston assy, pump	Piston compl. pompe	Kolben kplt. Pumpe	Piston completo bomba
21	31.23410.052	2		Vite fiss. coperchio	Cover sec. screw	Vis de fix. couvercle	Schraube	Tornillo
22	031.36.003.82.00	1		Coperchio pompa freno	Brake pump cover	Couvercle pompe frein	Deckel Bremspumpe	Tapa bomba freno
23	16.50510.000	8		Guarnizione 10x15x1 in rame	Gasket 10x15x1 copper	Joint 10x15x1 cuivre	Dichtung 10x15x1 Kupfer	Junta 10.15.1 (cobre)
24	031.36.004.00.00	1		Tubo Freno Ant.	Front brake tube	Tuyau du frein AV.	Vordere Bremsleitung	Tubo freno delantero
25	18.89621.000	1		Interruttore stop	Stop switch	Interrupteur stop	Stopschalter	Interruptor stop
26	11.65040.000	1		Bullone forato 10x1 x tubo freno	Special bolt	Boulon 10x1 x tube frein	Hohlschraube F.Bremse	Tornillo esp. talad.10.1
27	020.35.021.00.00	1		Tubo frizione	Clutch tube	Canalisation embrague	Kupplungsrohr	Tubo embrague
28	020.35.032.00.00	1		Raccordo	Joint	Raccord	Stutzen	Racor
29	020.35.122.00.00	1		Cavallotto leva frizione con attacco specchio	Clutch lever u-bolt with mirror fastening	Etrier levier embrayage avec fixation retroviseur	Brü cke Kupplungshebel mit Befestigung für Rückspiegel	Brida palanca embrague con anclaje espejo
30	020.35.023.00.00	1		Coperchio pompa frizione	Clutch pump cover	Couvercle pompe embrayage	Deckel Kupplungspumpe	Tapa bomba embrague
31	020.35.028.00.00	1		Antiemulsione	Antiemulsion	Antiemulsion	Eulsionswidriger	Antiemulsion
32	020.35.029.00.00	1		Puntalino leva pompa	Push piece	Piece de pression	Druckstück	Varilla de presión
33	020.35.024.00.00	1		Perno leva	Lever pin	Goujon levier	Hebelstift	Perno palanca
34	020.35.030.00.00	1		Guidamolla	Spring guide	Guide ressort	Federführung	Guia resorte
35	020.35.027.00.00	1		Gomma protezione leva	Lever protection grommet	Caoutchouc protection levier	Gummi Hebelchutz	Goma protección palanca
36	020.35.022.00.00	1		Leva frizione nuda	Clutch lever, only	Levier d' embrayage nue	Kupplungshebel	Palanca embrague
37	020.35.026.00.00	1		Kit pistoncino pompa	Piston kit master cyl.	Kit piston. maî tre cyl.	Kolbensatz hauptbremszylinder	Kit pistón bomba
38	11.65053.000	1		Bullone forato 10x1,25	Special bolt 10x1,25	Boulon 10x1,25 tube frein	Hohlschraube F.Bremse 10x1,25	Tornillo esp. talad. 10x1,25
39	28.92925.000	1		Specchio retrovisore sx.	LH rear view mirror	Retroviseru gauche	Rückspiegel links	Espejo retrovisor izquierdo
40	12.30100.000	1		Cavallotto leva freno con attacco specchio	Brake lever u-bolt with mirror fastening	Etrier levier frein avec fixation retroviseur	Brü cke Bremshebel mit Befestigung für Rückspiegel	Brida palanca freno con anclaje espejo
41	026.46.005.82.97	1		Kit paramani	Hand guards kit	Kit pare-mains	Kit Handschutz	Kit para manos
42	28.92927.000	1		Specchio retrovisore dx.	R.H. rear mirror	Ré troviseur dr.	Rückspiegel R.	Retrovisor der.
43	031.40.003.00.00	1		Dispositivo switch mappa CDI	Switch for double map CDI	Selecteur mappe CDI	Mappingschalter CDI	Conmutador para cambiar el mapa del CDI



- Olio freni
- Brake fluid
- Bremsflüssigkeit
- Liquide de frein
- El líquido de frenos

BETA consiglia:
BETA recommends:
BETA empfohlen:
BETA recommandé:
BETA recomienda:

BRAKE FLUID DOT 4
BRAKE FLUID DOT 5.1

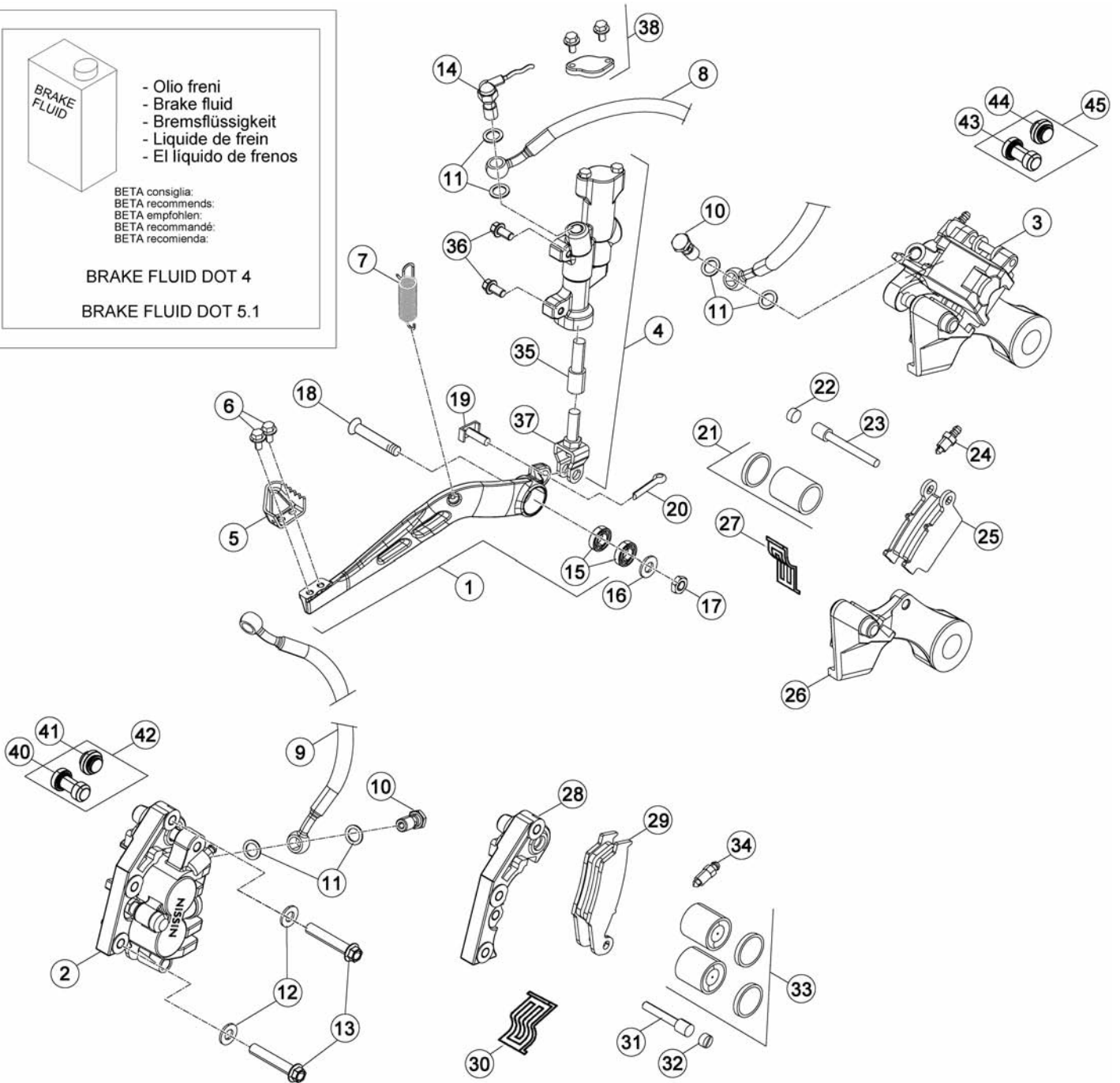

Tav.36

Pos Loc Pos Ps Pos	Numero Number Numé ro Número Nummer	Q.tà Q.ty Q.té M.ge C.ad	Nota Note Note Nota Anm.	Descrizione	Description	Dé signation	Beschreibung	Descrìpçì n
1	020.36.001.80.00	1		Pedale freno	Brake pedal	Pé dale frein	Fussbremspedal	Pedal freno
2	25.03056.000	1		Pinza freno anteriore	Front disk brake caliper	Etrier de frein AV.	Bremszange-Scheibe	Pinza freno del.
3	25.03066.000	1		Pinza freno posteriore	Rear disk brake caliper	Etrier de frein AR.	Bremszange	Pinza del freno tras.
4	25.91178.000	1		Pompa freno posteriore	Rear brake cylinder	Maî tre cylindre frein ar.	Hauptbremszylinder Hinterradbremse	Bomba freno trasero
5	22.90053.000	1		Mozzetto	Hub	Moyeu	Nabe	Cubo
6	11.46251.000	2		Bullone flangiato M5x12	Head Flanged bolt M5x12	Boulon Bridé M5x12	Bundbolzen M5x12	Bulón con Brida M5x12
7	026.36.000.00.00	1		Molla ritorno pedale freno	Brake pedal spring	Ressort Pé dale Frein	Feder Fussbremspedal	Muelle pedal de freno
8	29.09428.000	1		Tubo Freno Posteriore	Rear brake tube	Tuyau du frein AR.	Hintere Bremsleitung	Tubo freno trasero
9	031.36.004.00.00	1		Tubo Freno Ant.	Front brake tube	Tuyau du frein AV.	Vordere Bremsleitung	Tubo freno delantero
10	11.65053.000	2		Bullone forato 10x1,25	Pierced bolt 10x1,25	Boulon avec trou 10x1,25	Bolzen 10x1,25	Tornillo 10x1,25
11	16.50510.000	6		Guarnizione 10x15x1 in rame	Gasket 10x15x1 copper	Joint 10x15x1 cuivre	Dichtung 10x15x1 Kupfer	Junta 10.15.1 (cobre)
12	27.49500.000	2		Rondella 8x18	Washer 8x18	Rondelle 8x18	U.Scheibe 8x18	Arandela 8x18
13	11.55690.000	2		Bullone M8x45 ch10 rs	Bolt M8x45 ch10 rs	Boulon M8x45 ch10 rs	Bolzen M8x45 ch10 rs	Tornillo M8x45 ch10 rs
14	18.89621.000	1		Interruttore stop	Stop switch	Interrupteur stop	Stopschalter	Interruptor stop
15	12.93388.000	2		Cuscinetto 8x22x7	Bearing 8x22x7	Roulement 8x22x7	Lager 8x22x7	Cojinete 8x22x7
16	27.49500.000	1		Rondella 8x18	Washer 8x18	Rondelle 8x18	U.Scheibe 8x18	Arandela 8x18
17	13.17020.000	1		Dado autoblocc. Basso M8	Nut M8	Ecrou M8	Mutter M8	Tuerca M8
18	31.63985.000	1		Vite TSPCE M8x50 CL 10.9	Screw TSPCE M8x50 CL 10.9	Vis TSPCE M8x50 CL 10.9	Schraube TSPCE M8x50 CL 10.9	Tornillo TSPCE M8x50 CL 10.9
19	25.41830.000	1		Forcellino	Clip	Ressort	Fixiergabel	Horquilla
20	12.81995.000	1		Copiglia 2x15	Split pin 2x15	Goupille 2x15	Splint 2x15	Grupilla 2x15
21	20.02717.000	1		Kit pistoncini e guarniz. Pinza	Piston e oil seal for pliers	Jeu petit pistons et joint pinces	Reparatursatz Bremszange	Juego piston y guarnicion pinza
22	31.96821.000	1		Grano	Dowel	Goujon	Stift	Clavija
23	25.41860.000	1		Perno ancoraggio pastiglia	Pin hanger	Pivot ancrage	Halter brehsbelage	Varilla esp. Pastillas pinzas
24	28.91002.000	1		Sfiato	Breather	Reniflard	Entlü fter	Respiradero
25	25.25362.000	1		Pastiglie freno post.	Rear brake pads	Pastill. de freins AR.	Hinterbremsbelag	Pastillas frenos tras.
26	020.36.011.00.00	1		Staffa supporto pinza	Caliper support bracket	Bride support é trier	Bremssattelbefestigung	Brida soporte pinza
27	22.32208.000	1		Molla ferma pastiglie pinza	Brake pads spring for pliers	Ressort arret plaquettes	Haltefeder	Muelle pastillas pinza
28	020.36.012.00.00	1		Staffa supporto pinza	Caliper support bracket	Bride support é trier	Bremssattelbefestigung	Brida soporte pinza
29	25.25361.000	1		Pastiglie freno ant.	Front brake pads	Pastill. de freins AV.	Vorderbremsbelag	Pastillas frenos del.
30	22.32207.000	1		Molla ferma pastiglie pinza	Brake pads spring for pliers	Ressort arret plaquettes	Haltefeder	Muelle pastillas pinza
31	25.41859.000	1		Perno ancoraggio pastiglia	Pin hanger	Pivot ancrage	Halter brehsbelage	Varilla esp. Pastillas pinzas
32	31.96821.000	1		Grano	Dowel	Goujon	Stift	Clavija
33	20.02716.000	1		Kit pistoncini e guarniz. Pinza	Piston e oil seal for pliers	Jeu petit pistons et joint pinces	Reparatursatz Bremszange	Juego pistón y guarnicion pinza
34	28.91001.000	1		Sfiato	Breather	Reniflard	Entlü fter	Respiradero
35	20.08276.000	1		Kit pistoncino pompa post.	Piston kit rear master cyl.	Kit piston. maî tre cyl. AR.	Kolbensatz hinterhauptbremszylinder	Kit pistón bomba tras.
36	31.30750.000	2		Vite M6x16	Screw M6x16	Vis M6x16	Schraube M6x16	Tornillo M6x16
37	20.08277.000	2		Kit leva	lever kit	Jeu levier	Hebelsatz	Juego palanca
38	20.08275.000	1		Kit serbatoio pompa	Kit, pump tank	Kit reservoir pompe	Deckel pumpstake	Kit deposito bomba
40	036.36.002.00.00	1		Protezione	Protection	Protection	Schutzstü ck	Protecció n
41	036.36.003.00.00	1		Protezione	Protection	Protection	Schutzstü ck	Protecció n
42	036.36.006.82.00	1		Kit protezioni anteriore	Font protections kit	Jeu protections avant	Kit Vorne Schutzstü ck	Juego protecció nes delanteras
43	036.36.004.00.00	1		Protezione	Protection	Protection	Schutzstü ck	Protecció n
44	036.36.005.00.00	1		Protezione	Protection	Protection	Schutzstü ck	Protecció n
45	036.36.007.82.00	1		Kit protezioni posteriore	Rear protections kit	Jeu protections arriè re	Kit Hintere Schutzstü ck	Juego protecció nes traseras

Tav.37

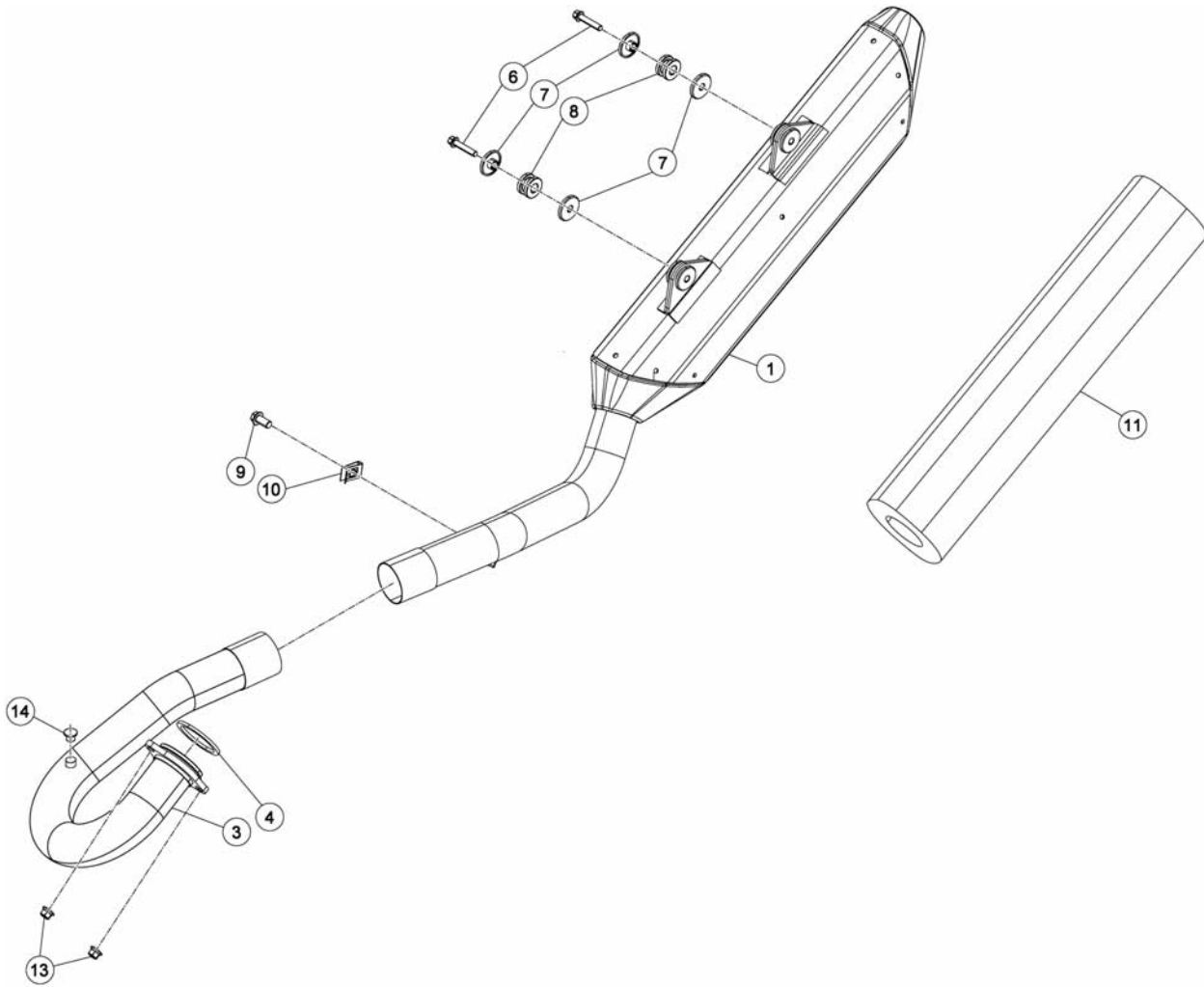

Pos Loc Pos Ps Pos	Numero Number Numéro Número Nummer	Q.tà Q.ty Q.té M.ge C.ad	Nota Note Note Nota Anm.	Descrizione	Description	Dé signation	Beschreibung	Descrìpiò n
1	031.37.034.80.00	1		Silenziatore	Silencer	Silencieux	Endschalldämpfer	Silenciador
3	031.37.038.00.00	1	350-390cc	Collettore di scarico	Exhaust manifold	Collecteur d' échapp.	Abgaskrü mmer	Colector de escape
3	031.37.009.00.00	1	430-500cc	Collettore di scarico	Exhaust manifold	Collecteur d' échapp.	Abgaskrü mmer	Colector de escape
4	020.37.004.00.00	1		Guarnizione scarico	Exhaust manifold gasket	Joint coll. Ech.	Dichtung Abgaskrü mmer	Junta colector de escape
6	11.50300.000	2		Bullone 6x30 ch rs	Bolt 6x30 ch rs	Boulon 6x30 ch rs	Bolzen 6x30 ch rs	Tornillo 6x30 ch rs
7	13.49187.000	4		Scodellino	Stop washer	Rondelle d' ar	Federaufnahme	Platillo
8	28.91946.000	2		Silentbloc	Silentbloc	Silentbloc	Puffer	Silent-block
9	11.48025.000	1		Vite M6x16 RS CH8	Screw M6x16 RS CH8	Vis M6x16 RS CH8	Schraube M6x16 RS CH8	Tornillo M6x16 RS CH8
10	25.60311.000	1		Piastrina elastica M6	Spring plate M6	Plaqueette é lastique M6	Plättchen M6	Pletina elástica M6
11	020.37.099.80.00	1		Kit revisione silenziatore	Kit for silencer overhauling	Kit ré v. Silencieux	Reparatursatz Schalldämpfer	Kit revisión silenciador
13	13.17121.000	2		Dado speciale M8	Special nut M8	Ecrou spéciale M8	Spezialmutter M8	Tuerca especial M8
14	031.37.030.00.00	1		Tappo sensore ossigeno	Oxygen sensor plug	Bouchon sonde oxygene	Verschluss Lambdasonde	Tapó n sensor oxigeno

Tav.38

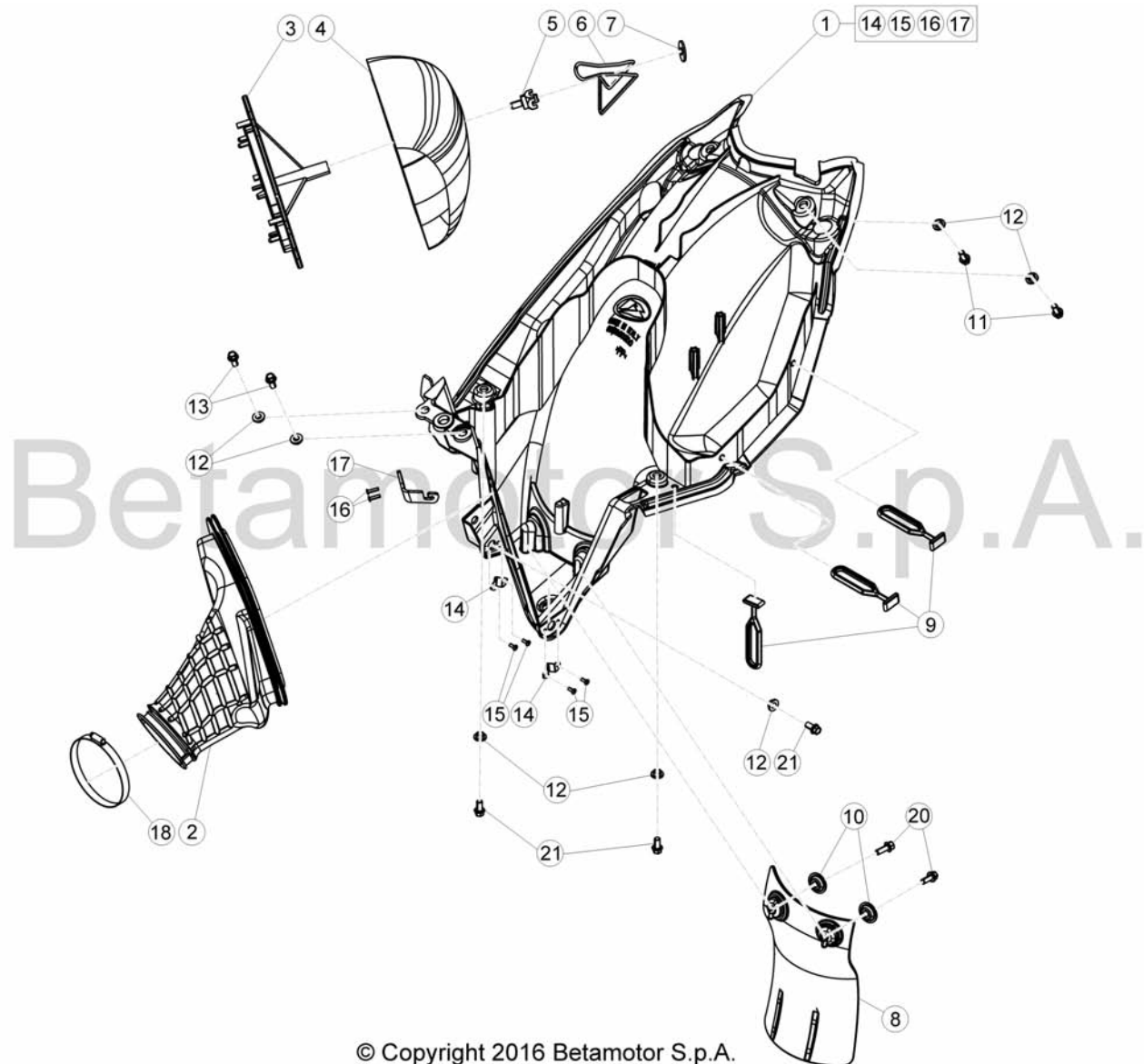

© Copyright 2016 Betamotor S.p.A.

Pos	Numero	Q.tà	Nota	Descrizione	Description	Dé signation	Beschreibung	Descripció n
Loc	Number	Q.ty	Note					
Pos	Numé ro	Q.té	Note					
Ps	Nú mero	M.ge	Nota					
Pos	Nummer	C.ad	Anm.					
1	031.38.009.80.59	1		Scatola filtro completa	Air cleaner box	Boî tier filtre à air	Luftfiltergehä use	Caja filtro de aire
2	031.38.003.00.00	1		Manicotto scatola filtro	Filter box sleeve	Manchon boî te du filtre	Filtergehä usemuffe	Manguito caja filtro
3	031.38.002.00.00	1		Gabbia filtro aria	Filter cage	Grille filtre aire	Filter kafig	Jaula filtro aire
4	031.38.001.00.00	1		Filtro aria	Air filter	Filtere à air	Luftfilter	Filtro de aire
5	25.57197.000	1		Perno richiamo ferma-filtro	Filter pin	Pivot filtre	Filtershalter	Pin Eje filtro
6	020.38.021.00.00	1		Molla fermafiltro	Filter spring	Ressort filtre	Filter Feder	Muelle filtro
7	27.74800.000	1		Rondella autobloccante 9	Washer 9	Rondelle 9	Scheibe 9	Arandela 9
8	026.38.007.10.59	1		Protezione ammortizzatore	Rear damper protection	Protection amortisseur	Stosdä mpferschutz	Protecció n amortiguador
9	16.34907.000	3		Gommino	Rubber buffer	Caoutchouc	Gummi	Goma
10	27.74786.000	2		Rondella bombata	Kasher	Rondelle	Scheibe	Arandela
11	31.79960.000	2		Vite autofilettante 6x15	Self tapping screw 6x15	Vis taraud 6x15	Schraube, Blech 6x15	Tornillo autorrosc. 6x15
12	13.54820.000	7		Distanziale 6,5x9,0x13,5	Spacer 6,5x9,0x13,5	Entretoise 6,5x9,0x13,5	Distanzstü ck 6,5x9,0x13,5	Distanciador 6,5x9,0x13,5
13	11.47015.000	2		Bullone M6x12	Bolt M6x12	Boulon M6x12	Bolzen M6x12	Tornillo M6x12
14	026.38.004.00.00	2		Ricettacolo	Receptacle	Rè ceptacle	Behä lter	Receptaculo
15	C18.19.009.00.00	4		Rivetto a strappo 2,4x8 all.	Rivet 2,4x8	Rivet 2,4x8	Niet 2,4x8	Remache 2,4x8
16	27.33742.000	2		Rivetto a strappo 3x12	Rivet 3x12	Rivet 3x12	Niet 3x12	Remache 3x12
17	020.38.002.00.00	1		Staffa	Bracket	Bras	Halterung	Brida
18	15.14606.000	1		Fascetta	Clamp	Collier	Schelle	Abrazadera
20	31.30815.000	2		Vite autofilettante 6x20	Self tapping screw 6x20	Vis taraud 6x20	Schraube, Blech 6x20	Tornillo autorrosc. 6x20
21	11.48025.000	3		Bullone 6x16 ch 8 rs	Bolt 6x16 ch 8 rs	Boulon 6x16 ch 8 rs	Bolzen 6x16 ch 8 rs	Tornillo 6x16 ch 8 rs

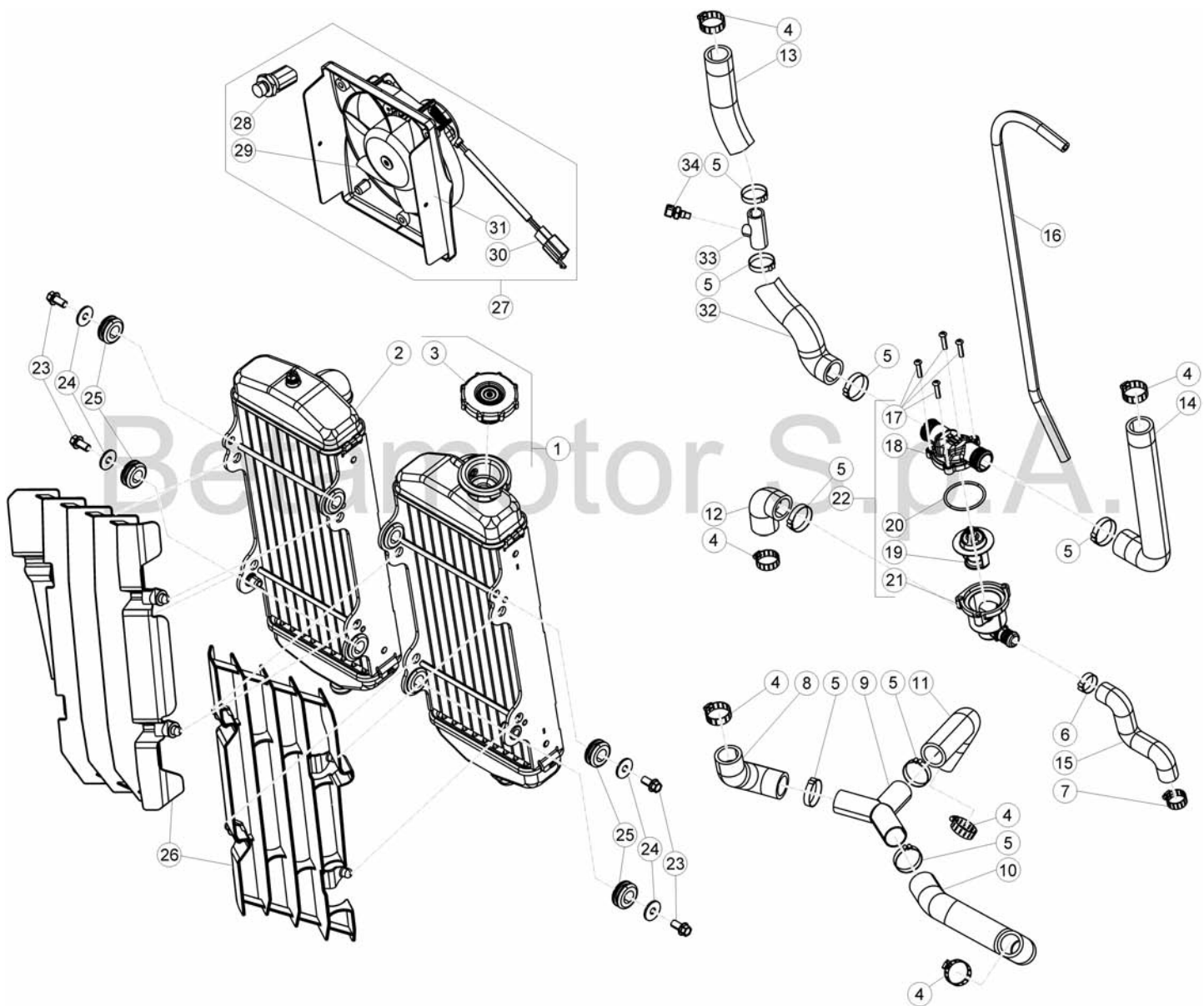

© Copyright 2017 Betamotor S.p.A.

Tav.39

Pos Loc Ps Pos	Numero Number Numéro Número Nummer	Q.tà Q.ty Q.té M.ge C.ad	Nota Note Note Nota Anm.	Descrizione	Description	Dé signation	Beschreibung	Descrìpziò n
1	020.39.110.00.00	1		Radiatore Sx	L.H. radiator	Radiateur G.	L., Kühler	Radiador iz.
2	020.39.021.00.00	1		Radiatore Dx	R.H. radiator	Radiateur D.	R., Kühler	Radiador der.
3	020.39.111.00.00	1		Tappo radiatore	Radiator plug	Bouchon radiateur	Kühlerdeckel	Tapa de radiador
4	15.15240.000	6		Fascetta 19/28	Clamp 19/28	Collier 19/28	Schelle 19/28	Abrazadera 19/28
5	020.39.008.00.00	8		Fascetta 24	Clamp 24	Collier 24	Schelle 24	Abrazadera 24
6	020.39.009.00.00	1		Fascetta 17	Clamp 17	Collier 17	Schelle 17	Abrazadera 17
7	15.15220.000	1		Fascetta 12/22	Clamp 12/22	Collier 12/22	Schelle 12/22	Abrazadera 12/22
8	031.39.005.00.00	1		Tubo radiatore dx	R.H. radiator tube	Tube radiateur d.	Wasserschlauch Kühler re.	Tubo radiador derecho
9	020.39.020.00.00	1		Raccordo a Y	Y joint.p.	Raccord a Y	Y Stutzen	Racor a Y
10	031.39.023.00.00	1		Tubo radiatore sx.	L.H. radiator tube	Tube radiateur g.	Wasserschlauch Kühler li.	Tubo radiador izquierdo
11	031.39.007.00.00	1		Tubo pompa acqua	Water pump pipe	Tube pompe eau	Leitung wasserpumpe	Tubo bomba agua
12	020.39.001.00.00	1		Tubo termostato radiatore dx.	Thermostat hose R.H.	Tube interrupteur thermique	Thermostatschlauch	Tubo termostato
13	031.39.025.14.00	1		Tubo radiatore	Radiator tube	Tube radiateur	Wasserschlauch Kühler	Tubo radiador
14	020.39.003.00.00	1		Tubo termostato radiatore sx.	Thermostat hose L.H.	Tube interrupteur thermique	Thermostatschlauch	Tubo termostato
15	020.39.002.00.00	1		Tubo termostato inf. sx.	Thermostat hose L.H. lower	Tube interrupteur thermique inf. g	Thermostatschlauch unten links	Tubo termostato inf. izq.
16	020.39.015.00.00	1		Tubo sovrappressione	Overpressure hose	Tuyau surpression	Kühlerschlauch Überdruck	Tubo sobre presión
17	031.39.017.50.00	4		Vite speciale M3,5X18	Special screw M3,5X18	Vis spéciale M3,5X18	Spezialschraube M3,5X18	Tornillo especial M3,5X18
18	031.39.016.00.00	1		Coperchio termostato	Thermostat cover	Couvercle du thermostat	Thermostatabdeckung	Tapa del termostato
19	020.39.013.00.00	1		Termostato	Bimetal, thermostatic	Thé rmostat	Thermostat	Termostato
20	10.66830.000	1		Anello or 32.2	O-Ring 32.2	Bague d' é tanché ité 32.2	O-Ring 32.2	Anillo OR 32.2
21	031.39.015.00.00	1		Contentitore termostato	Thermostat container	Logement interrupteur thermique	Rahmen Thermostatschlauch	Plástico termostato
22	031.39.014.80.00	1		Termostato completo	Thermostat, assy	Thermostat complet	Thermostat komplett	Termostato compl.
23	11.47015.000	4		Bullone M6x12	Bolt M6x12	Boulon M6x12	Bolzen M6x12	Tornillo M6x12
24	27.43250.000	4		Rondella 6x24	Washer 6x24	Rondelle 6x24	U.Scheibe 6x24	Arandela 6x24
25	16.34911.000	4		Gommino	Rubber buffer	Caoutchouc	Gummi	Goma
26	031.39.003.00.51	1		Coppia griglie radiatore	Pair radiator grills	Couple calandres	Kühlergrillpaar	Par rejas del radiador
27	031.46.024.82.00	1		Kit elettroventola	Electric fan kit	Jeu electro-ventilateur	Elektroluterradsatz	Kit electroventilador
28	020.40.007.00.00	1		Termointerruttore	Thermal switch	Thermo-régulateur	Umschalter	Interruptor té rmico
29	14.01040.000	1		Elettroventola	Electric fan	Electro-ventilateur	Elektroluterrad	Electroventilador
30	18.01596.000	1		Impianto elettroventola	Electric fan system	Circuit electro-ventilateur	Anlage Elektroluterrad	Instalacion electroventilador
31	031.39.013.15.00	2		Supporto elettroventola	Heater fan support	Support electro-ventilateur	Halterung Elektroluterrad	Soporte electroventilador
32	031.39.026.14.00	1		Tubo termostato	Thermostat hose	Tube interrupteur thermique	Thermostatschlauch	Tubo termostato
33	031.39.020.00.00	1		Raccordo a T	T joint.p.	Raccord a T	T Stutzen	Racor a T
34	031.40.032.00.00	1		Sensore temperatura	Temperature sensor	Capteur de température	Temperaturfühler	Sensor de temperatura

GR. COMPONENTI ELETTRICI/CABLAGGI

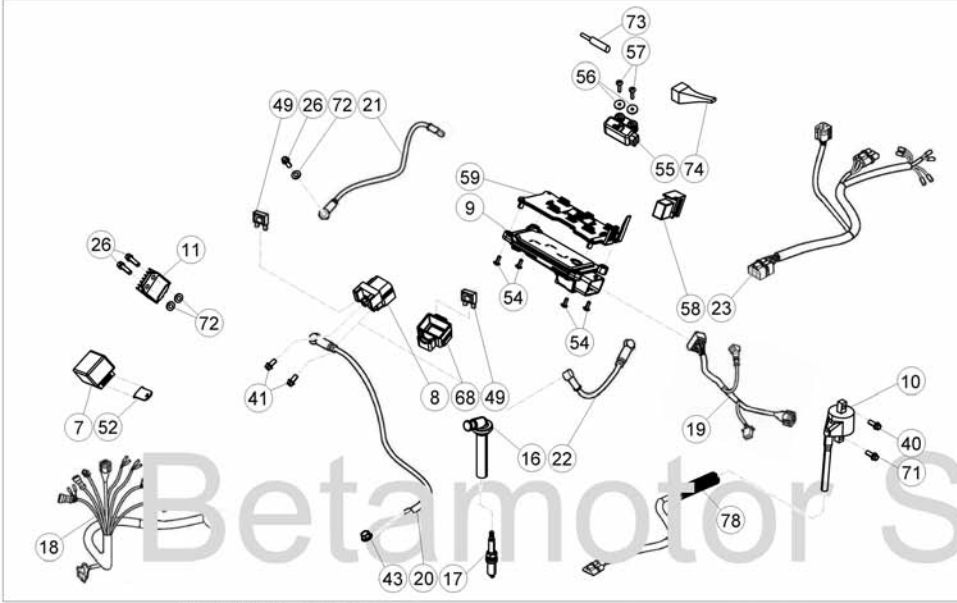

GR. STRUMENTAZIONE

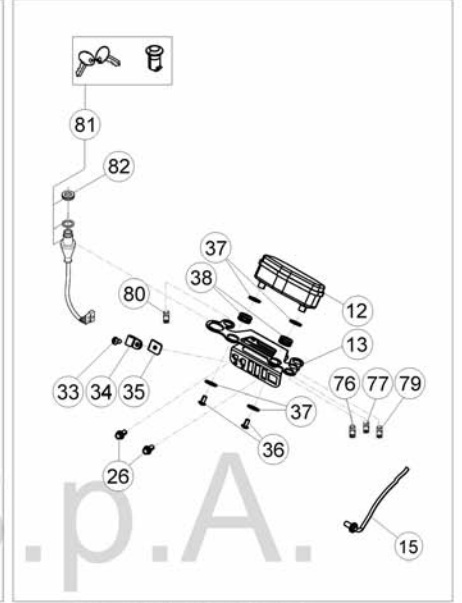

GR. LUCI/INDICATORI

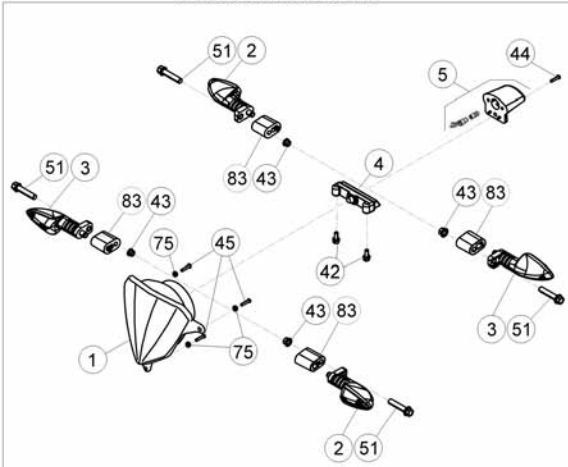

GR. AVV. ACUSTICO

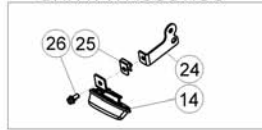

GR. ACCESSORI

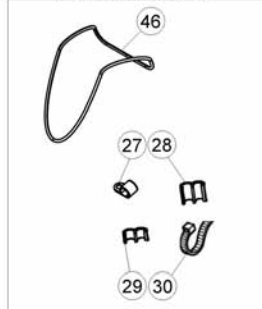

GR. POMPA CARBURANTE

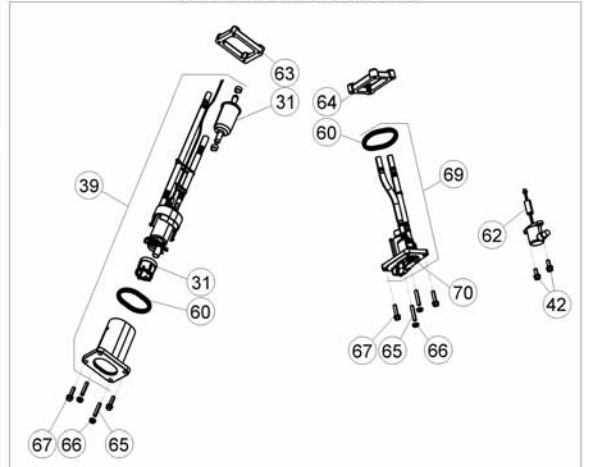

© Copyright 2017 Betamotor S.p.A.

Tav.40

Pos Loc Pos Ps Pos	Numero Number Numéro Nummer	Q.tà Q.ty Q.té M.ge C.ad	Nota Note Nota Anm.	Descrizione	Description	Dé signation	Beschreibung	Descrìpziò n
1	16.46210.800	1		Gruppo ottico	Headlamp	Projecteur	Scheinwerfer	Faro del.
2	18.12691.000	2		Indicatore dir. ant. sx.-post. Dx	Turn signal L.H.front-R.H.rear	Clignotant av.g.-ar.dr.	Blink. Vorderer links-Hinterer rechts	Indicador del. izq.-tras. der.
3	18.12681.000	2		Indicatore dir. ant. dx.-post. Sx	Turn signal R.H.front-L.H.rear	Clignotant av.dr.-ar.g.	Blink.Vorderer rechts-Hinterer links	Indicador del. der.-tras. izq.
4	15.01769.800	1		Fanalino posteriore a led	LED tail lamp	Feu AR. à diodes	LED-Rücklicht	Piloto a LED
5	020.40.020.00.00	1		Luce Targa	Plate illumination	Éclairage De Plaque	Kennzeichen-Beleuchtung	Iluminació n Placa
7	18.84946.000	1		Intermittenza	Unit turn signal lamps	Disp. comm. clignot.	Blinkgeber	Disp. intermitentes
8	27.28471.000	1		Relais	Relay	Relais	Relay	Relé
9	031.40.015.10.00	1		Centralina digitale da programmare	Unprogrammed CDI unit	Bobine digital (C.D.I.) à programmer	Unprogrammierten CDI-Einheit	Centralita digital no programada
10	031.40.021.37.00	1		Bobina accensione	Ignition coil	Bobine allumage	Zuendspule	Bobina de encendido
11	031.40.025.37.00	1		Regolatore	Regulator	Régulateur	Regler	Regulador
12	031.40.030.00.00	1		Strumento digitale	Digital instrument	Instrument numérique	Digitalinstrument	Instrumento digital
13	031.40.059.22.00	1		Supporto strumento	Instrument holder	Support instruments	Instrumentenhalter	Soporte instrumentos
14	007.40.050.00.00	1		Avvisatore acustico	Warning horn	Avertisseur sonore	Hupe	Claxon
15	28.79013.000	1		Sensore REED	REED sensor	Sensor REED	Sensor	Sensor REED
16	006.10.055.00.00	1		Cappuccio candela	Spark plug cap	Capuchon/couvercle bougie	Zündkerzenkappe	Capuchón de la bujía
17	006.10.050.00.00	1		Candela M12X1,25	Spark plug M12X1,25	Bougie M12X1,25	Zündkerze M12X1,25	Bujía M12X1,25
18	031.40.004.00.00	1		Impianto servizi anteriore	Front wire harness for services	Installation avant services	Vorderer Kabelbaum	Cableado delantero servicios
19	031.40.130.80.00	1		Impianto principale completo	Main wire harness	Cablage principal complet	Kabeleinheit komplett	Conjunto cables principal
20	031.40.038.00.00	1		Cavetto relè avviamento	Starter relay cable	Cable relais de demarrage	Anlassrelaiskabel	Cable relé de arranque
21	036.40.011.00.00	1		Cavetto di massa	Ground cable	Cable masse	Masse kabel	Cable masa
22	020.40.003.00.00	1		Cavo batteria-relè	Battery-Relay cable	Cable batterie-relais	Kabel Batterie-Relais	Cable Batería-Relé
23	031.40.042.00.00	1		Impianto posteriore	Rear harness	Circuit post.	Anlage hinten	Instalación tras.
24	28.97255.000	1		Staffa supporto claxon	Horn support bracket	Bride support avertisseur	Hupebefestigung	Brida soporte claxon
25	25.60311.000	1		Piastrina elastica M6	Spring plate M6	Plaquette élastique M6	Plättchen M6	Pletina elástica M6
26	11.47015.000	6		Bullone M6x12	Bolt M6x12	Boulon M6x12	Bolzen M6x12	Tornillo M6x12
27	15.14654.000	1		Fascetta	Clamp	Collier	Schelle	Abrazadera
28	25.24442.000	1		Passacavo 6/8	Fair lead 6/8	Passe-fils 6/8	Kabelführung 6/8	Pasa-cable 6/8
29	25.24443.000	3		Passacavo 6/6	Fair lead 6/6	Passe-fils 6/6	Kabelführung 6/6	Pasa-cable 6/6
30	15.14264.000	1		Fascetta	Clamp	Collier	Schelle	Abrazadera
31	031.40.043.82.00	1		Kit filtri pompa benzina	Fuel pump filters kit	Jeu filtres pompe carburant	Bausatz Benzinpumpenfilter	Kit filtros bomba gasolina
33	31.23530.000	1		Vite M4,2x16 TMTIC	Screw M4,2x16 TMTIC	Vis M4,2x16 TMTIC	Schraube M4,2x16 TMTIC	Tornillo M4,2x16 TMTIC
34	25.25182.000	1		Fascetta	Clamp	Collier	Schelle	Abrazadera
35	25.58090.000	1		Piastrina elastica	Spring plate	Plaquette élastique	Plättchen	Pletina elástica
36	31.27500.000	2		Vite M4x16 TCIC	Screw M4x16 TCIC	Vis M4x16 TCIC	Schraube M4x16 TCIC	Tornillo M4x16 TCIC
37	020.40.812.00.00	4		Distanziale 5x15	Spacer 5x15	Entretoise 5x15	Distanzstück 5x15	Distanciador 5x15
38	031.40.013.00.00	2		Gommino	Rubber buffer	Caoutchouc	Gummi	Goma
39	031.40.024.00.00	1		Pompa benzina	Fuel pump	Pompe carburant	Benzinpumpe	Bomba gasolina
40	11.49070.000	1		Bullone 6x20 ch rs	Bolt 6x20 ch rs	Boulon 6x20 ch rs	Bolzen 6x20 ch rs	Tornillo 6x20 ch rs
41	31.30190.000	2		Vite a brugola 6x8	Allen screw 6x8	Vis à 6 pans 6x8	Sechskantschraube 6x8	Tornillo a llave allen 6x8
42	11.46251.000	4		Bullone flangiato M5x12	Head Flanged bolt M5x12	Boulon Bridé M5x12	Bundbolzen M5x12	Bulón con Brida M5x12
43	13.12550.000	5		Dado flangiato M6	Flanged nut M6	Ecrou bordé M6	Flanschmutter M6	Tuerca embreada M6
44	31.23565.000	1		Vite 4,5x15 TCCCR	Screw 4,5x15 TCCCR	Vis 4,5x15 TCCCR	Schraube 4,5x15 TCCCR	Tornillo 4,5x15 TCCCR
45	31.26190.000	3		Vite M4x12 TCIC	Screw M4x12 TCIC	Vis M4x12 TCIC	Schraube M4x12 TCIC	Tornillo M4x12 TCIC
46	14.40020.000	1		Cinghia fiss. batteria	Battery sec. strap	Bande fix. batterie	Batteriebefestigung Riemen	Correa suj. batería
49	020.40.006.00.00	6		Fusibile 10A	Fuse 10A	Fusible 10A	Sicherung 10A	Fusible 10A
51	11.05540.000	4		Bullone 6x55 ch 8 rs	Bolt 6x55 ch 8 rs	Boulon 6x55 ch 8 rs	Bolzen 6x55 ch 8 rs	Tornillo 6x55 ch 8 rs
52	031.40.002.22.00	1		Staffa intermittenza	Flasher bracket	Support intermitence	Platte Blinkgeber	Placa soporte intermitencia
54	31.23370.000	4		Vite M4x11 TTLIC	Screw M4x11 TTLIC	Vis M4x11 TTLIC	Schraube M4x11 TTLIC	Tornillo M4x11 TTLIC
55	031.40.017.00.00	1		Sensore antiribaltamento	Tilt sensor	Captteur d'inclinaison	Neigungssensor	Sensor de inclinación
56	27.34800.000	2		Rondella grower 4x16	Grower washer 4x16	Rondelle Grower 4x16	Federring Grower 4x16	Arandela elástica Grower 4x16
57	31.23560.000	2		Vite autofilettata 4,2x25 TMTIC	4,2x25 TMTIC	4,2x25 TMTIC	4,2x25 TMTIC	4,2x25 TMTIC
58	031.40.039.00.00	1		Relè centralina	Electronic control unit relay	Relais unité de commande	Zündboxrelais	Relé centralita
59	031.40.016.10.00	1		Piastrina fissaggio centralina	ECU fastening plate	Plaquette de fix. unité de comm.	Befestigungsblech Zündbox	Placa sujeción centralita
60	031.40.044.82.00	1		Kit guarnizioni	Packings kit	Jeu joints	Dichtungensatz	Grupo juntas
62	031.40.014.00.00	1		Sonda segnalazione riserva	Low fuel sensor	Sonde niveau ré serve	Sonde zur Reserveanzeige	Sonda señalación reserva
63	031.43.087.00.00	1		Piastra con gomma vulcanizzata	Plate with vulcanized rubber	Plaque avec caoutchouc vulcanisé	Platte mit Kautschukvulkanisat	Placa con goma vulcanizada
64	031.43.090.00.00	1		Piastra con gomma vulcanizzata	Plate with vulcanized rubber	Plaque avec caoutchouc vulcanisé	Platte mit Kautschukvulkanisat	Placa con goma vulcanizada
65	C24.75.002.00.00	4		Prigioniero M5 L.22	Stud M5 L.22	Goujon M5 L.22	Stiftschraube M5 L.22	Espárrago M5 L.22
66	C24.07.013.00.00	4		Dado autobloccante flangiato M5	Self locking nut, flanged M5	Ecrou de sécurité bordé M5	Mutter, selbstsichernd M5	Tuerca de seguridad embreada M5
67	11.46401.000	4		Bullone M5x20	Bolt M5x20	Boulon M5x20	Bolzen M5x20	Tornillo M5x20
68	031.40.018.10.00	1		Elastico	Rubber band	Elastique	Gummi band	Elastico
69	031.40.045.00.00	1		Kit regolatore	Regulator kit	Jeu régulateur	Bausatz Regler	Juego regulador

GR. COMPONENTI ELETTRICI/CABLAGGI

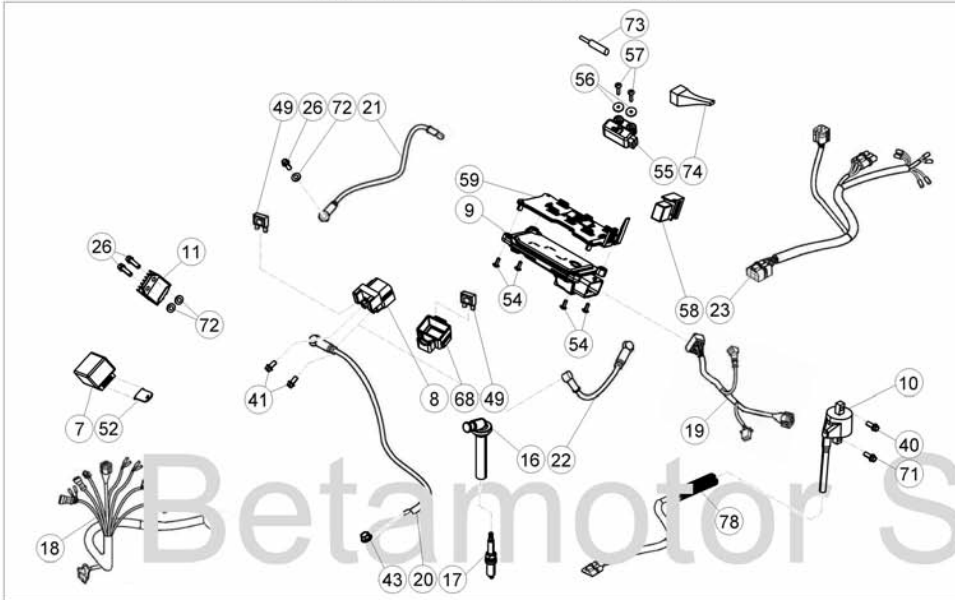

GR. STRUMENTAZIONE

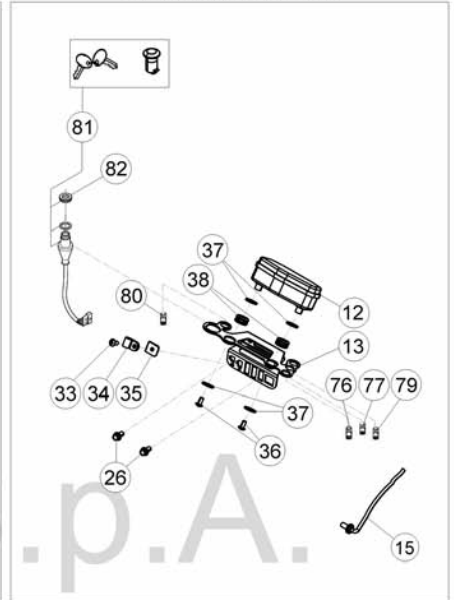

GR. LUCI/INDICATORI

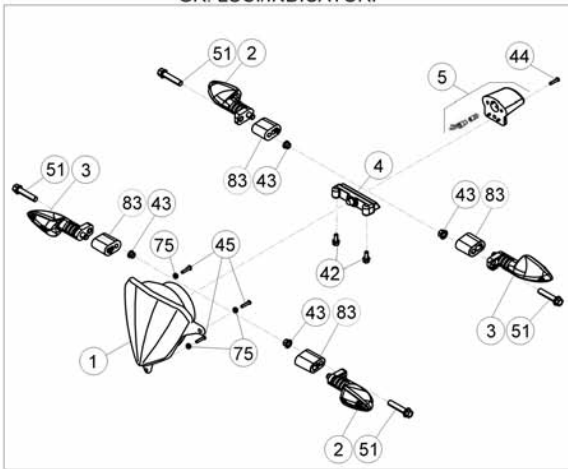

GR. AVV. ACUSTICO

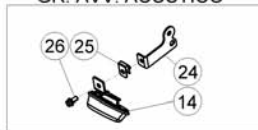

GR. ACCESSORI

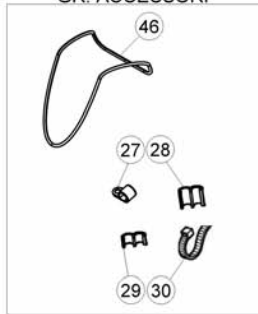

GR. POMPA CARBURANTE

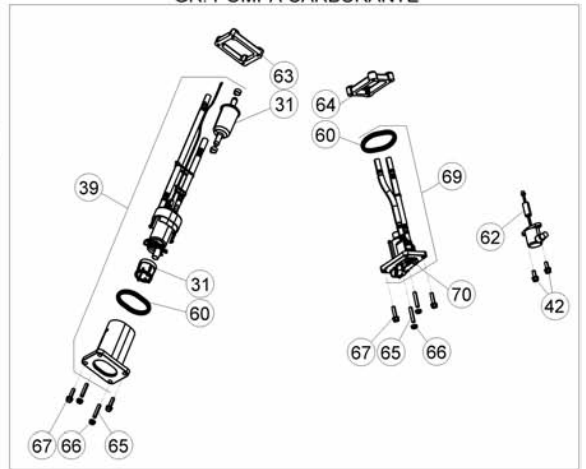

© Copyright 2017 Betamotor S.p.A.

Tav.40

Pos Loc Pos Ps Pos	Numero Number Numéro Número Nummer	Q.tà Q.ty Q.té M.ge C.ad	Nota Note Note Nota Anm.	Descrizione	Description	Désignation	Beschreibung	Descripción
70	031.40.049.82.00	1		Kit raccordo carburante	Fuel union kit	Jeu raccord carburant	Bausatz Anschluss Kraftstoffschlauch	Empalme carburante
71	11.50010.000	1		Bullone M6x25	Bolt M6x25	Boulon M6x25	Bolzen M6x25	Tornillo M6x25
72	27.40500.000	3		Rondella	Washer	Rondelle	U.Scheibe	Arandela
73	031.40.051.00.00	1		Condensatore	Condenser	Condensateur	Kondensator	Condensador
74	031.40.052.00.00	1		Gruppo diodi	Diode gr.	Groupe diodes	Diodeinheit	Grupo diodos
75	27.34650.000	3		Rondella 4x9	Washer 4x9	Rondelle 4x9	U.Scheibe 4x9	Arandela 4x9
76	28.92897.000	1		Spia luce abbagliante	Headlight tell tale lamp	Té moin phare	Fernlichtkontrollampe	Testigo luz de carretera
77	28.92895.000	1		Spia lampeggiatori	Trafficator lights tell tale lamp	Té moin clignotants	Bü nkllichtkontrollampe	Indicador luces intermitentes
78	031.40.033.00.00	1		Sensore contagiri	Tachometer sensor	Capteur compte-tours	Drehzählersensor	Sensor cuenta-revoluciones
79	031.40.056.00.00	1		Spia malfunzionamento iniezione	Clutch malfunction warning light	Té moin de panne de l' embayage	Kontrollampe Kupplung funktionsstö rungen	Indicador mal funcionamiento embrague
80	031.40.057.00.00	1		Spia riserva	Fuel level warning light	Té moin d' essence	Reserve Kontrollampe	Indicador de reserva
81	12.55291.000	1		Commutat.c/chiavi e b/sterzo	Key operated switch	Commutateur à clef	Zuendschloss	Commutador c/llaves y b/volante
82	16.20640.000	1		Ghiera commutatore	Commutator grill	Grille commutateur	O-ring zuendschloss	Junta conmutador
83	031.40.128.00.59	4		Distanziale	Spacer	Entretoise	Distanzstü ck	Distanciador

Tav.41

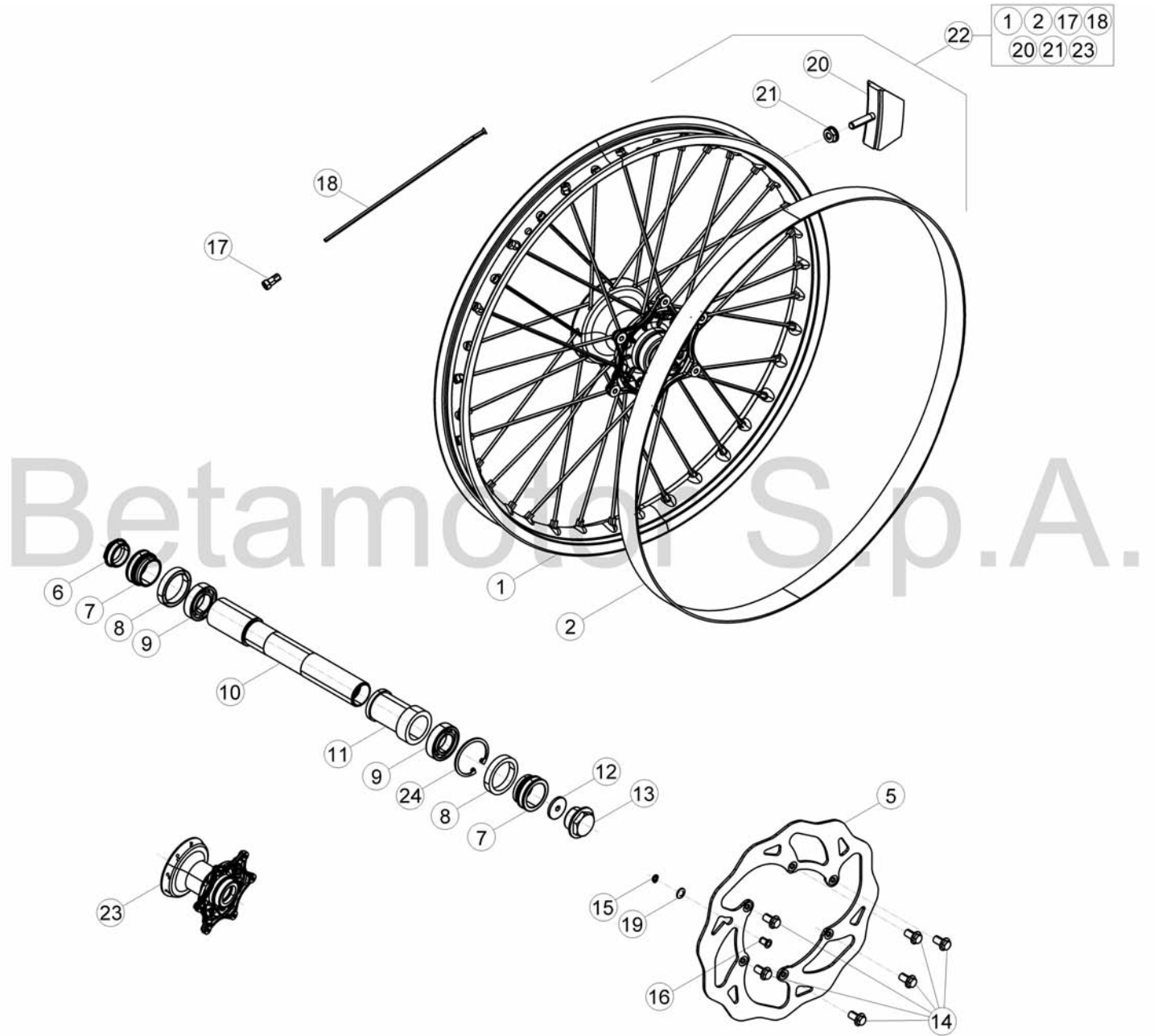

© Copyright 2016 Betamotor S.p.A.

Tav.41

Pos Loc Pos Ps Pos	Numero Number Numéro Nummer	Q.tà Q.ty Q.té M.ge C.ad	Nota Note Note Nota Anm.	Descrizione	Description	Dé signation	Beschreibung	Descrìpziò n
1	031.41.046.00.52	1		Cerchio anteriore 21x1,6	Front rim 21x1,6	Jante avant 21x1,6	Vorderfelge 21x1,6	Llanta delantera 21x1,6
2	15.38200.000	1		Flap 21x25	Bead 21x25	Flap21x25	Felgenband 21x25	Flap cinta tapa radios 21.25
5	031.41.030.00.00	1		Disco freno	Brake plate	Disque frein	Bremscheibe	Disco freno
6	020.41.007.00.00	1		Tappo perno ruota anteriore	Front wheel pin plug	Bouchon pivot roue avant	Stopfen Pin Vorrad	Tapó n eje rueda anterior
7	031.41.004.00.00	2		Distanziale ant.	Front spacer	Entretoise AV.	Distanzstück vorderer	Distanciadòr del.
8	10.66000.000	2		Paraolio 35x47x7	Oil seal 35x47x7	Pare-huile 35x47x7	Dichtring 35x47x7	Sello de lub. 35x47x7
9	020.41.003.00.00	2		Cuscinetto 30x47x9	Bearing 30x47x9	Roulement 30x47x9	Lager 30x47x9	Cojinete 30x47x9
10	020.41.005.00.00	1		Perno ruota anteriore	Front wheel spindle	Pivot roue AV.	Vorderradzapfen	Perno rueda delantera
11	031.41.015.00.00	1		Distanziale interno	Inner spacer	Entretoise interne	Innere Distanzstück	Distanciadòr interior
12	020.41.110.00.00	1		Tappo interno perno ruota anteriore	Front wheel inside pin plug	Bouchon intè rieur pivot roue avant	Innerhalb Stopfen Pin Vorrad	Tapó n interior eje rueda anterior
13	020.41.006.00.00	1		Tappo filettato	Threaded plug	Bouchon fileté	Gewindepfropf	Tapó n filete
14	031.41.016.00.00	6		Vite TEF M6x14	Screw TEF M6x14	Vis TEF M6x14	Schraube TEF M6x14	Tornillo TEF M6x14
15	28.22660.000	1		Seeger 9E	Circlip 9E	Circlip 9E	Seeger 9E	Seeger 9E
16	021.41.005.00.00	1		Magnete	Sensor magneto	Magneto capteur	Magnet für Sensor	Magneto sensor
17	031.41.050.00.00	36		Nipplo	Nipple	Ecrou	Nippel	Tuerca
18	031.41.049.00.52	36		Raggio	Spoke	Rayon	Speiche	Radio
19	27.58080.000	1		Rondella spessore	Shim	Rondelle entretoise	Ausgleichscheibe	Arandela suplemento
20	036.41.010.00.00	1		Fermacopertone	Tyre retainer	Arrêt	Felgenhalterung	Sujeta cobertura
21	13.17120.000	1		Dado M8 flangiato	Nut M8	Ecrou M8	Mutter M8	Tuerca M8
22	026.41.001.00.52	1		Ruota anteriore	Fr.wheel	Roue AV.	Vorderrad	Rueda delantera
23	031.41.014.80.00	1		Mozzo anteriore c/cuscinetti	Front hub with ballbearing	Moyeu avant avec roulements	Nabe vo.	Buje ant.c/cojinetes
24	C01.26.001.00.00	1		Seeger 47x1,75	Circlip 47x1,75	Circlip 47x1,75	Seeger 47x1,75	Seeger 47x1,75

Tav.42

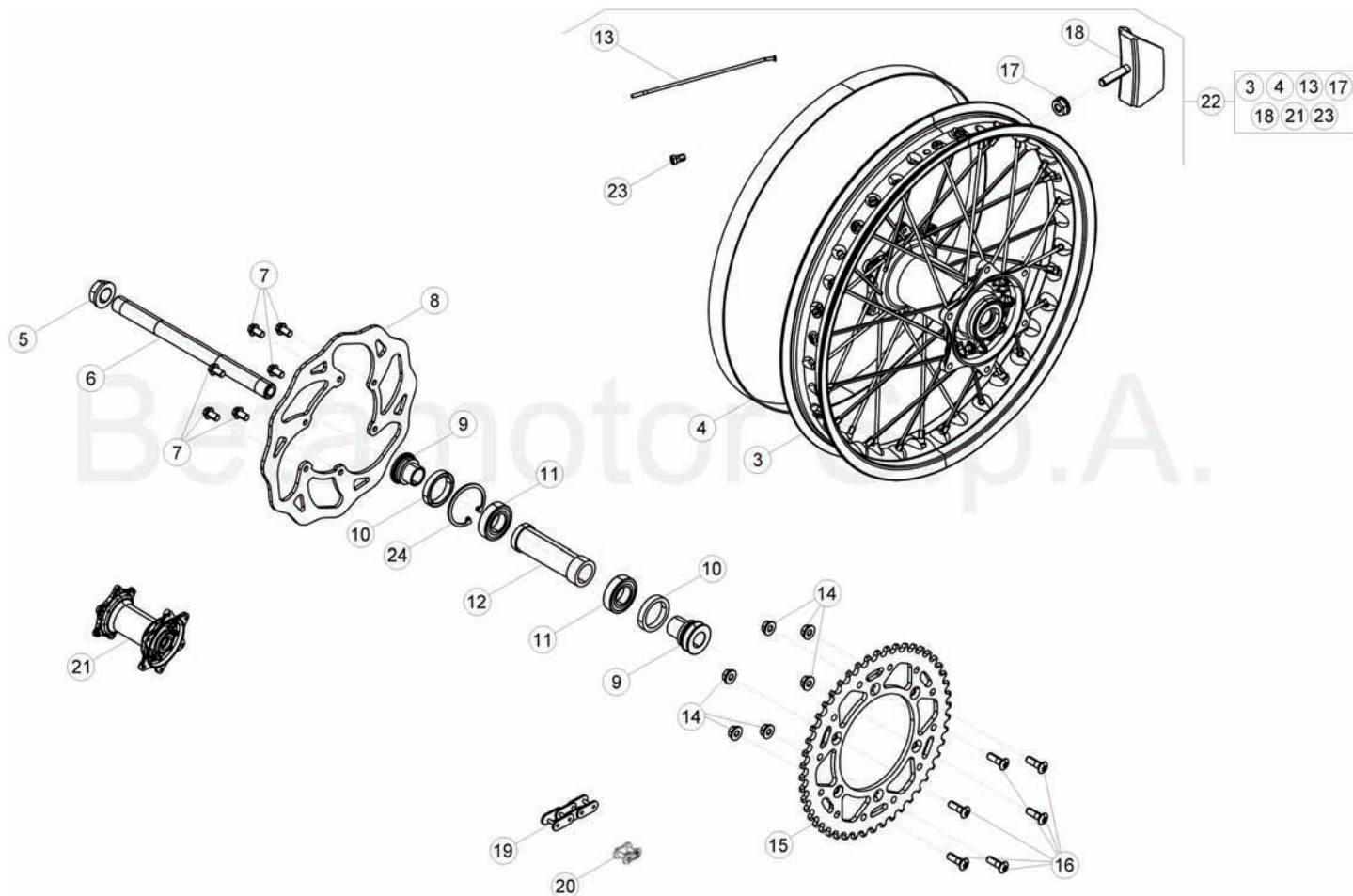

© Copyright 2017 Betamotor S.p.A.



Beta
motorcycles

Tav.42

Pos Loc Pos Ps Pos	Numero Number Numé ro Número Nummer	Q.tà Q.ty Q.té M.ge C.ad	Nota Note Note Nota Anm.	Descrizione	Description	Dé signation	Beschreibung	Descrìpziò n
3	031.42.034.00.52	1		Cerchio ruota posteriore	Rear wheel rim	Janta roue AR.	Hinterradfelge	Llanta ruoda trasera
4	15.36000.000	1		Flap 17/18x25	Bead 17/18x25	Flap 17/18x25	Felgenband 17/18x25	Flap cinta tapa radios 17/18x25
5	13.27120.000	1		Dado speciale	Special nut	Ecrou spéciale	Spezialmutter	Tuerca especial
6	25.55812.000	1		Perno ruota posteriore	Rear wheel pin	Pivot roue arrière	Hinterradbolzen	Perno ruoda trasera
7	031.41.016.00.00	6		Vite TEF M6x14	Screw TEF M6x14	Vis TEF M6x14	Schraube TEF M6x14	Tornillo TEF M6x14
8	031.42.030.00.00	1		Disco freno posteriore	Rear brake disk	Disque frein arrière	Hinterbrems Scheibe	Disco freno trasero
9	031.42.002.00.00	2		Distanziale mozzo post. Dx	RH rear hub spacer	Entretoise moyeu arrière D.	Distanz li	Distanciadór buje tras. Der.
10	10.66000.000	2		Paraolio 35x47x7	Oil seal 35x47x7	Pare-huile 35x47x7	Dichtring 35x47x7	Sello de lub. 35x47x7
11	020.42.004.00.00	2		Cuscinetto 25x47x12	Bearing 25x47x12	Roulement 25x47x12	Lager 25x47x12	Cojinete 25x47x12
12	031.42.005.00.00	1		Distanziale interno	Inner spacer	Entretoise interne	Inneres Distanzstück	Distanciadór interior
13	031.42.037.00.52	36		Raggio	Spoke	Bras	Speiche	Radio
14	13.17123.000	6		Dado TECF M8	Nut TECF M8	Ecrou TECF M8	Mutter TECF M8	Tuerca TECF M8
15	031.42.038.00.00	1		Corona Z48	Ring gear Z48	Couronne Z48	Zahnkranz Z48	Corona Z48
16	31.96827.000	6		Vite speciale M8X26	Special screw M8X26	Vis spéciale M8X26	Spezialschraube M8X26	Tornillo especial M8X26
17	13.17120.000	1		Dado M8 flangiato	Nut M8	Ecrou M8	Mutter M8	Tuerca M8
18	036.42.009.00.00	1		Fermacopertone	Tire fastener	Caoutchouc serrure chambre	Reifen Halter	Agarre cubierta ant.
19	031.42.003.00.00	1		Catena P114	Chain P114	Chaîne P114	Kette P114	Cadena P114
20	031.42.008.00.00	1		Maglia congiunzione 5/8x1/4	Connecting link 5/8x1/4	Maillon jonction 5/8x1/4	Kettenschloss 5/8x1/4	Enganche cadena 5/8x1/4
21	031.42.014.80.00	1		Mozzo posteriore c/cuscinetti	Rear hub with ballbearing	Moyeu arrière avec roulements	Hinterrad Nabe	Buje del. c/cojinetes
22	026.42.008.00.52	1		Ruota posteriore completa	Rear wheel	Roue AR.	Hinterrad	Rueda trasera
23	031.42.051.00.00	36		Nipple	Nipple	Ecrou	Nippel	Tuerca
24	C01.26.001.00.00	1		Seeger 47x1,75	Circlip 47x1,75	Circlip 47x1,75	Seeger 47x1,75	Seeger 47x1,75

Tav.43

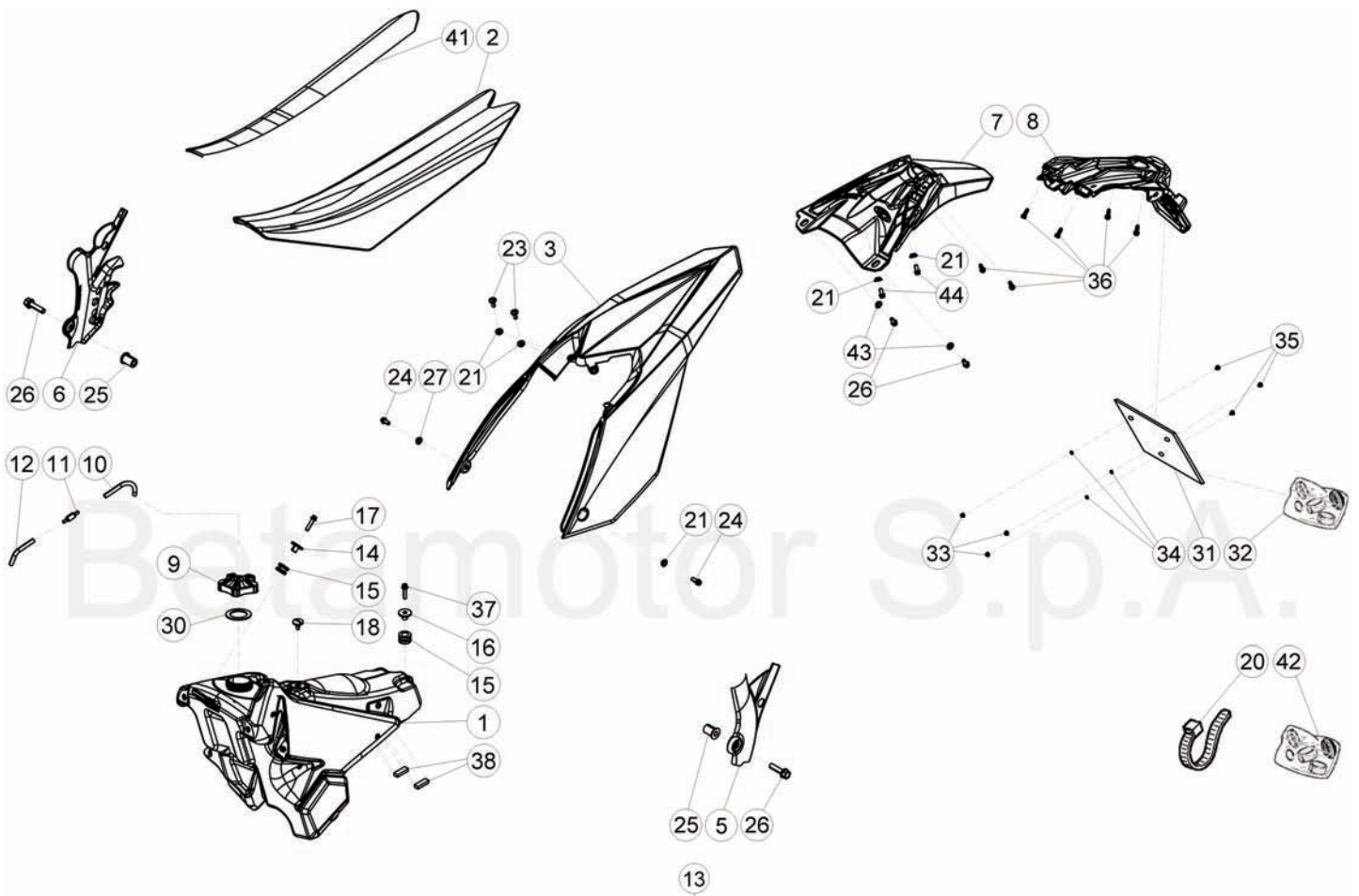

© Copyright 2017 Betamotor S.p.A.

Tav.43

Pos Loc Pos Ps Pos	Numero Number Numé ro Número Nummer	Q.tà Q.ty Q.té M.ge C.ad	Nota Note Note Nota Anm.	Descrizione	Description	Dé signation	Beschreibung	Descrìpziò n
1	031.43.074.10.51	1		Serbatoio	Fuel tank	Réervoir carburant	Kraftstofftank	Deposito gasolina
2	031.43.065.00.00	1		Sella	Seat	Siege	Sattel	Sillin
3	031.43.030.10.51	1		Parafango posteriore	Rear mudguard	Garde-boue AR.	Hinterradkotflügel	Guardabarros tras.
5	020.43.060.10.59	1		Protezione telaio Sx	L.H. frame guard	Protection chassis G.	Rahmenschutz Links	Protección bastidor izquierda
6	020.43.061.10.59	1		Protezione telaio Dx	R.H. frame guard	Protection chassis D.	Rahmenschutz Rechts	Protección bastidor derecha
7	036.43.006.37.59	1		Portatarga	Plate holder	Porte-plaque	Kennzeichenträger	Porta matr.
8	020.43.034.10.59	1		Portatarga	Plate holder	Porte-plaque	Kennzeichenträger	Porta matr.
9	031.43.118.00.00	1		Tappo serbatoio completo	Filler cap	Bouchon de réervoir	Tankverschluss	Tapón depósito
10	020.43.003.00.00	1		Tubo tappo-valvola sfiato	Plug-bleeder valve pipe	Tuyau bouchon-soupape reniflard	Leitung Verschluss- Entlüftungsventil	Tubo tapón-valvula purga de aire
11	021.43.018.00.00	1		Valvola sfiato serbatoio	Reservoir breather valve	Soupape reniflard réervoir	Ventil Behälterentlüftung	Valvula alivio depósito
12	020.43.004.00.00	1		Tubo valvola sfiato serbatoio	Reservoir breather valve pipe	Tuyau soupape reniflard réervoir	Leitung Ventil Behälterentlüftung	Tubo valvula alivio depósito
13	031.43.138.82.00	1		Decalco	Decalcs kit	Decalco	Satz Kleber	Kit adhesivos
14	020.43.002.00.00	1		Distanziale serbatoio benzina ant.	Fuel tank front spacer	Entretoise avant réervoir	Distanzstück vorne Benzintank	Distanciador delantero depósito
15	28.91946.000	2		Silentbloc	Silentbloc	Silentbloc	Puffer	Silent-block
16	031.43.002.00.00	1		Distanziale	Spacer	Entretoise	Distanzstück	Distanciador
17	11.50010.000	1		Bullone M6x25	Bolt M6x25	Boulon M6x25	Bolzen M6x25	Tornillo M6x25
18	31.89010.000	1		Vite spec. bloccaggio sella	Seat locking screw	Vis blocage selle	Schraube	Tornillo bloqueo sillin
20	15.14264.000	1		Fascetta	Clamp	Collier	Schelle	Abrazadera
21	13.54820.000	6		Distanziale 6,5x9,0x13,5	Spacer 6,5x9,0x13,5	Entretoise 6,5x9,0x13,5	Distanzstück 6,5x9,0x13,5	Distanciador 6,5x9,0x13,5
23	31.95510.000	2		Vite TBCE M6x12	Screw TBCE M6x12	Vis TBCE M6x12	Schraube TBCE M6x12	Tornillo TBCE M6x12
24	11.48025.000	5		Bullone 6x16 ch 8 rs	Bolt 6x16 ch 8 rs	Boulon 6x16 ch 8 rs	Bolzen 6x16 ch 8 rs	Tornillo 6x16 ch 8 rs
25	27.33740.000	2		Rivetto filettato M6	Threaded rivet M6	Rivet fileté M6	Niete mit gewinde M6	Remache roscado M6
26	11.49070.000	2		Bullone 6x20 ch rs	Bolt 6x20 ch rs	Boulon 6x20 ch rs	Bolzen 6x20 ch rs	Tornillo 6x20 ch rs
27	13.62000.000	1		Distanziale	Spacer	Entretoise	Distanzstück	Distanciador
30	031.43.116.00.00	1		Guarnizione tappo	Packing for cap	Joint bouchon	Deckeldichtung	Junta tapón
31	018.43.010.10.59	1		Portatarga	Plate holder	Porte-plaque	Kennzeichenträger	Porta matr.
32	031.43.103.82.00	1		Kit catadiottri	Reflectors kit	Jeu catadioptrés	Kit Rückstrahlern	Juego catafaros
33	13.11010.000	3		Dado autobloccante M5	Self locking nut M5	Ecrou de sécurité M5	Mutter, selbstsichernd M5	Tuerca de seguridad M5
34	27.36000.000	3		Rondella 5x11	Washer 5x11	Rondelle 5x11	U.Scheibe 5x11	Arandela 5x11
35	31.29860.000	3		Vite M5x16 TTLIC	Screw M5x16 TTLIC	Vis M5x16 TTLIC	Schraube M5x16 TTLIC	Tornillo M5x16 TTLIC
36	31.79960.000	6		Vite autofilettante M6x15	Self tapping screw M6x15	Vis taraud M6x15	Schraube, Blech M6x15	Tornillo autorosc. M6x15
37	11.50300.000	1		Bullone 6x30 ch rs	Bolt 6x30 ch rs	Boulon 6x30 ch rs	Bolzen 6x30 ch rs	Tornillo 6x30 ch rs
38	031.43.004.00.00	2		Tampone serbatoio	Tank buffer	Silentbloc réervoir	Puffer tank	Silent-block deposito
41	031.43.025.00.00	1		Copertura sella	Saddle cover	Hous. de selle	Abdeckung	Cubierta sill.
42	031.43.136.82.00	1		Kit targhette RR-S MY17	K. name plates RR-S MY17	Jeu monogr. RR-S MY17	Satz Plaketten. RR-S MY17	Letreros RR-S MY17
43	13.62000.000	2		Distanziale	Spacer	Entretoise	Distanzstück	Distanciador
44	11.48025.000	2		Bullone 6x16	Bolt 6x16	Boulon 6x16	Bolzen 6x16	Tornillo 6x16

Tav.43A

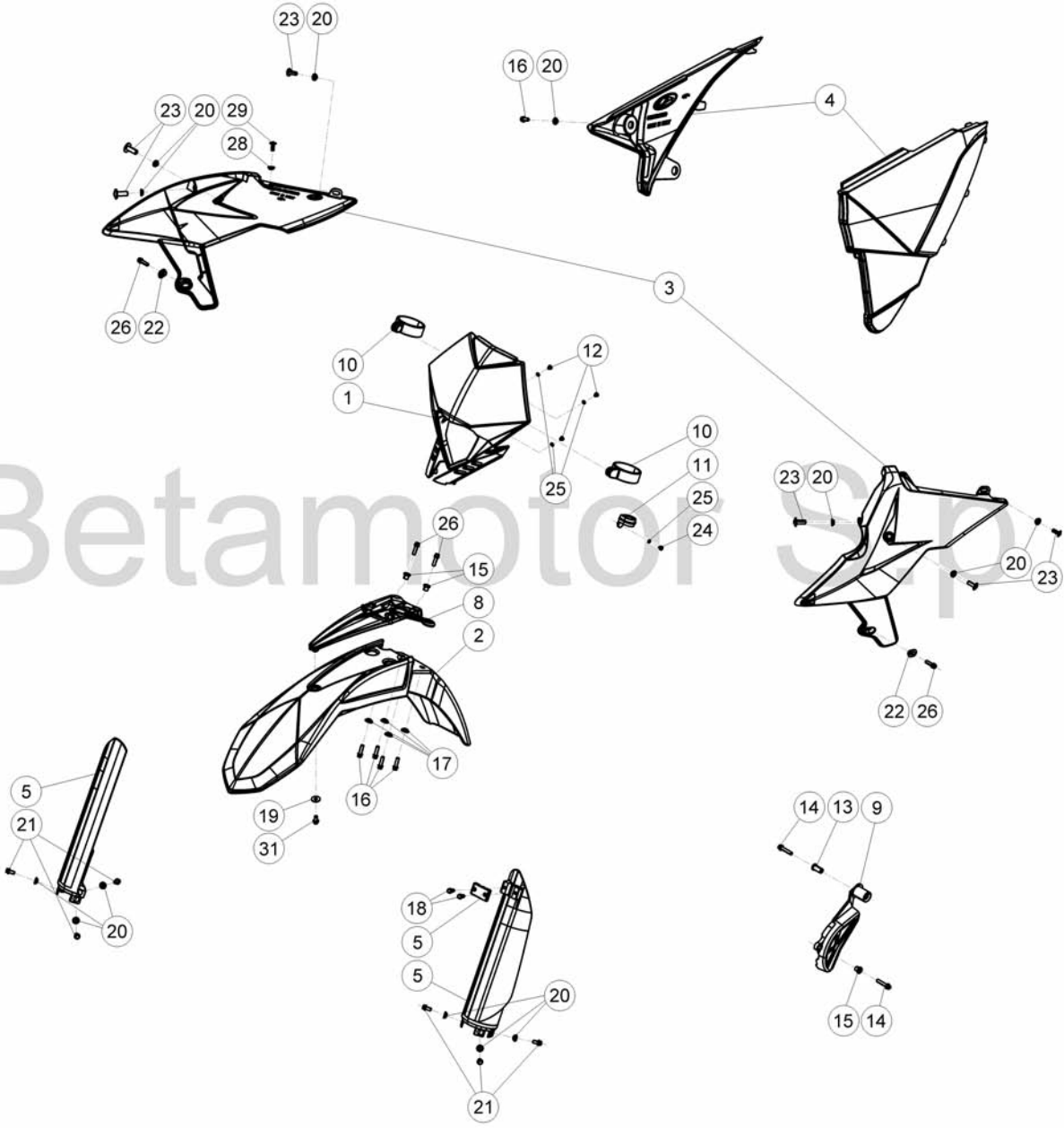

© Copyright 2017 Betamotor S.p.A.



Tav.43A

Pos Loc Ps Pos	Numero Number Numéro Nummer	Q.tà Q.ty Q.té M.ge C.ad	Nota Note Note Nota Anm.	Descrizione	Description	Dé signation	Beschreibung	Descrìpziò n
1	020.43.015.00.51	1		Mascherina	Mask	Masque	Maske	Má scara
2	031.43.034.10.51	1		Parafango anteriore	Front mudguard	Garde-boue avant	Vorderer Kotflügel	Guardabarros delantero
3	031.43.140.00.51	1		Fianchetti serbatoio	Tank panels	Panneaux laterales	Benzintankseiten	Flancos
4	026.43.021.00.51	1		Coppia fianchetti scatola filtro	Airbox panels, pair	Couple cotes laterales boî tier filtre à air	Luftfiltergehä useseiten	Flancos caja filtro aire
5	016.43.001.82.51	1		Kit protezioni stelo	Fork tube protections kit	Jeu protections tube fourche	Kit Abdeckungen Gabelschlauch	Juego protecció nes tubo horquilla
7	25.91330.159	1		Ponticello tubo freno	Brake pipe sprocket	Etrier tube frein	Bügel Bremsschlauch	Abrazadera tubo freno
8	020.43.141.10.59	1		Supporto parafango	Fender stay	Appui aile	Kotflügelstuetze	Soporte de guardabarros
9	020.43.062.10.59	1		Coperchio pignone	Sprocket cover	Couvercle pignon	Deckel Ritzel	Tapa piñ ó n
10	14.40081.000	2		Elastico fissaggio mascherina	Headlight holder elastic rubber	Elastique de fixation cache phare	Befestigungsband Lichtschildchen	Elastico
11	25.24464.000	1		Passacavo	Grommet	Passe-câ ble	Kabeldurchgang	Pasacables
12	31.26190.000	3		Vite M4x12 TCIC	Screw M4x12 TCIC	Vis M4x12 TCIC	Schraube M4x12 TCIC	Tornillo M4x12 TCIC
13	13.49189.000	1		Distanziale	Spacer	Entretoise	Distanzstü ck	Distanciator
14	11.50300.000	2		Bullone 6x30 ch rs	Bolt 6x30 ch rs	Boulon 6x30 ch rs	Bolzen 6x30 ch rs	Tornillo 6x30 ch rs
15	13.49190.000	3		Distanziale 10mm	Spacer 10mm	Entretoise 10mm	Distanzstü ck 10mm	Distanciator 10mm
16	11.48025.000	5		Bullone 6x16 ch 8 rs	Bolt 6x16 ch 8 rs	Boulon 6x16 ch 8 rs	Bolzen 6x16 ch 8 rs	Tornillo 6x16 ch 8 rs
17	13.54841.000	4		Distanziale	Spacer	Entretoise	Distanzstü ck	Distanciator
18	31.79960.000	2		Vite autofilettante M6x15	Self tapping screw M6x15	Vis taraud M6x15	Schraube, Blech M6x15	Tornillo autorrosc. M6x15
19	27.74786.000	1		Rondella	Washer	Rondelle	U.Scheibe	Arandela
20	13.54820.000	13		Distanziale 6,5x9,0x13,5	Spacer 6,5x9,0x13,5	Entretoise 6,5x9,0x13,5	Distanzstü ck 6,5x9,0x13,5	Distanciator 6,5x9,0x13,5
21	11.47015.000	6		Bullone M6x10	Bolt M6x10	Boulon M6x10	Bolzen M6x10	Tornillo M6x10
22	020.43.012.00.00	2		Distanziale	Spacer	Entretoise	Distanzstü ck	Distanciator
23	31.95510.000	6		Vite TBCE M6x12	Screw TBCE M6x12	Vis TBCE M6x12	Schraube TBCE M6x12	Tornillo TBCE M6x12
24	31.23360.000	1		Vite autofilettante 4x10	Self tapping screw 4x10	Vis taraud 4x10	Schraube, Blech 4x10	Tornillo autorrosc. 4x10
25	27.34650.000	4		Rondella	Washer	Rondelle	U.Scheibe	Arandela
26	11.49070.000	4		Bullone 6x20 ch rs	Bolt 6x20 ch rs	Boulon 6x20 ch rs	Bolzen 6x20 ch rs	Tornillo 6x20 ch rs
28	13.62000.000	1		Distanziale	Spacer	Entretoise	Distanzstü ck	Distanciator
29	31.30035.000	1		Bullone M6x25 TBCEI	Bolt M6x25 TBCEI	Boulon M6x25 TBCEI	Bolzen M6x25 TBCEI	Tornillo M6x25 TBCEI
31	11.46501.000	1		Bullone M6x10	Bolt M6x10	Boulon M6x10	Bolzen M6x10	Tornillo M6x10

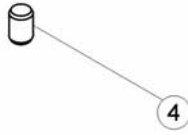

Betamotor S.p.A.

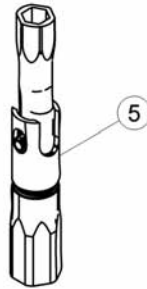
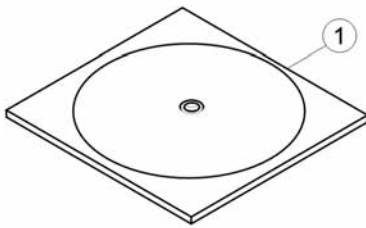

© Copyright 2016 Betamotor S.p.A.

Pos Loc Pos Ps Pos	Numero Number Numéro Número Nummer	Q.tà Q.ty Q.té M.ge C.ad	Nota Note Note Nota Anm.	Descrizione	Description	Dé signation	Beschreibung	Descrìpiò n
1	031.44.043.00.00	1		CD Manuale uso e manutenzione	Owner' s manual CD	CD Manuel d' utilisation et entretien	CD Bedienungs und Wartungshandbuch	CD Manual de Uso y Manutención
2	020.44.202.80.00	1		Borsa attrezzi	Tool roll	Trousse à outils	Werkzeugtasche	Bolsa herramientas
3	020.44.003.00.00	1		Chiave a brugola 6mm	Allen wrench 6mm	Clé Allen 6mm	Sechskantschlüssel 6mm	Llave de imbus 6mm
4	020.44.004.00.00	1		Bussola 8	Bush 8	Joint 8	Buchse 8	Buje 8
5	020.44.010.00.00	1		Chiave candela	Ignition wrench	Clé à bougie	Zündkerzenschlüssel	Llave buja
6	031.44.016.82.00	1		Strumento diagnostica	Check instrument	Instrument de diagnostic	Diagnose-Instrument	Instrumento de diagnosis



Handwriting practice area consisting of 20 horizontal dotted lines.



