

4

45

MY 2018-2019

4-STROKE
350cc - 500cc



WORKSHOP MANUAL



Beta
motorcycles



TABLE OF CONTENTS

PREAMBLE	2
TECHNICAL FEATURES OF ENGINE	4
SPECIAL EQUIPMENT	5
1 REMOVING THE ENGINE FROM THE VEHICLE	6
2 ENGINE DISASSEMBLY	17
2.1 THERMAL UNIT	17
2.1.1 CYLINDER HEAD: DISASSEMBLING HYDRAULIC TENSIONER	19
2.1.2 CYLINDER HEAD: DISASSEMBLING THE CAMSHAFT SUPPORT, FIXED PAD AND SPARK PLUG SEAT O-RING	20
2.1.3 CYLINDER HEAD: REMOVING CAMSHAFTS	21
2.1.4 CYLINDER HEAD: UNCOUPLING FROM CYLINDER	22
2.1.5 DISASSEMBLING CYLINDER AND PISTON	24
2.2 DISASSEMBLY OF IGNITION UNIT, TIMING CHAIN AND PADS	25
2.2.1 STATOR AND FLYWHEEL	25
2.2.2 TIMING CHAIN AND PADS	28
2.2.3 PICK-UP	30
2.3 PINION AND SPACER	30
2.4 CLUTCH UNIT AND COOLANT PUMP COVER	31
2.5 ENGINE LUBRICATION CIRCUIT	35
2.5.1 OIL PUMPS CONTROL GEARS	36
2.5.2 HIGH-PRESSURE OIL PUMP	36
2.5.3 LOW-PRESSURE OIL PUMP AND BY-PASS VALVE	37
2.5.4 OIL PRESSURE CONTROL VALVE	38
2.5.5 PAPER OIL FILTER	38
2.6 COUNTERSHAFT	39
2.7 PRIMARY GEAR	40
2.8 ELECTRIC IGNITION	41

2.8.1 ELECTRIC KICKSTART UNIT	42
2.9 PEDAL KICKSTART - OPTIONAL	43
2.10 EXTERNAL GEARSHIFT UNIT	45
2.11 CRANKSHAFT, GEARBOX UNIT AND INTERNAL GEARSHIFT	46
2.11.1 NUT ON LEFT SIDE OF CRANKSHAFT	46
2.11.2 OPENING THE CRANKCASE	47
2.11.3 CRANKSHAFT	49
2.11.4 INTERNAL GEARSHIFT UNIT AND COMPLETE GEARBOX	49
2.12 DISASSEMBLY OF PARTS FROM CRANKCASES	51
2.12.1 RIGHT CRANKCASE HALF	51
2.12.1.1 PISTON OIL JETS	51
2.12.1.2 EXTRACTION OF COUNTERSHAFT SUPPORT BEARING	52
2.12.2 LEFT CRANKCASE HALF	52
2.12.2.1 INNER OIL FILTER	53
2.12.2.2 EXTRACTION OF DESMODROMIC DEVICE BEARING	53

3 ENGINE ASSEMBLY AND CHECKS	54
3.1 CRANKCASE HALF	55
3.1.1 EXTERNAL RIGHT SIDE	56
3.1.1.1 INSERTION OF OIL SEAL AND COUNTERSHAFT SUPPORT BEARING	58
3.1.2 INTERNAL RIGHT SIDE	59
3.1.3 EXTERNAL LEFT SIDE	60
3.1.4 INTERNAL LEFT SIDE	61
3.2 CHECKING THE CONNECTING ROD AND CRANKSHAFT	62
3.3 COMPLETE CRANKSHAFT ASSEMBLY	64
3.4 GEARBOX UNIT: CHECKS AND REASSEMBLY	65
3.4.1 GEARBOX UNIT CHECK	65
3.4.2 PRIMARY UNIT ASSEMBLY	66
3.4.3 SECONDARY UNIT ASSEMBLY	67
3.4.4 CHECKING THE FORKS, FORK PINS AND DESMODROMIC DEVICE	68
3.5 GEARBOX AND INTERNAL GEARSHIFT ASSEMBLY	70
3.6 CLOSING THE ENGINE CRANKCASE	73
3.7 BLOCKING THE CRANKSHAFT AT THE TOP DEAD CENTRE AND TIGHTENING THE NUT ON THE LEFT SIDE OF THE CRANKSHAFT	74
3.8 EXTERNAL GEARSHIFT	75
3.8.1 CHECKING THE COMPLETE DRIVE SHAFT	75
3.8.2 EXTERNAL GEARSHIFT ASSEMBLY	77
3.9 KICKSTARTER DEVICE (OPTIONAL)	77
3.9.1 CHECKING THE KICKSTART SHAFT UNIT AND ASSEMBLY	77
3.9.2 ASSEMBLY OF KICKSTARTER DEVICE	79
3.10 ELECTRICAL STARTER UNIT AND PRIMARY GEAR	80
3.10.1 CHECKING ELECTRICAL STARTER DEVICE ELEMENTS	80
3.10.2 COUPLING IGNITION AND PRIMARY GEARS TO THE MOTOR	81



TABLE OF CONTENTS

3.11 OIL PUMPS: INSPECTION AND REASSEMBLY 83	
3.11.1 INTAKE PUMP ASSEMBLY..... 85	
3.11.2 HIGH-PRESSURE PUMP AND CONTROL GEAR ASSEMBLY 86	
3.11.3 CHECKING AND ASSEMBLING THE PRESSURE CONTROL VALVE..... 87	
3.11.4 CHECKING AND ASSEMBLING THE OIL PUMP CONTROL GEARS..... 88	
3.11.5 PAPER OIL FILTER INSERTION 89	
3.11.6 CHECKING AND COUPLING THE COUNTERSHAFT..... 90	
3.12 CLUTCH UNIT..... 92	
3.12.1 CHECKING THE CLUTCH CASE, ROLLER BEARING AND INTERNAL CENTRE BEARING. 92	
3.12.2 CHECKING THE CLUTCH DISCS..... 93	
3.12.3 CHECKING THE SPRINGS..... 94	
3.12.4 CLUTCH DRUM AND CAP CHECK..... 94	
3.12.5 CHECKING THE THRUST BEARING DEVICE 95	
3.12.6 CLUTCH UNIT ASSEMBLY..... 95	
3.13 COOLANT PUMP 99	
3.13.1 CHECKING PUMP UNIT AND DISASSEMBLY 99	
3.13.2 PUMP UNIT ASSEMBLY..... 100	
3.14 ASSEMBLY OF COMPLETE CLUTCH COVER..... 101	
3.15 CHECKING AND COUPLING OF TIMING CHAIN, FIXED AND MOBILE PADS 103	
3.16 IGNITION SYSTEM..... 103	
3.16.1 IGNITION SYSTEM CHECK 104	
..... 104	
3.16.2 COUPLING OF IGNITION SYSTEM TO CRANKCASE..... 104	
3.17 THERMAL UNIT 107	
3.17.1 CHECKING THE PISTON, PIN BOLT AND PISTON RINGS..... 107	
3.17.2 CYLINDER CHECK 109	
3.17.2.1 COUPLING PLAY..... 109	
3.17.3 CYLINDER HEAD: DISASSEMBLING AND CHECKING AUXILIARY DEVICES..... 110	
3.17.3.1 LUBRICATION JETS AND CENTRING PINS. 110	
3.17.3.2 ROCKER ARM/SHAFTS UNIT 111	
3.17.3.3 CALIBRATED DISCS FOR VALVE PLAY ADJUSTMENT..... 112	
3.17.4 CYLINDER HEAD: DISASSEMBLING AND CHECKING VALVE UNITS..... 113	
3.17.4.1 SPRINGS 114	
3.17.4.2 VALVE GUIDES, VALVES AND SEATS..... 114	
3.17.4.3 OIL-SCRAPER RINGS AND LOWER CUP 116	
3.17.5 CYLINDER HEAD: CHECKING THE CYLINDER HEAD BODY..... 116	
3.17.6 CHECKING THE CAMSHAFTS..... 117	
3.17.7 CHECKING THE CAMSHAFT SUPPORT 118	
3.17.8 CYLINDER HEAD: INSERTION OF LOWER CUP AND OIL-SCRAPER RING 119	
3.17.9 CYLINDER HEAD: ASSEMBLY OF VALVE UNIT..... 120	
3.17.10 CYLINDER HEAD: REPOSITIONING CALIBRATED DISCS. ASSEMBLING ROCKER ARM PINS AND ROCKER ARMS AND COUPLING THE SPARK PLUG 121	
3.17.11 CYLINDER HEAD: INSERTION OF OIL JETS, CENTRING PINS AND SPARK PLUG O-RING..... 122	
3.17.12 PISTON: APPLICATION OF THE OIL-SCRAPER AND SEAL BANDS, APPLICATION OF THE SEEGER..... 123	
3.17.12.1 PISTON: APPLICATION OF THE OIL-SCRAPER AND SEAL BANDS, VERSION 350CC-390CC..... 123	
3.17.12.2 PISTON: APPLICATION OF THE OIL-SCRAPER AND SEAL BANDS..... 124	
3.17.12.3 PISTON: SEEGER APPLICATION 125	
3.17.13 APPLICATION OF PISTON TO CYLINDER..... 125	
3.17.14 APPLICATION OF PISTON-CYLINDER COUPLING TO CRANKCASE..... 127	
3.17.15 COUPLING HEAD TO CYLINDER..... 129	
3.17.16 COUPLING CAMSHAFTS TO CYLINDER HEAD AND PHASING..... 130	
3.17.17 VALVE PLAY..... 133	
3.17.18 CHECKING AND COUPLING OF MECHANICAL TENSIONER TO ENGINE..... 135	
3.17.19 COUPLING CYLINDER HEAD COVER GASKETS AND CYLINDER HEAD COVER 137	
3.18 PINION COUPLING 138	
3.19 RELEASING THE CRANKSHAFT 138	
3.20 COUPLING OIL CAPS..... 139	
3.21 COUPLING GEARSHIFT LEVER 140	
4 REASSEMBLY OF ENGINE IN THE VEHICLE 141	
TABLE OF ENGINE COMPONENTS FASTENING TORQUES 156	
TABLE OF FRAME/MOTOR FASTENING TORQUES 156	
TABLE OF SUPERSTRUCTURE FASTENING TORQUE VALUES 156	
RECOMMENDED ENGINE MAINTENANCE 157	
RECOMMENDED LUBRICANTS AND LIQUIDS 158	

PREAMBLE

This publication is intended for workshops specialised on repair of motorbikes and motorcycles. Use, where prescribed, special Betamotor tools.

Use Betamotor spare parts only. For their codes refer to the spare parts manual for the specific vehicle or version.

The warranty and liability on vehicle safety lapses when maintenance or repair:

- Are **NOT** performed by workshops specialised on repair of motorbikes and motorcycles.
- Are **NOT** carried out carefully following the requirements contained in the technical documentation;
- Are **NOT** carried out using special Betamotor tools, where required;
- Are **NOT** carried out using Betamotor official spare parts.

Read this entire manual with care before operating the engine. Sufficient knowledge of the components that make up the engine and of all the procedures to be followed for inspection and maintenance contribute to lengthen the life of the engine.

The paragraphs have been enhanced with schematic illustrations highlighting each subject in order to make reading immediately understandable.

Informative note

Betamotor S.p.A. is engaged in a policy of ongoing improvement of its products. This is why it could be possible to note slight differences between the contents of this document and the vehicle upon which you are carrying out repairs and/ or maintenance. Betamotor S.p.A. models are exported to numerous countries in which there are different standards concerning Highway Codes and procedures for approval of the vehicle. Relying on your understanding, Betamotor S.p.A. therefore deems it necessary to reserve the right to modify its products and technical documentation at any time without prior warning.

We respect and defend the environment

All that we do has an impact on the whole Planet and its resources. Betamotor S.p.A., wishing to safeguard the interests of the entire Community, would like to make customers and technical operators aware of ways of using the vehicle and of disposal of its parts in total compliance with standards in force in terms of environmental pollution, waste disposal and recycling.

SAFETY

Carbon monoxide

- Exhaust gases contain carbon which is poisonous. Carbon monoxide can cause loss of conscience and lead to death. When starting the engine, make sure the place you are in is well-ventilated. Never start the engine in a closed place.
- Starting the engine in closed places can be done only if provided with relevant gas discharge evacuation devices.

Petrol

- Petrol is extremely flammable and can be explosive in some conditions.
- Keep heat sources, sparks and flames away from the work area.
- Always work in a well-ventilated area.
- Never use petrol as a solvent for cleaning. Do not handle it unless absolutely necessary.
- Never use petrol to clean components by means of compressed air.
- Keep out of the reach of children.

Engine oil

- Motor oil can cause skin illnesses if carried often and for prolonged periods in contact with skin.
- If you touch motor oil, clean parts with soap and water as soon as possible.
- In case of contact with the eyes, rinse them abundantly with water and seek medical advice.
- If swallowed, do not induce vomiting in order to avoid breathing the product into the lungs; seek immediate medical advice. If you believe the product has been breathed into the lungs, bring the concerned person urgently to the hospital.
- Used oil contains dangerous substances which are harmful for the environment. When changing it, you must be equipped to dispose of it in compliance with existing law.
- Avoid dispersing used oils in the environment.
- Keep out of the reach of children.



Coolant liquid

- In some situations, the ethylene glycol contained in the coolant is flammable and its flame is invisible. Should ethylene glycol catch fire, though its flame is invisible, it can cause burns.
- Do not bring the coolant in contact with hot parts. These parts could be hot enough to cause the liquid to ignite.
- The coolant (ethylene glycol) can irritate skin and is poisonous if swallowed.
- Should the coolant come into contact with the skin, immediately remove contaminated clothing or footwear and wash with soap and water. In case of contact with the eyes, rinse them abundantly with clean water and seek medical advice immediately. Should it be swallowed, do not induce vomiting in order to avoid breathing the product into the lungs. Administer clean water and bring the concerned person immediately to the hospital, showing this product to the hospital staff.
- In the event of exposure to a high concentration of vapours, bring the concerned person to an uncontaminated atmosphere and seek medical advice if necessary.
- Do not remove the radiator cap when the engine is still hot. When coolant is pressurised, it can spurt out violently and cause burns.

- Coolant contains dangerous substances which are harmful for the environment. When changing it, you must be equipped to dispose of it in compliance with existing law.
- Do not disperse coolant into the environment.
- Keep out of the reach of children.

Hot parts

- The engine and the exhaust system get very hot and stay at that temperature for a long time, even after the engine has been turned off. Wait for them to cool down before handling these parts or intervening on areas around them. Use insulated gloves.

WARNINGS

The information contained in this paragraph is important so that the operations carried out on the engine can be performed without causing damage.

- Before disassembling, clean the motorcycle thoroughly.
- While you are disassembling it, clean all the parts and place them in containers exactly respecting the order of disassembly.
- Always use special tools wherever necessary and when thus prescribed.
- Always use glues, sealant and lubricants wherever prescribed. Respect the indications concerning their technical features.
- Always replace parts such as gaskets, O-rings and safety washers with newly supplied parts.
- When loosening or tightening nuts or screws, always start with the larger ones or from the centre. Always respect the indicated tightening torques.
- Use only Betamotor original spare parts.



TECHNICAL FEATURES OF ENGINE

Type	Single cylinder, 4-stroke, liquid-cooled with countershaft and electric starting			
Bore x stroke RR 350	88x57.4			
Bore x stroke RR 390	88x63.4			
Bore x stroke RR 430	95x60.8			
Bore x stroke RR 480	100x60.8			
Displacement [cm ³] RR 350	349.1			
Displacement [cm ³] RR 390	386			
Displacement [cm ³] RR 430	431			
Displacement [cm ³] RR 480	478			
Compression ratio RR 350-390-430-480	13.19:1	12.5:1	12.3:1	11.9:1
Valve gear	4 valves			
TRANSMISSION				
	RR 350	RR390	RR430	RR480
Primary transmission	28/76	28/76	31/72	31/72
1st gear ratio	12/31	12/31	12/31	12/31
2nd gear ratio	15/28	15/28	15/28	15/28
3rd gear ratio	19/28	19/28	19/28	19/28
4th gear ratio	20/24	20/24	20/24	20/24
5th gear ratio	27/27	27/27	27/27	27/27
6th gear ratio	28/24	28/24	28/24	28/24
SECONDARY TRANSMISSION		CHAIN		

SPECIAL EQUIPMENT

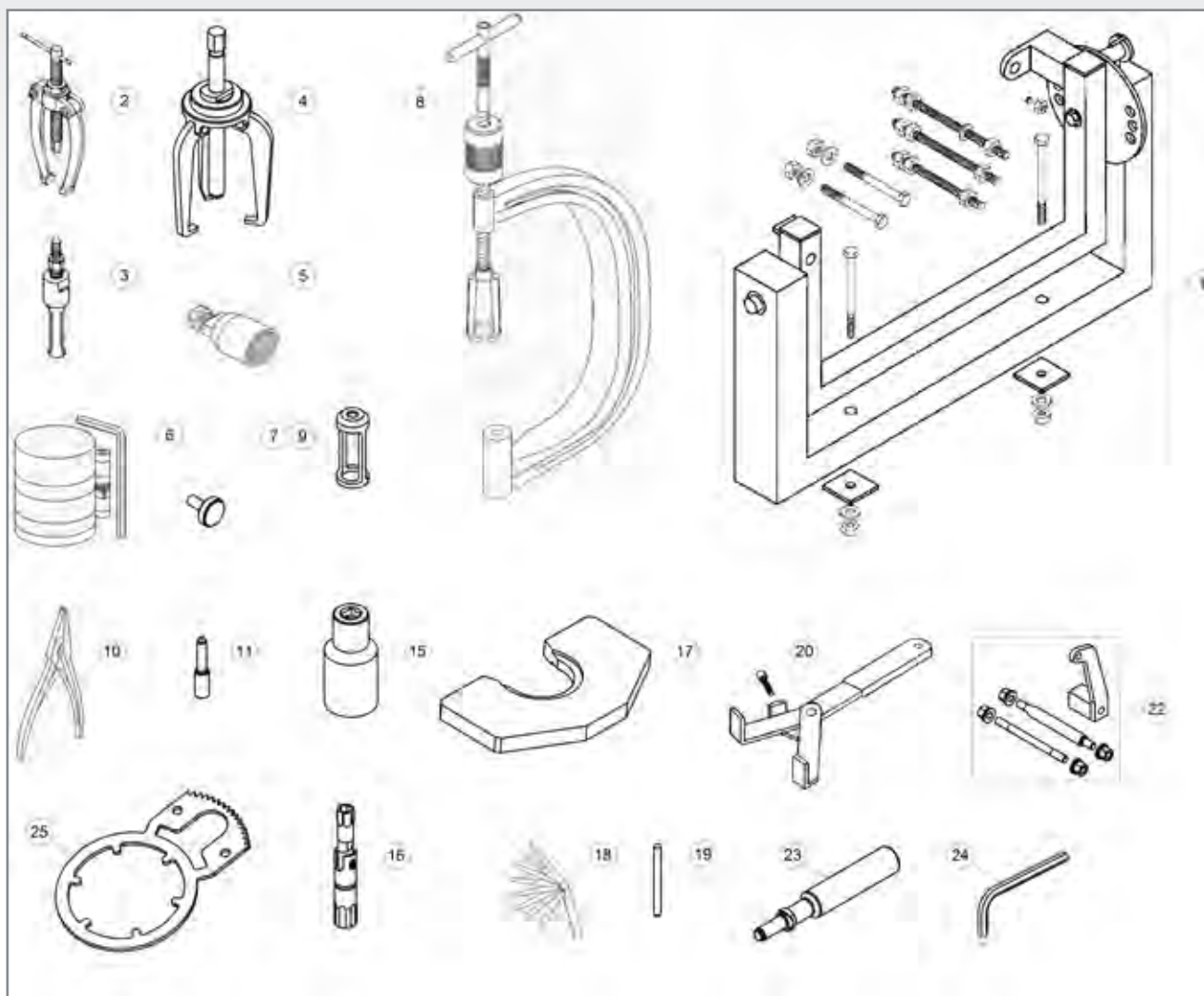

1. Engine assembly equipment code 36.25132.000;
2. Extractor code 36.25081.000;
3. Internal 20-30 mm bearing extractor code 006.14.016.00.00;
4. Extractor for gears code 006.14.015.00.00;
5. Flywheel extractor code 36.25173.000;
6. Set of piston rings code 006.14.017.00.00;
7. Chain-tensioner release tool code 006.14.005.00.00;
8. Valve assemb./disassemb. tool code 01.00043.000;
9. Valve spring assembly tool code 006.14.003.00.00;
10. Special ring pliers code 36.25097.000;
11. Tool for blocking crankshaft at TDC code 006.14.011.0.000;
12. 36mm socket spanner code 006.14.002.00.00;
13. Spark plug spanner code 020.44.010.00.00;
14. Connecting rod disassembly tool code 029.14.007.50.00;
15. Valve play gauge code 006.14.021.00.00;
16. Valve guide differential gauge code 006.14.018.00.00;
17. Clutch hub fixing spanner code 006.14.004.00.00;
18. Engine fixing code 006.14.014.00.00;
19. Pin elastic ring tool code 022.14.020.00.00
20. Special wrench code 006.44.000.00.00
21. Special wrench code 029.14.002.50.00

Symbols

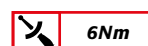

Value
Fastening torque



Loctite 243/
Sichel 100M



Silicone paste



Grease

1 REMOVING THE ENGINE FROM THE VEHICLE

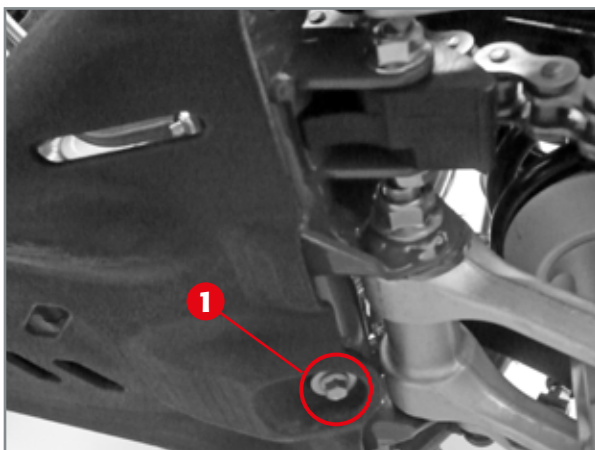

Rear engine guard fixing screw.

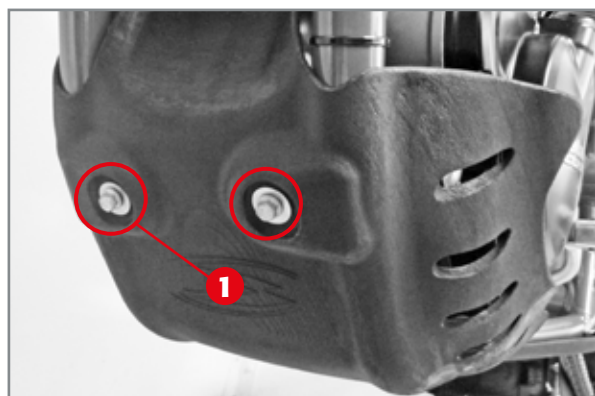

Front engine guard fixing screws.

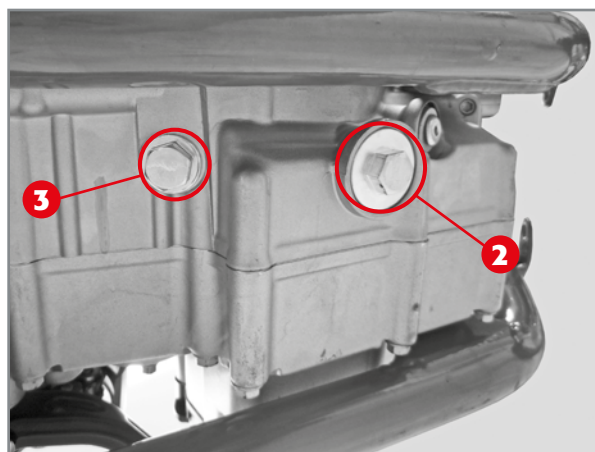

Screw 2 for draining motor oil and 3 for draining gear oil.

Carefully wash the vehicle

Before removing the engine from the vehicle, empty the following liquids:

- Motor oil;
- Gear/clutch unit oil;
- Coolant liquid.

In order to access the oil drain plug, remove the engine guard connected to the frame by means of the three screws 1.

Remove the screw 2 to empty the motor oil. Remove the screw 3 to empty the gear oil.

ATTENTION: Used oil contains dangerous substances which are harmful for the environment. When changing it, you must be equipped to dispose of it in compliance with existing law. Do not dispose of used oils in the environment.

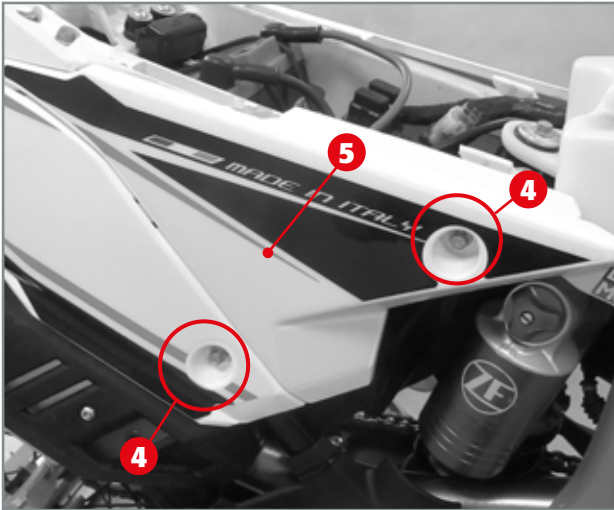

Remove the seat, the screws **4** and the side panel **5**.
This allows easy access to the silencer screw **6**.



Remove the exhaust pipe and the silencer.

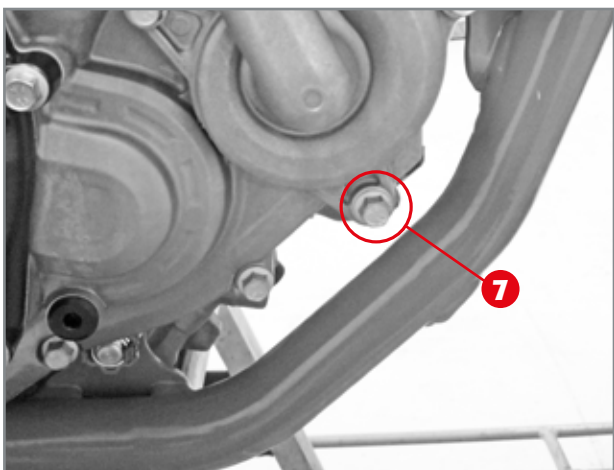

Drain the cooling system by means of the screw **7** and let the liquid outflow into a container (the cooling circuit contains 1.3l of liquid).

Remove the radiator cap.



Place the vehicle onto an adequate stand.

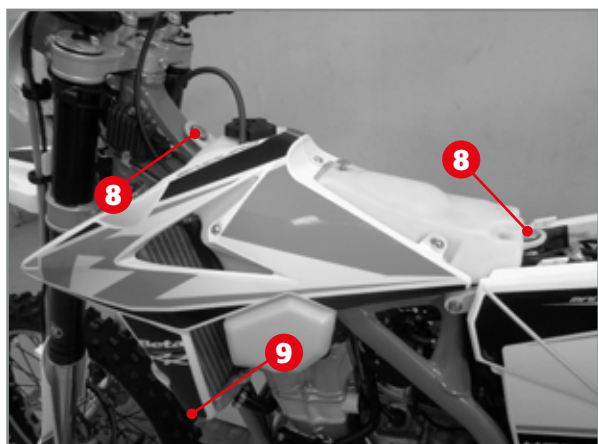

To dismantle the tank, remove the seat (if it has not been removed already), completely loosen the two screws **8** fixing the tank to the frame and screw **9** (one per side) which fixes the side to the radiator.

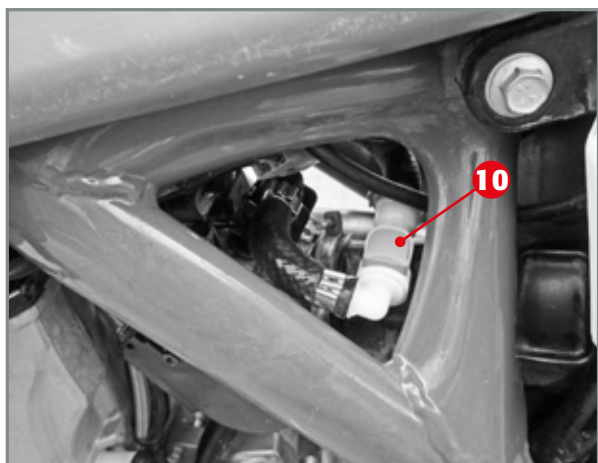

Disconnect the petrol pipe by pressing the relevant button of quick coupling **10**.

Lift the tank.

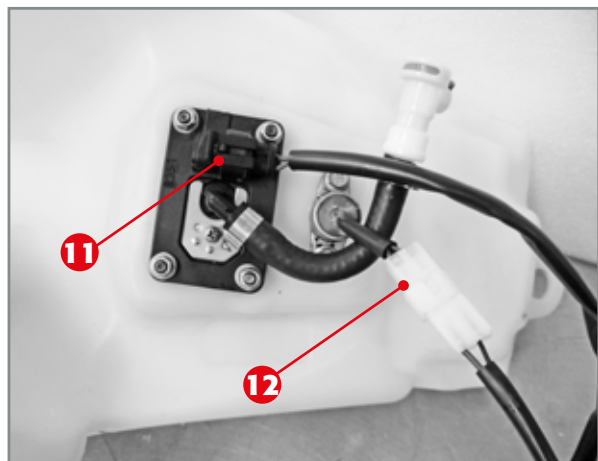

Disconnect the electric connectors **11** and **12**.

Remove the tank along with the sides.

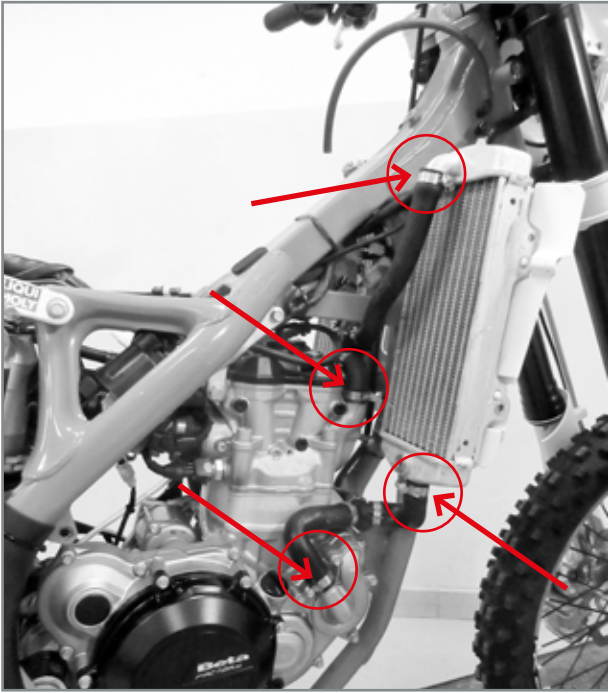

Disconnect the water hoses from the engine and from the right radiator.

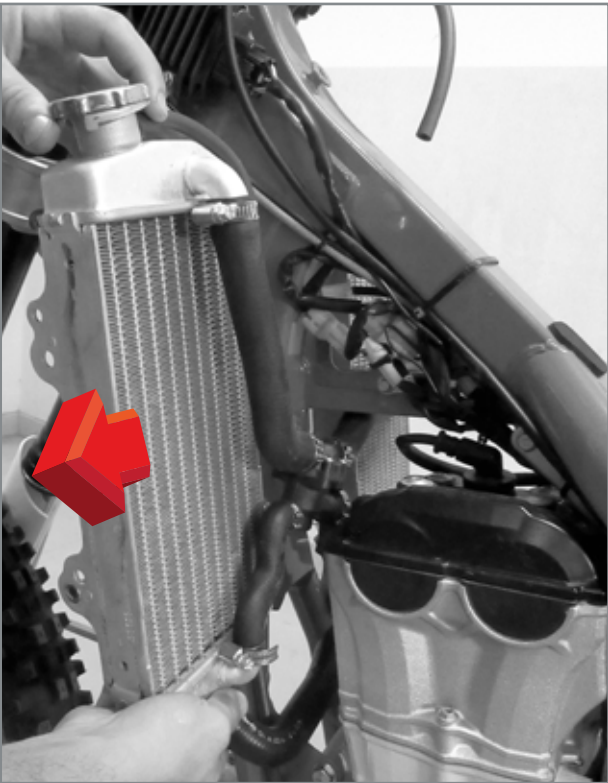

Remove the left radiator with pipes.



Disconnect the spark plug cap. Cut all straps binding the engine's electric system to the clutch pipe and to the frame.

Disconnect the engine ventilation pipes.



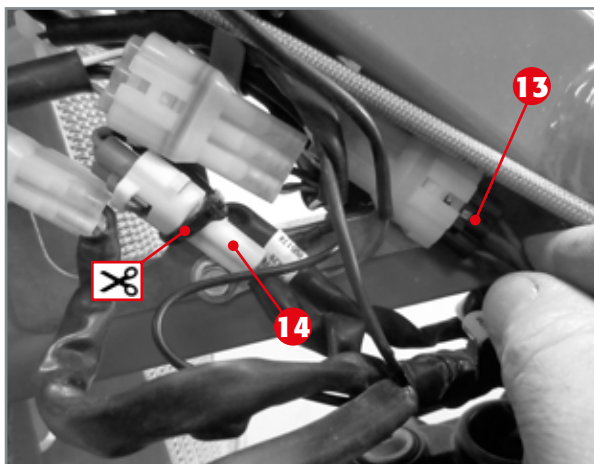

Release the connector **13** and cut the e clamp that fastens the connector **14** to its support.

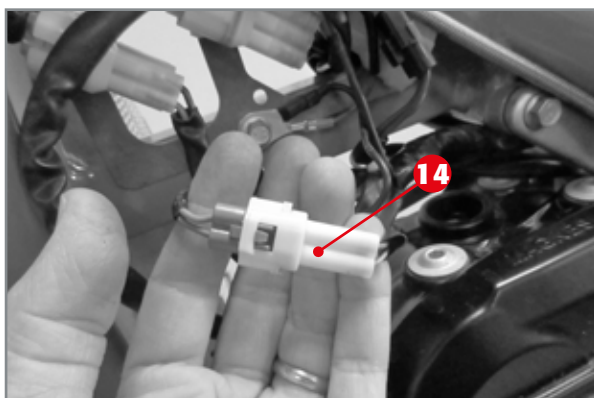

Disconnect the connector **14**.



Remove the start motor cable fixing nut.

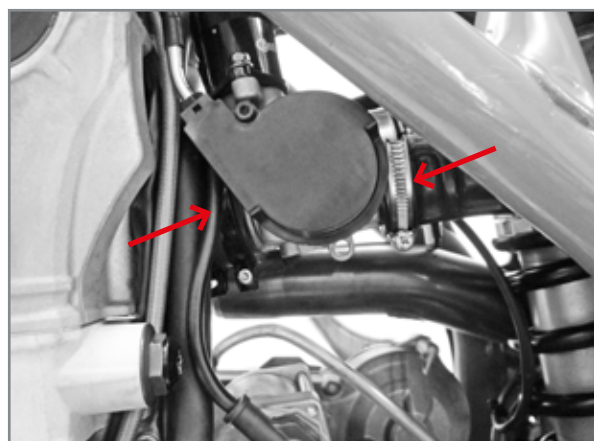

Loosen the throttle body straps from the air filter sleeve and from the manifold.

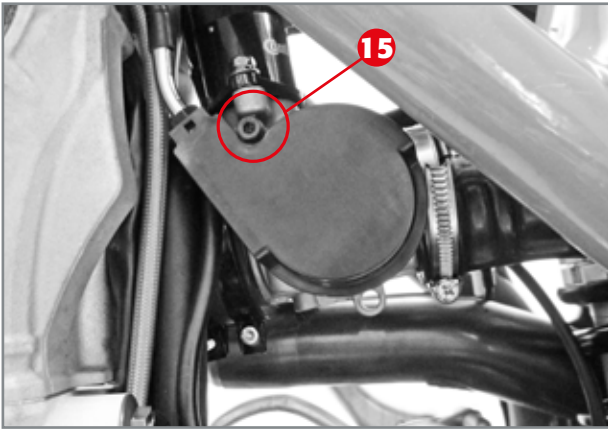

Remove the screw of the throttle body cover **15** and the cover itself.

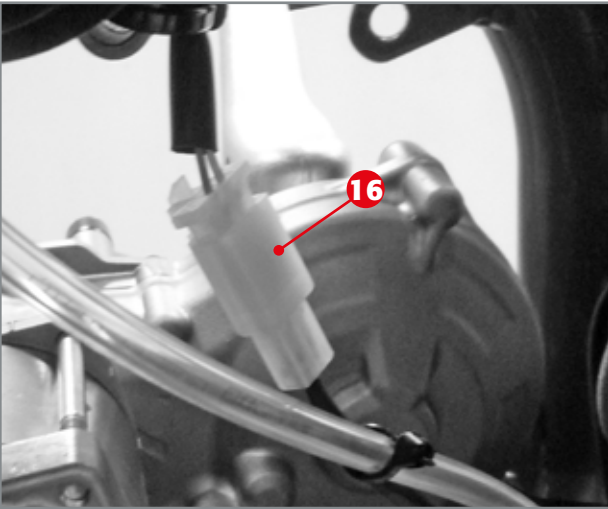

Disconnect the rear brake stop connector **16**.

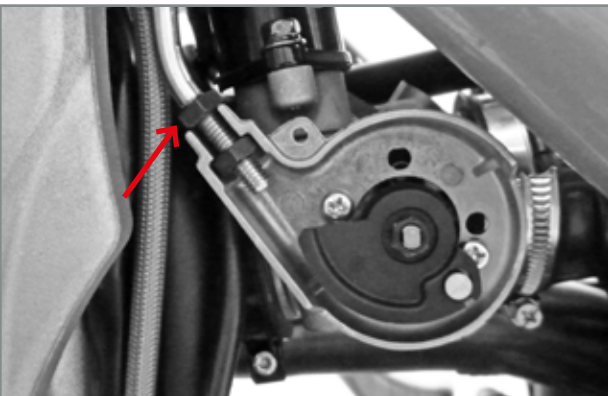

Loosen the adjustment nuts and release the gas cable.

Injection versions gas cables.

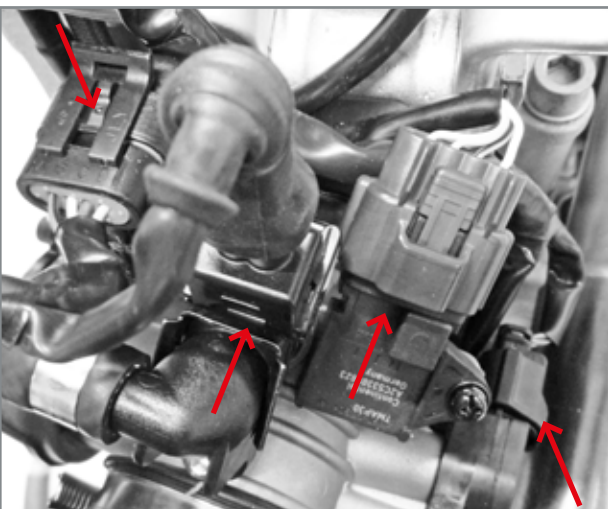

Disconnect the electric connectors indicated in the figure, relative to the throttle body.



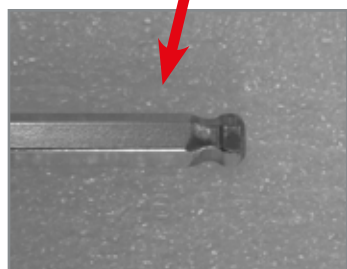
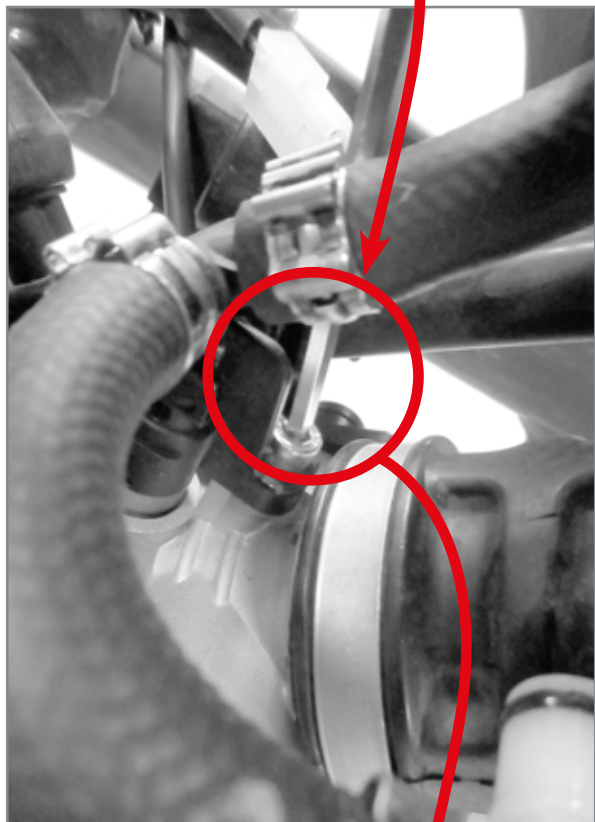
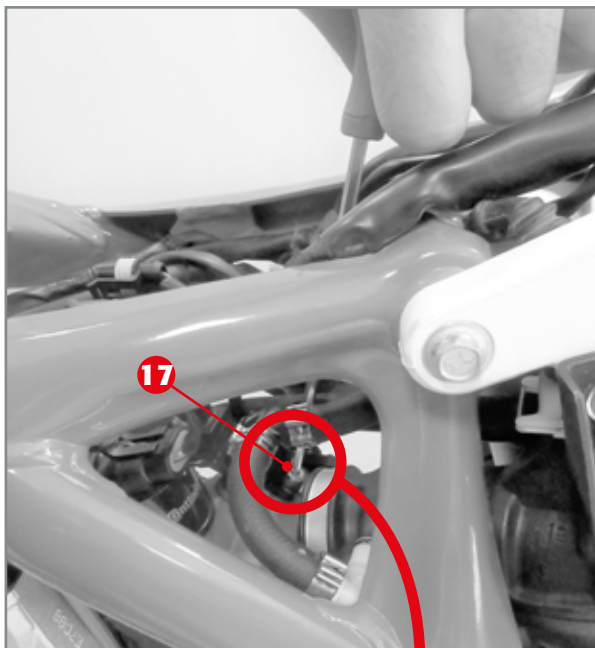

Remove the screw **17** fastening the injector to the throttle body, using a spanner as shown in the picture.

Remove the entire injector from the throttle body.

ATTENTION: Make sure no foreign objects get into the injector housing. We recommend plugging the housing with a clean cloth.

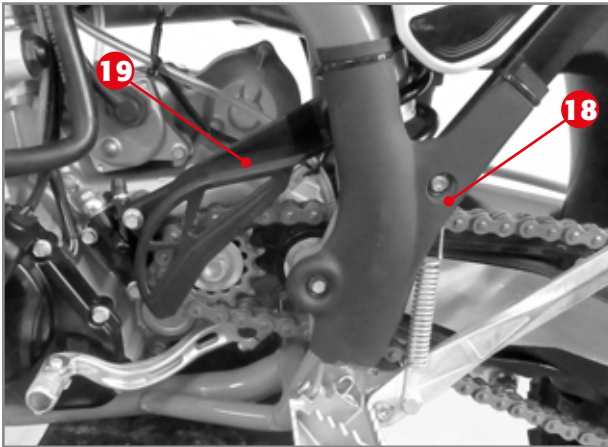

Remove the frame guards **18** (one each side) and the pinion guard **19**.

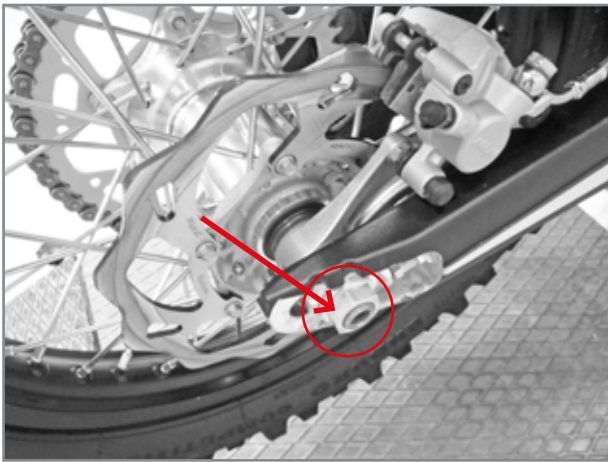

Remove the rear wheel nut.

Extract the pin enough to allow the wheel to advance towards the front of the vehicle.

Rotate the rear wheel lifting the chain in the pinion zone, so that the chain of the pinion itself is released.

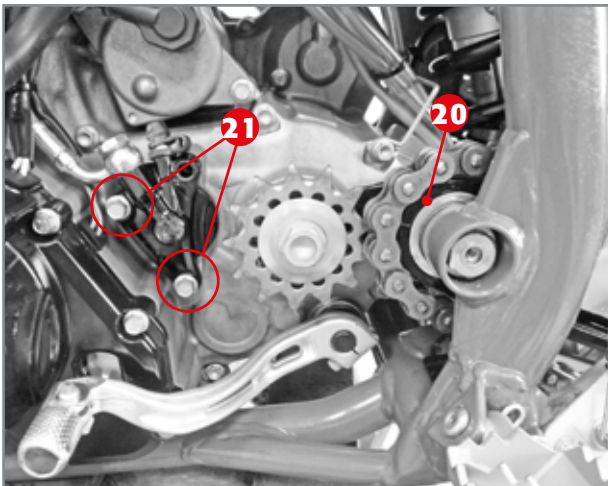

Rest the chain against the upper wedge **20**.

Remove the screws **21** fixing the clutch actuator to the crankcase half.

ATTENTION: Do not activate the clutch lever with the actuator uncoupled from the engine.



Remove the head connections.

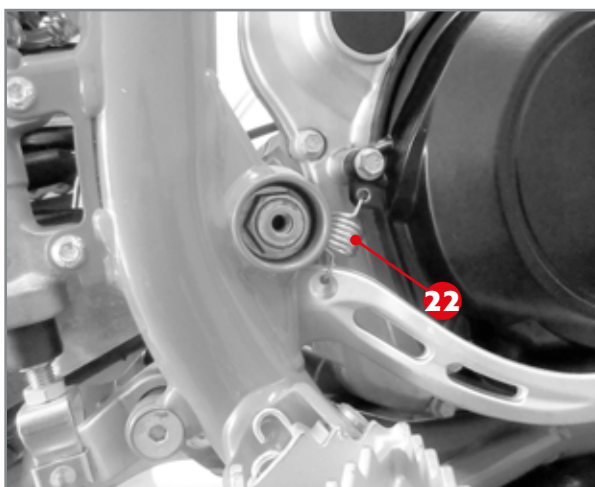

Release and remove the brake pedal return spring **22**.

Remove the kickstarter lever.

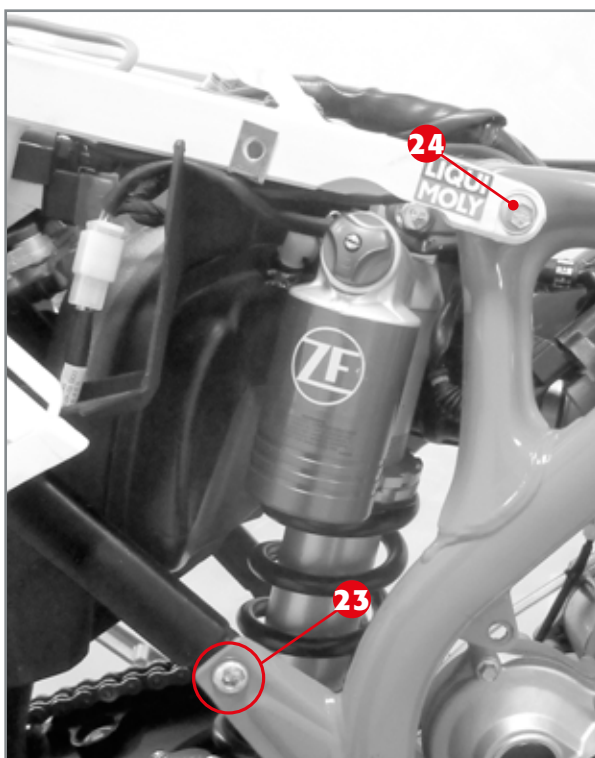

Remove the seat rail lower fixing screws **23** (one each side) and loosen the upper screws **24** (one each side).

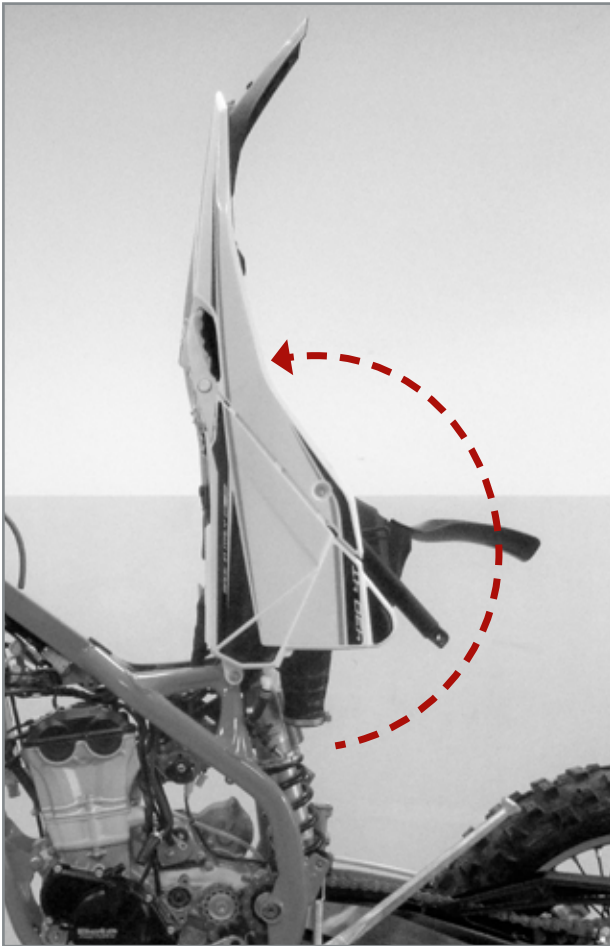

Rotate the entire filter box unit.

Remove the throttle body.

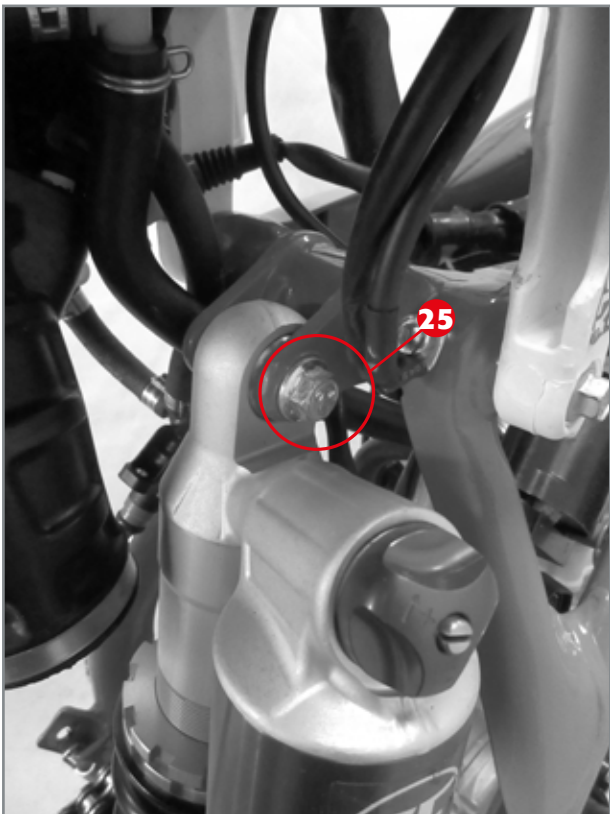

Remove the upper shock-absorber pin **25**.

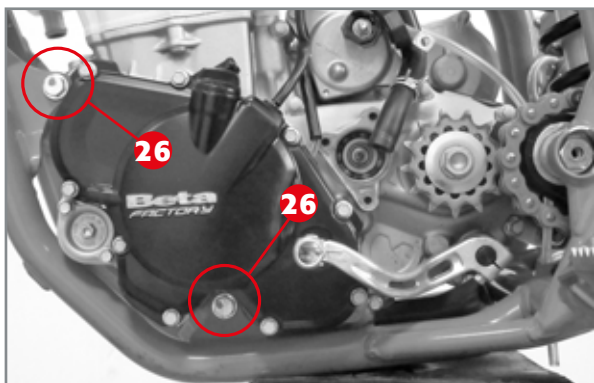

Loosen the engine pins **26**.

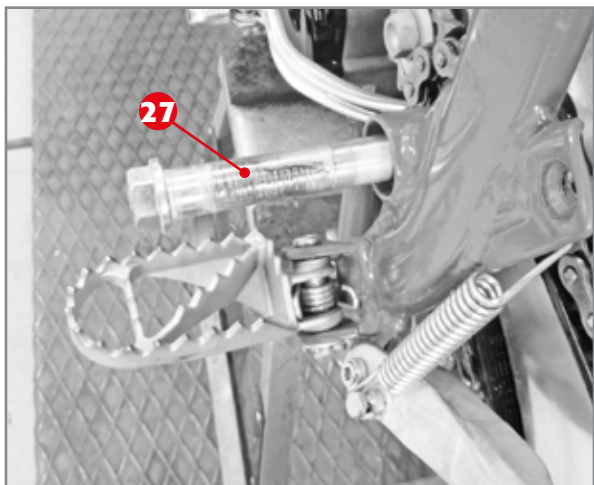

Remove the swingarm pin **27**.

Move the complete swing-arm unit towards the rear.

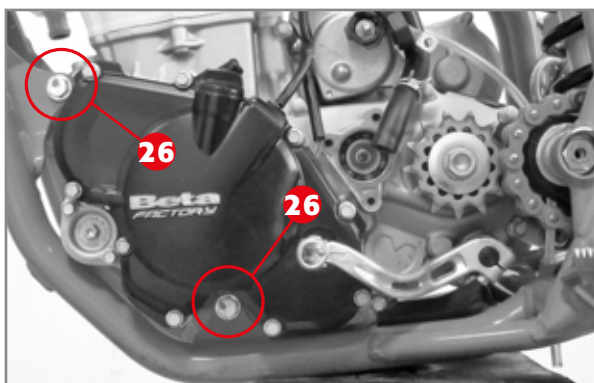

Remove the engine pins **26**.

Extract the engine from the frame and apply it to the specific stand code 3625132 000 using the specific front fixing bracket code 006140140 000.

2 ENGINE DISASSEMBLY

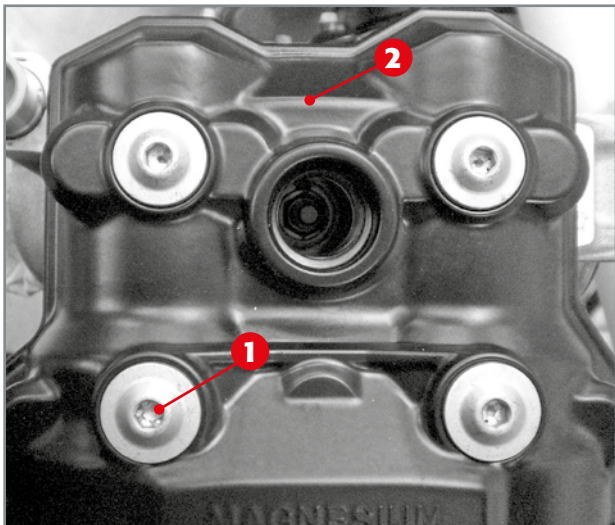

The four screws 1 of the cylinder head cover 2.

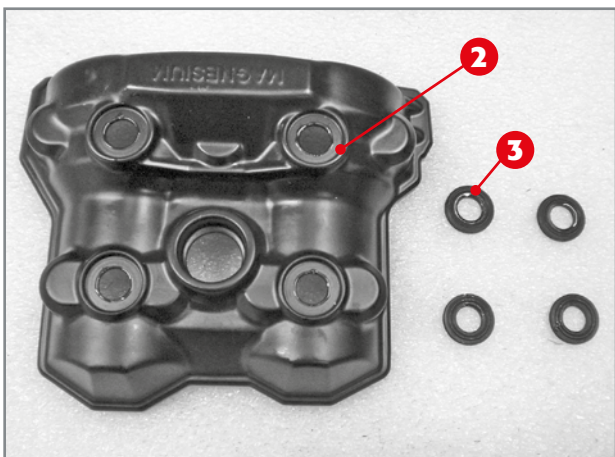

The cylinder head cover 2 and the four gaskets 3.

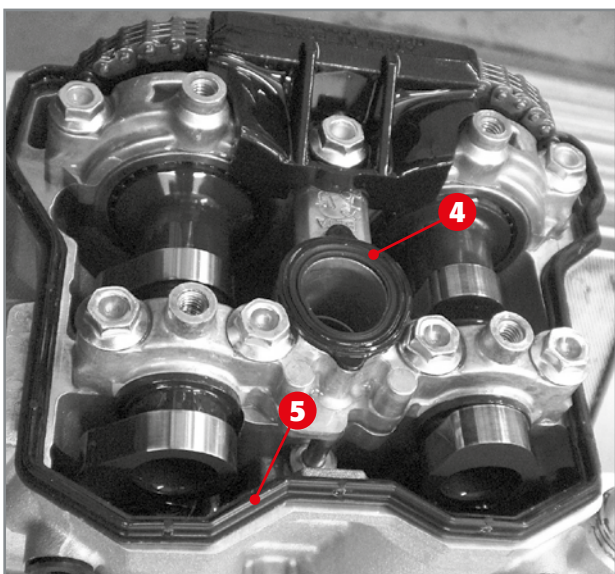

Spark plug gasket 4 and cylinder head cover gasket 5.

2.1 THERMAL UNIT

The thermal unit is made up of the head, cylinder and piston.

Before removing the cylinder head, bring the piston to the TDC and block the crankshaft: proceed as shown below.

Remove the 4 screws 1, the cylinder head cover 2 as well as the 4 screw gaskets 3.

Remove the spark plug gasket 4 and the cover gasket 5.

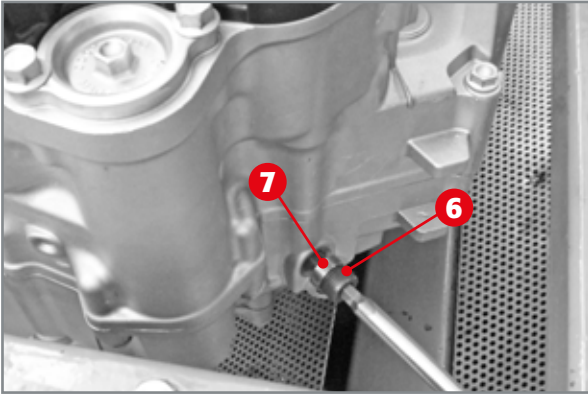

Crankshaft blocking screw 6 with copper washer 7.

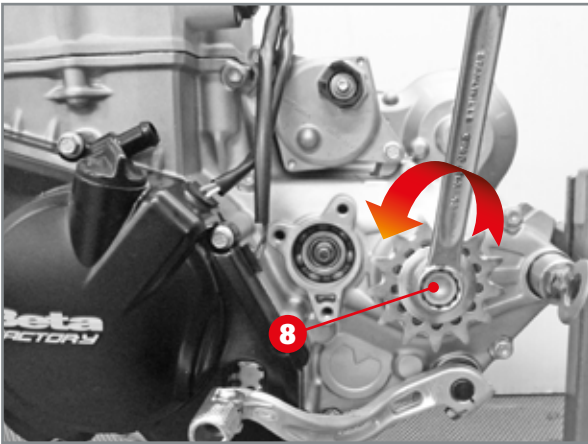

Rotation of transmission shaft.

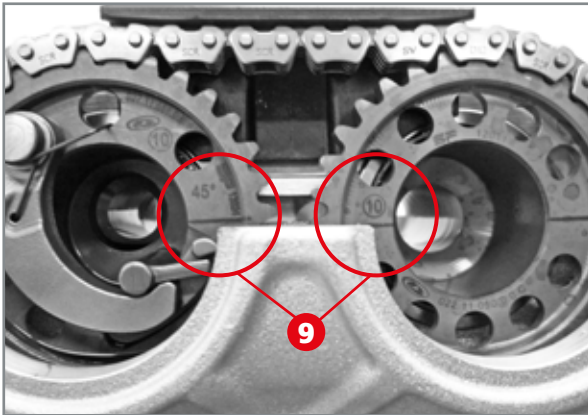

Alignment of camshafts.

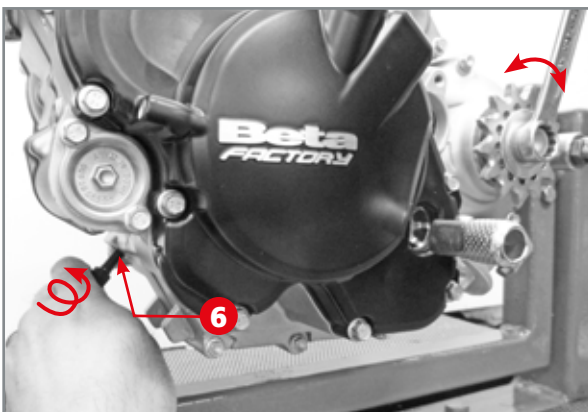

Blocking the crankshaft at TDC. Please note the locking screw 6 and the movement of the transmission shaft set with the open-end spanner.

Remove the crankshaft blocking screw **6**, remove the copper washer **7** and put the screw back into its seat without tightening it all the way. Alternatively, use the special engine locking tool (code 006140110000).

After having engaged the 6th gear, turn the transmission shaft **8** anti-clockwise - using an open-end spanner or similar - until the lines **9** on the toothed profiles of the camshafts are aligned.

Turn the transmission shaft in such position and, at the same time, turn the shaft blocking screw **6** by hand until it engages in the seat present on the crankshaft, preventing its rotation.

This way the crankshaft is blocked, by means of the screw **6**, at the Top Dead Centre (TDC) and now all the parts can be disassembled.

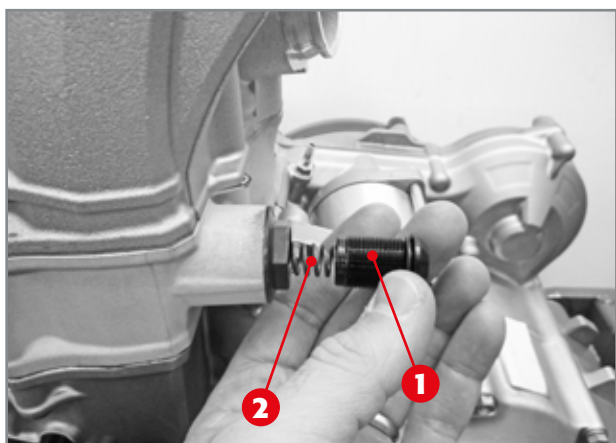

Cap and spring removal.

2.1.1 CYLINDER HEAD: DISASSEMBLING THE MECHANICAL TENSIONER

A chain which is not well-tensioned can cause:

- excessive vibrations for the chain which could make it jump teeth on the camshafts thus damaging the engine;
- incorrect and premature wear of the support bearings of the camshafts.

The engine is equipped with a mechanical tensioner in order to provide the chain with proper tensioning.

To remove it, proceed as follows:
remove the cap **1** and the spring **2**.

Fully unscrew the tensioner support **3** from the cylinder.

To remove the piston **4**, just push it out from the tensioner support **3**.

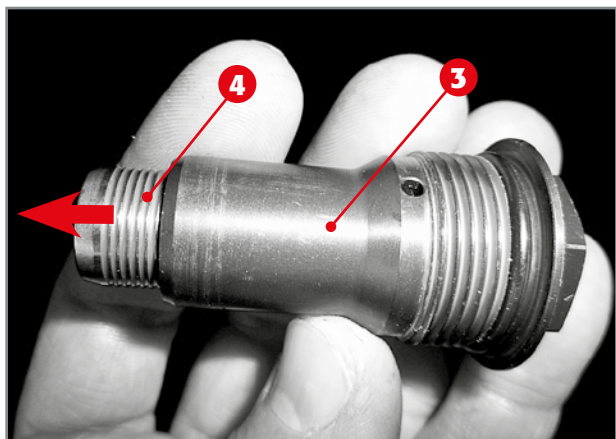

Tensioner support complete with piston.

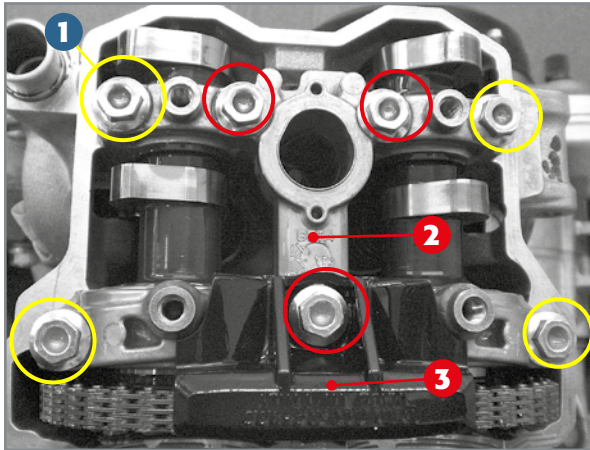

Fixing screws 1 camshaft support 2 and fixed pad 3. The four outer screws circled in blue must be removed first.

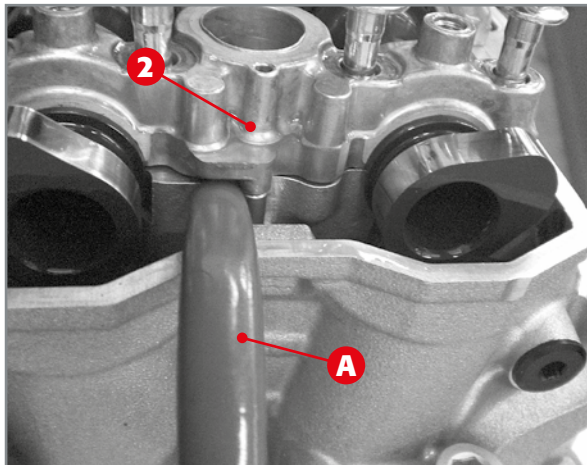

Uncoupling camshaft support 2 from cylinder head.

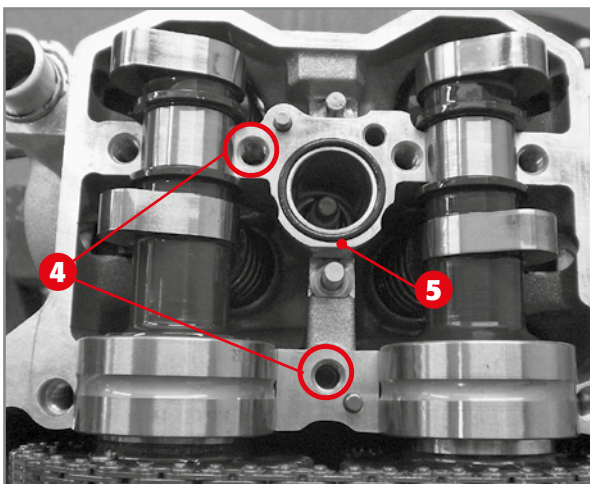

Two centring pins 4 and spark plug housing O-ring 5.

2.1.2 CYLINDER HEAD: DISASSEMBLING THE CAMSHAFT SUPPORT, FIXED PAD AND SPARK PLUG SEAT O-RING

To remove the camshafts, disassemble the camshaft support 2 and the fixed pad 3. Then loosen the seven screws 1 of the camshaft support, starting with the four outer ones (indicated in blue in the figure) and then the inner ones. Remove the fixed pad 3.

Attention: disassemble the camshafts only after having disassembled the hydraulic tensioner.

Using a plastic rod A or something similar, lever the head surface and the camshaft support 2 in order to lift it and remove it.

When uncoupling, pay attention to the two centring pins 4 located underneath the camshaft support. Remove the spark plug housing sealing O-ring 5 between the cylinder head and the camshaft support

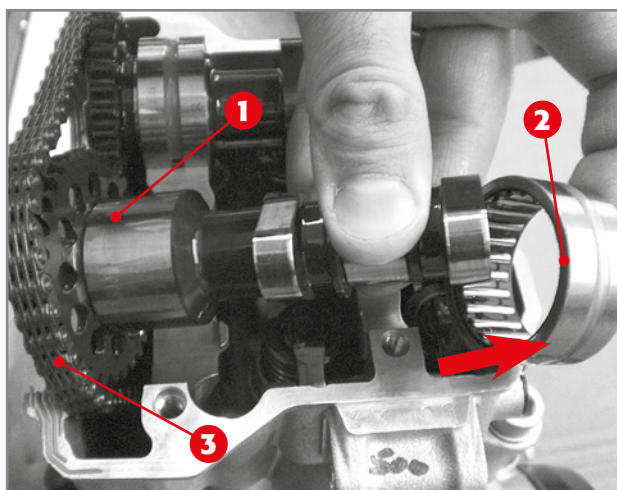

Removal of intake camshaft 1, bearing 2.

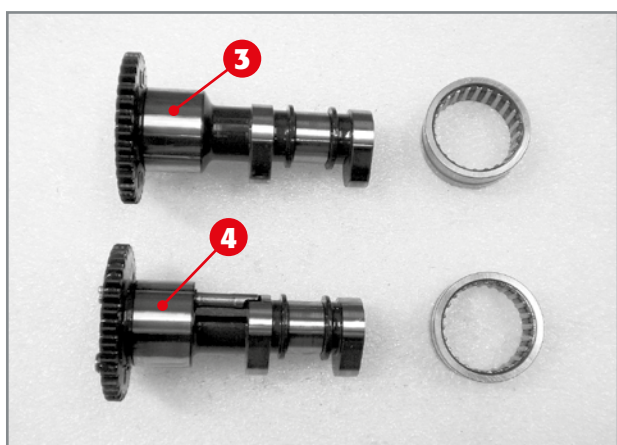

Camshafts (3 intake, 4 exhaust) with bearings.

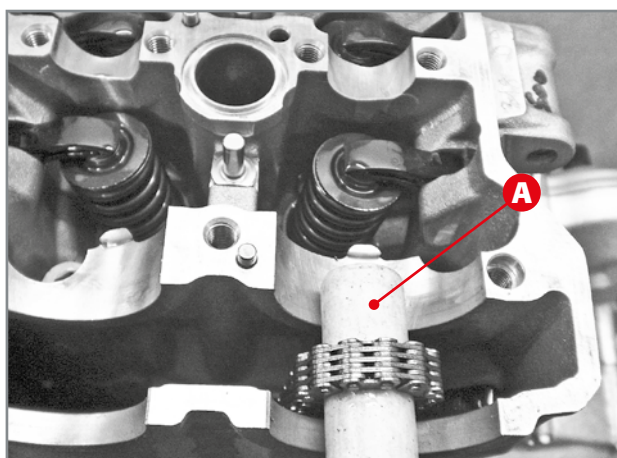

Plastic rod to support chain.

2.1.3 CYLINDER HEAD: REMOVING THE CAMSHAFTS

Lift the intake camshaft 1, pull out the bearing 2 and remove the chain 3 from the gear on the shaft.

Attention: the hydraulic tensioner must already have been removed in order to remove the camshafts.

In order to remove the exhaust camshaft 4, repeat the operations described for the removal of the intake camshaft.

ATTENTION: make sure the chain does not fall inside the dedicated compartment. For this purpose, it is recommended to interpose a plastic rod (or the likes) A between the chain and the head.

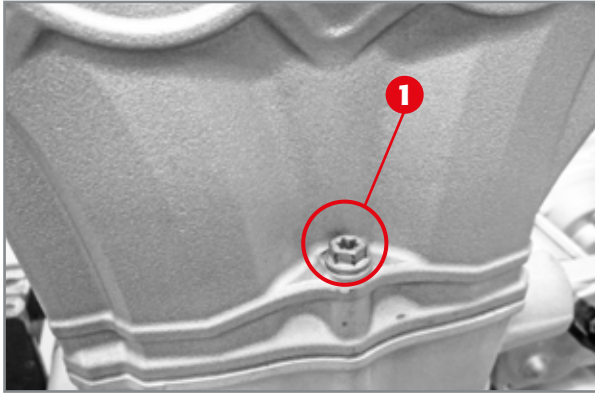

Chain-side head fixing screw.

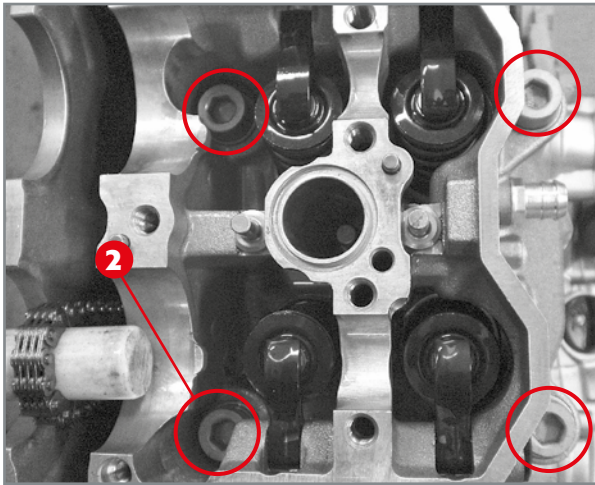

Head fixing screws 2.

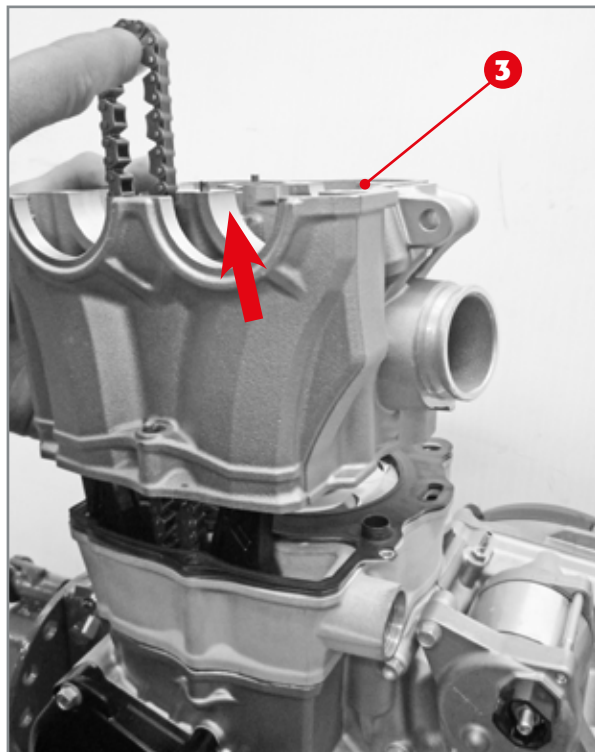

Head removal 3.

2.1.4 CYLINDER HEAD: UNCOUPLING FROM CYLINDER

Five screws fasten the head to the cylinder. Remove the cylinder head screw 1 on the outside of the chain-side cylinder head.

Remove the four cylinder head fixing screws 2, in a criss-cross pattern. Start with one of the two screws outside the cylinder head compartment. Then remove the respective washers.

Lift the cylinder head 3 with one hand and at the same time with the other hold the chain in tension thus preventing jams during disassembly. With the cylinder head lifted a few centimetres, drop the chain inside the compartment and pull out the head.

ATTENTION: should the chain fall inside, tension it before lifting the head.

ATTENTION: while lifting the head, pay attention to the centring bushes.

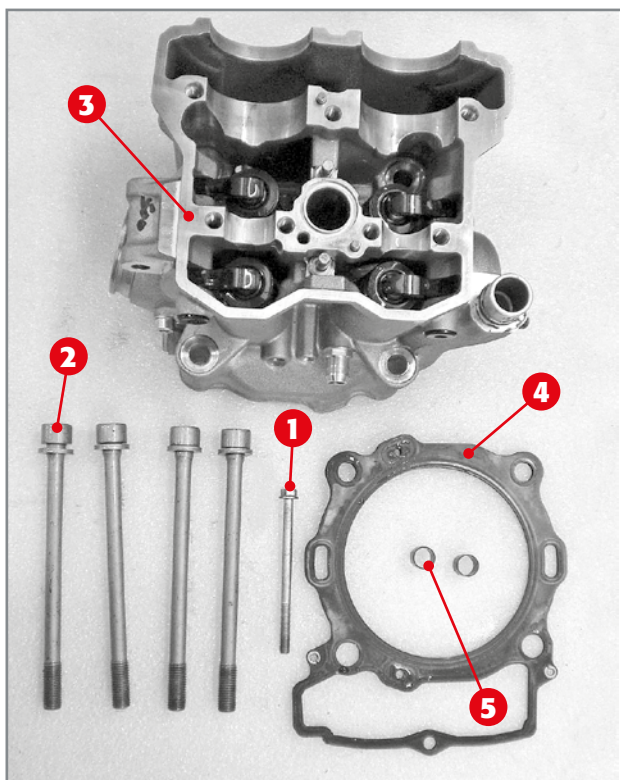

Remove the head gasket **4** and the two centring bushes **5**.

Cylinder head elements:

- 1) Screw M6x80;
- 2) Cylinder head screws M10x1.25;
- 3) Complete cylinder head;
- 4) Cylinder-head gasket;
- 5) Centring bushes.

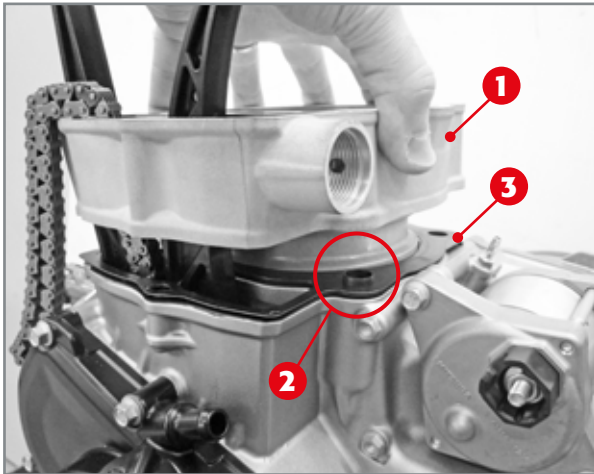

Cylinder removal.

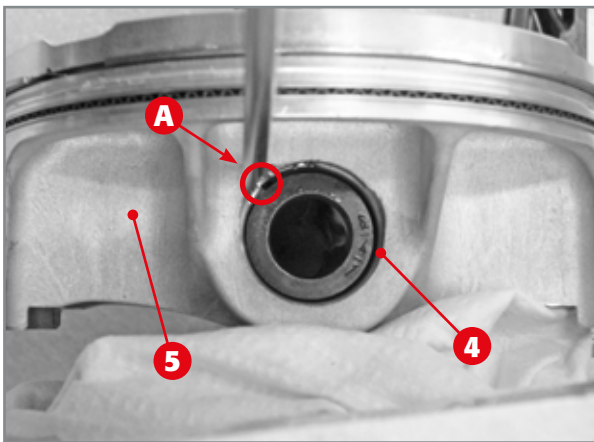

Removal of elastic ring 4 from right hand side of piston.

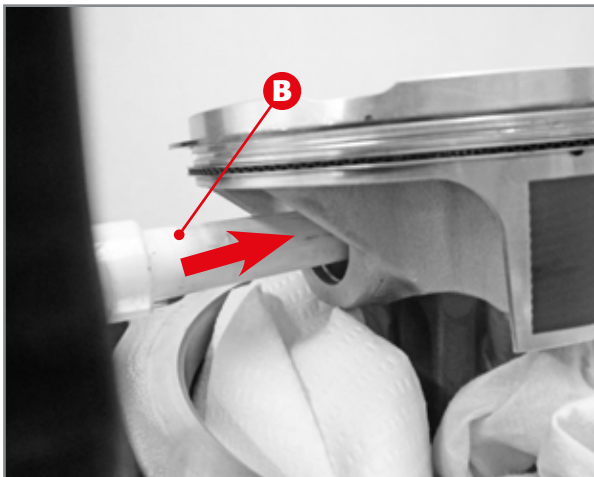

Removal of pin bolt.

2.1.5 DISASSEMBLING THE CYLINDER AND PISTON

Lift the cylinder **1** by a few centimetres, remove the two centring bushes **2** (both located on the chain side) to prevent them from falling inside the crankcases and continue removing the cylinder. Remove the cylinder gasket **3**.

Place a clean cloth between the piston and the crankcase to keep foreign objects or simple solid residue from falling inside the base. Using a suitable tool to insert the specific seat **A**, remove the elastic ring **4** on the right hand side of the piston **5**.

ATTENTION: *be careful not to drop the elastic ring inside the engine.*

From the left hand side of the piston, push the pin bolt with an aluminium cylinder **B** (or similar), until the pin bolt is freed from the foot of the connecting rod.

Remove the piston.

ATTENTION: *Try pulling out the pin bolt by hand first of all. If it is too tight, hit the pin lightly with a rubber hammer, at the same time holding the piston with your hand in order not to stress the connecting rod.*

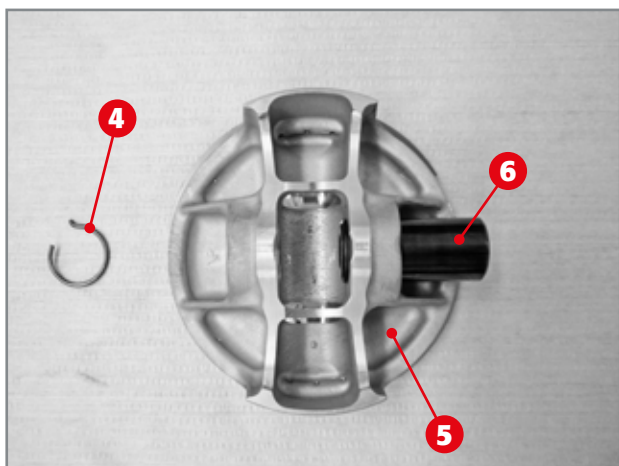

Bottom view of piston 5, elastic ring 4 and pin bolt 6.

In the figure you can see the piston 5 (bottom view), the circlip 4 and the pin bolt 6.

2.2 DISASSEMBLY OF IGNITION UNIT, TIMING CHAIN AND PADS

The ignition unit is made up of the flywheel (or rotor), the pick-up and the stator which is one with the flywheel cover.

2.2.1 STATOR AND FLYWHEEL

Remove the screw 1 which connects the gear lever 2 to the drive shaft.

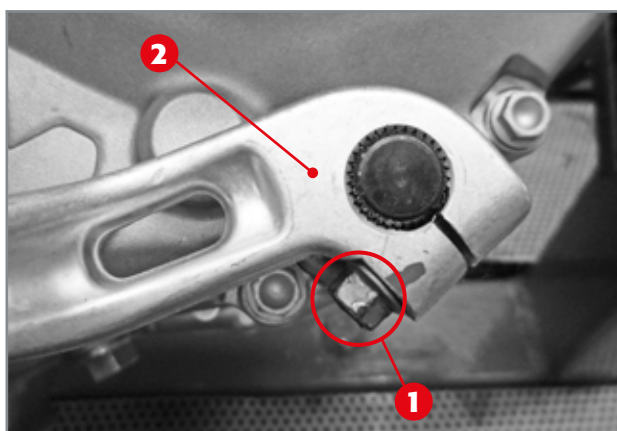

Removal of gear lever.

Remove the nine screws 3 which fasten the flywheel cover 4 to the left crankcase half. Remove the flywheel cover and the gasket placed between the crankcase and the cover.

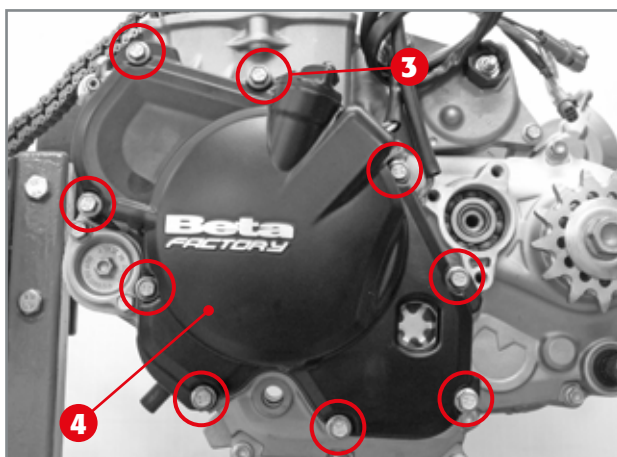

Fixing screws 3 of ignition cover 4.



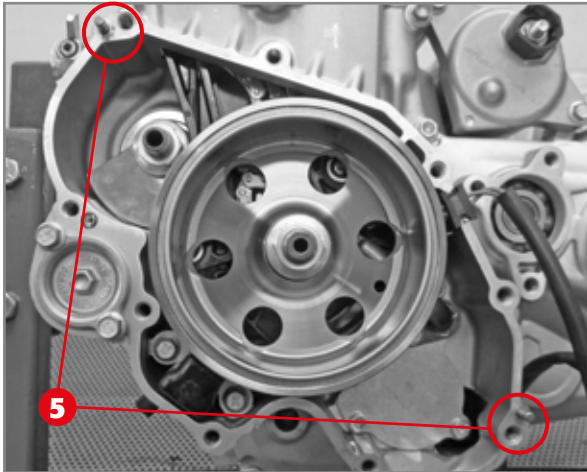

Two centring pins 5 dedicated to the flywheel cover (injection version).

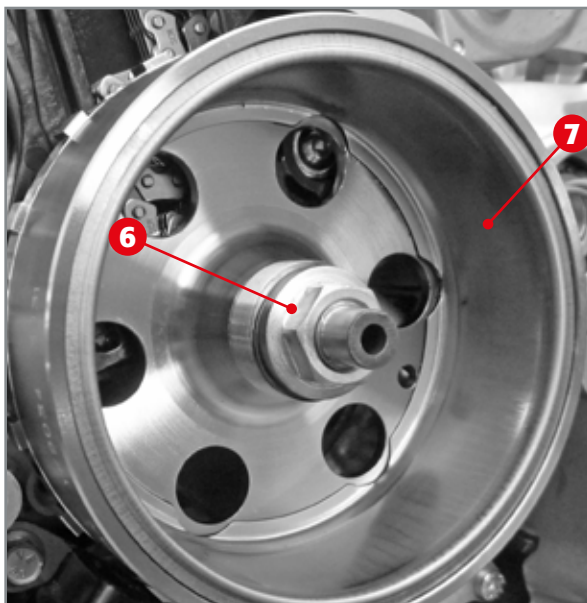

Nut 6 which fastens flywheel 7 to the crankshaft (injection version).

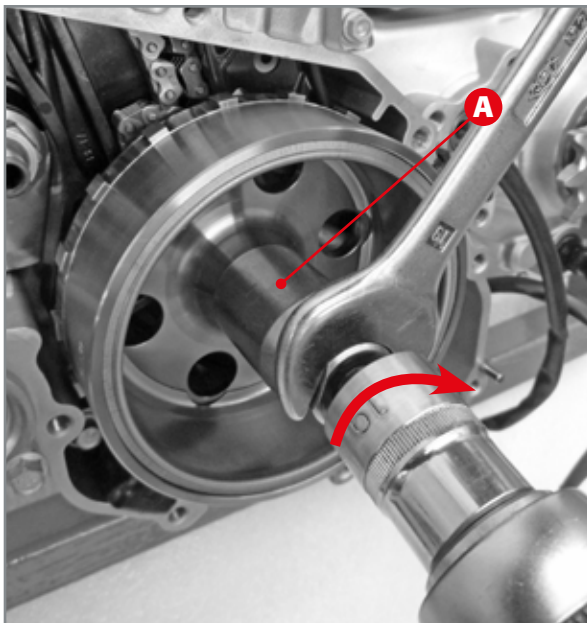

Starter flywheel removal (injection version) with special gear puller A.

Pay attention to the two centring pins 5 on the crankcase half.

Remove the tightening nut 6 which fastens the flywheel 7 to the crankshaft.

Once the nut has been unscrewed, pay attention to the special elastic washer (8 shown in the following images) placed between the nut and the flywheel.

To remove the flywheel, screw the relevant extractor A (code 3625173) onto the threaded segment on the flywheel and, using a box spanner, tighten the screw on the extractor.

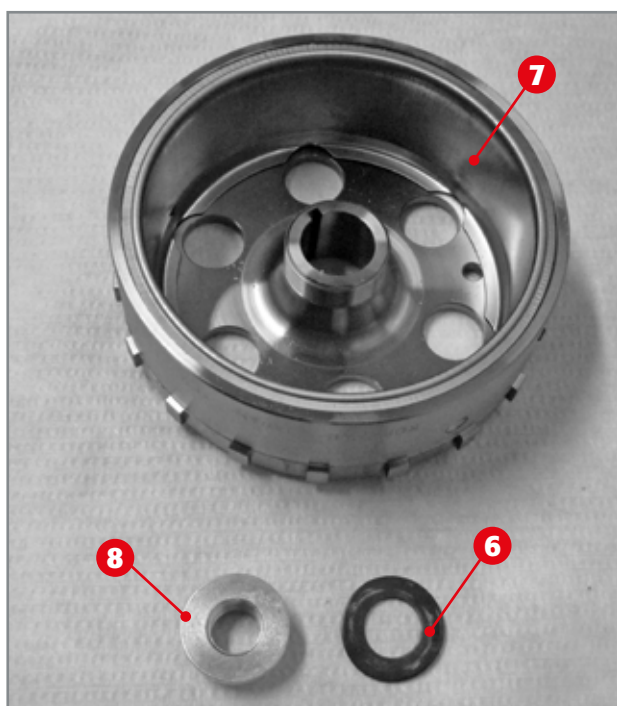

Flywheel 7, nut 6 and special rose-petal 8.

The image to the side shows the flywheel 7 (rear view), the special elastic washer 6 and the tightening nut 8.

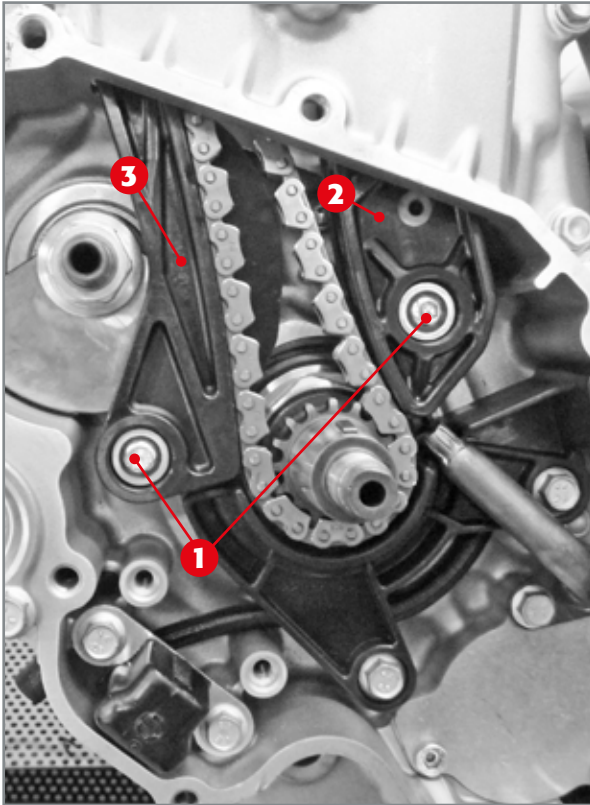

Fixing screws 1 of mobile 2 and fixed pad 3.

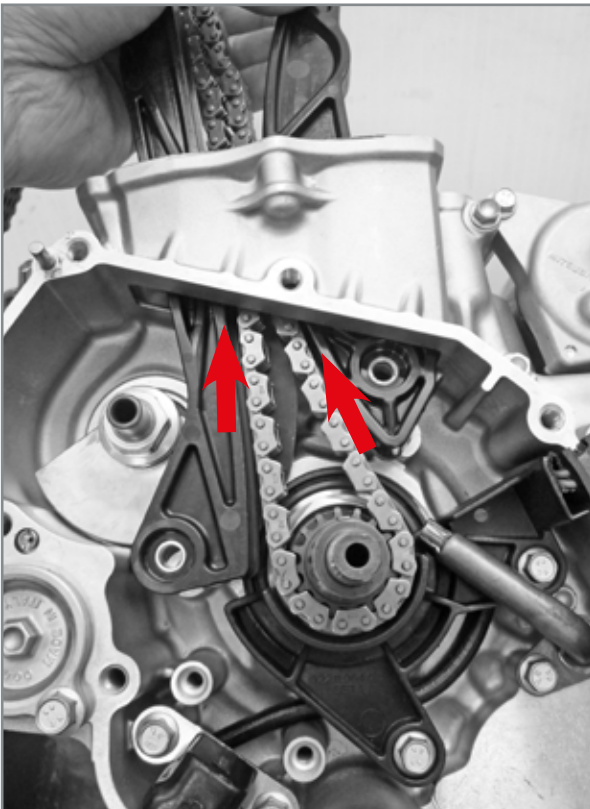

Extraction of chain pads.

2.2.2 TIMING CHAIN AND PADS

Remove the fixing screws 1 of the mobile 2 and fixed pad 3.
Extract pad 2, then pad 3, by pulling them upwards.

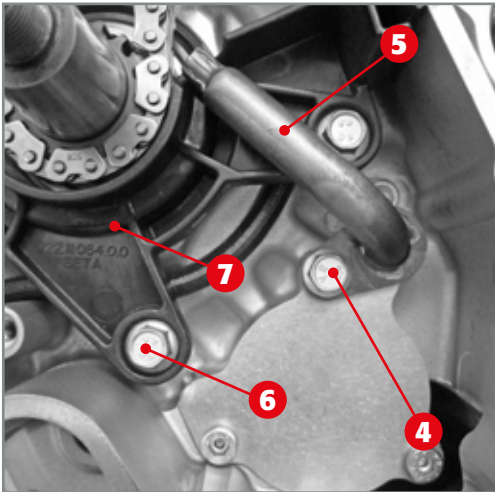

Chain guard and oil jet.

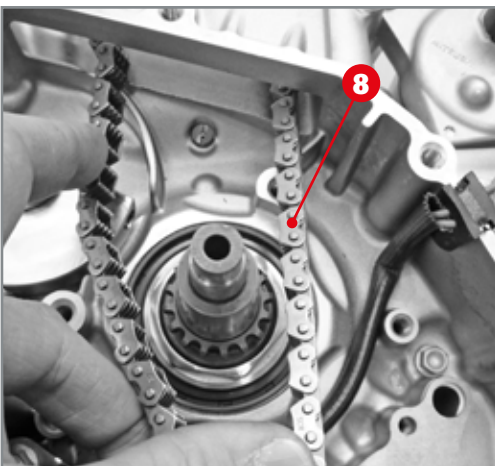

Removal of timing chain.

Remove the screw 4 and extract the oil jet 5. Remove the two screws 6 and then the chain guard 7. Pay close attention to the respective bushes while extracting the mobile and fixed pads and the timing chain.

Remove the timing chain 8, freeing it from the gear on the crankshaft and pull it downwards.

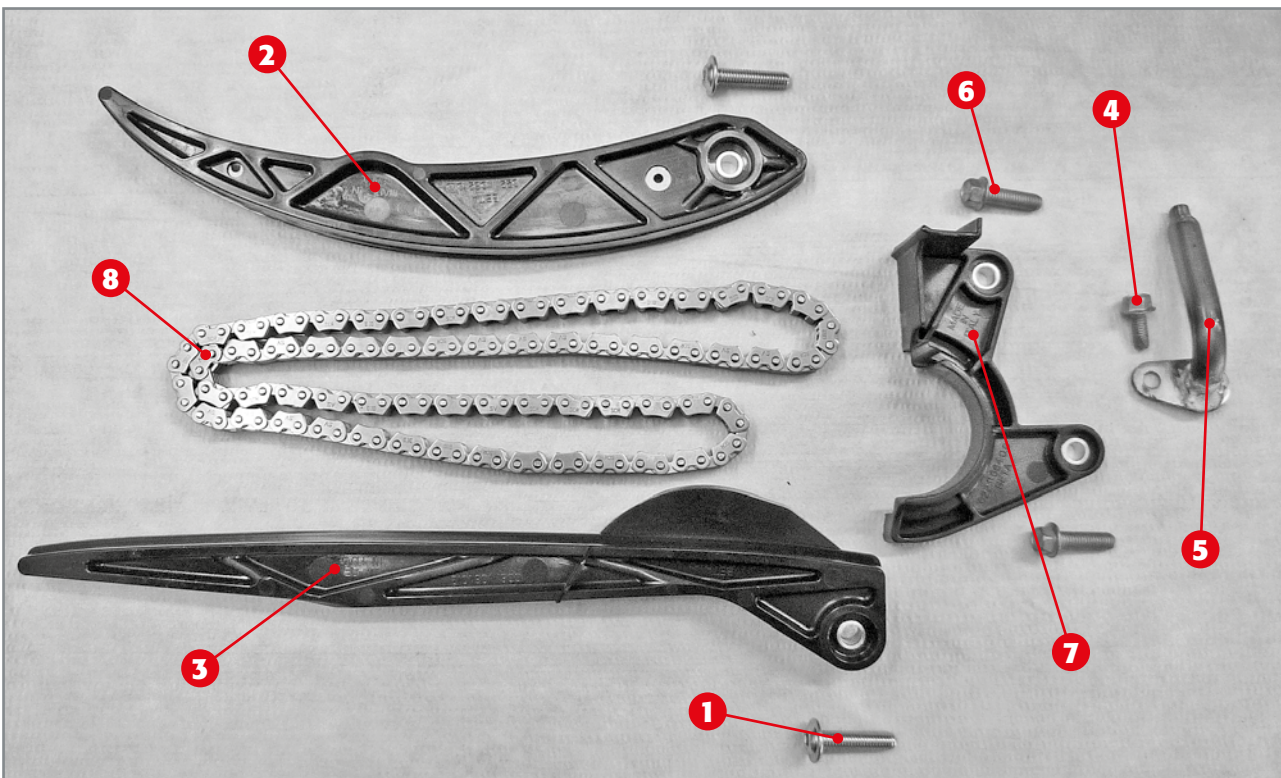

Two pad fixings screws 1; mobile pad 2; fixed pad 3; oil jet fixing screw 4; oil jet 5; chain guard fixings screws 6; chain guard 7; timing chain 8.

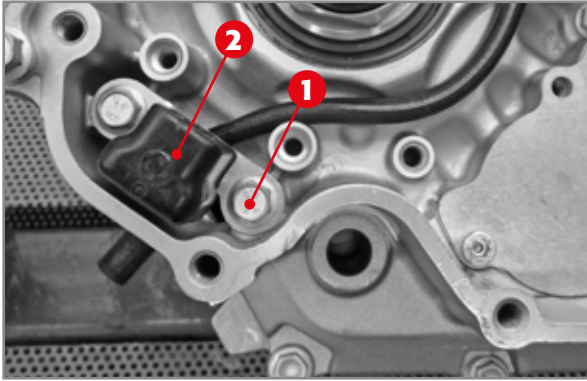

Two screws 2 for fixing pick-up 1.

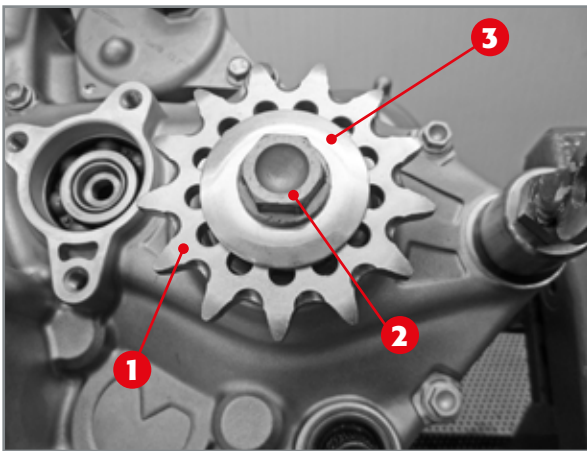

Pinion 1, screw 2 and washer 3.

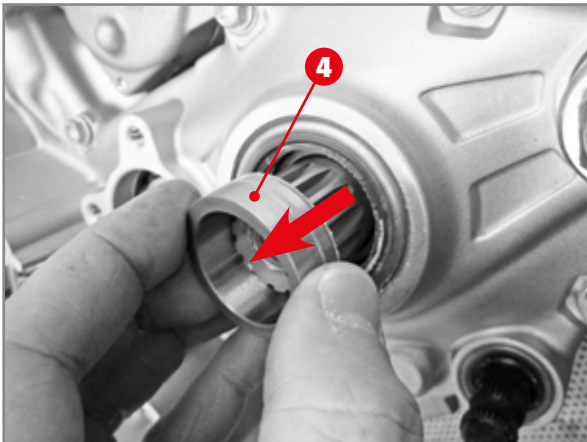

Pinion spacer 4.

2.2.3 PICK-UP

Once the timing chain guard has been removed, the pick-up 1 can be disassembled, by removing the two fixing screws 2.

2.3 PINION AND SPACER

In order to remove the pinion 1, loosen the screw completely 2 and take off the washer 3.

After removing the pinion, pull off the spacer 4.

2.4 CLUTCH UNIT AND COOLANT PUMP COVER

In order to access the clutch unit, the outer clutch cover **1** must be removed by loosening the screws **2**.

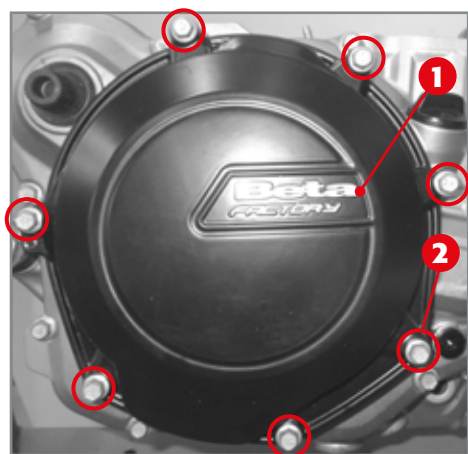

Outer clutch cover **1** and respective screws **2**.



Inner clutch cover **3** and respective screws **4**.

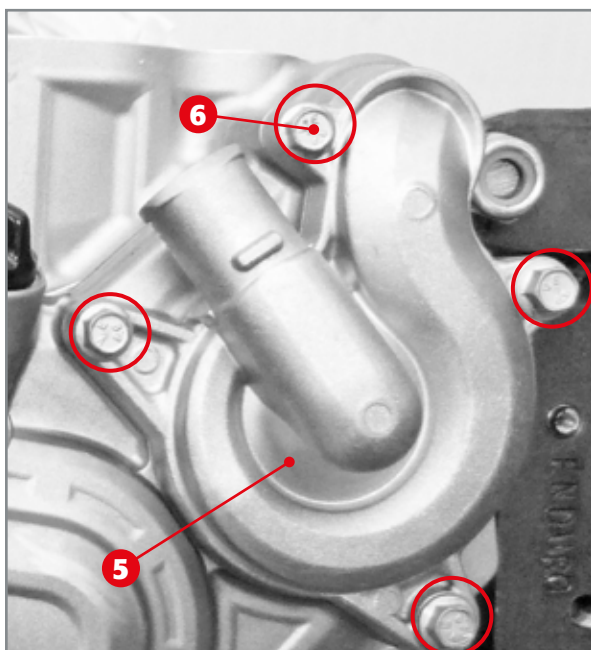

Pump cover **5** and respective screws **6**.

On the other hand, when doing a complete overhaul of the clutch unit, of the other elements housed in the outer right side of the crankcase half or of the engine, the inner clutch cover **3** must be removed by loosening the screws **4** and the water pump cover **5** loosening the screws **6**.

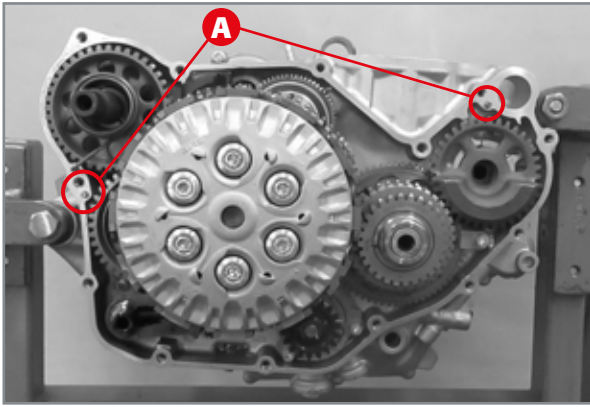

Two centring pins A for inner clutch cover coupling.

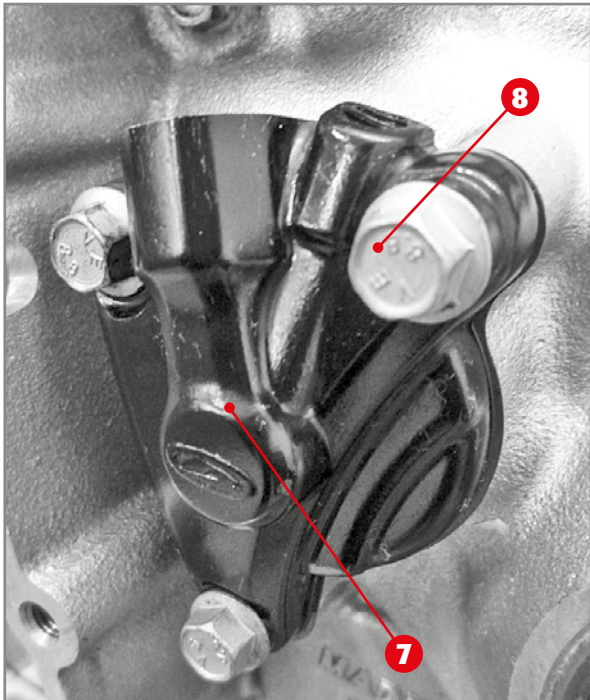

Hydraulic actuator 7 and three screws 8 for crankcase half coupling.

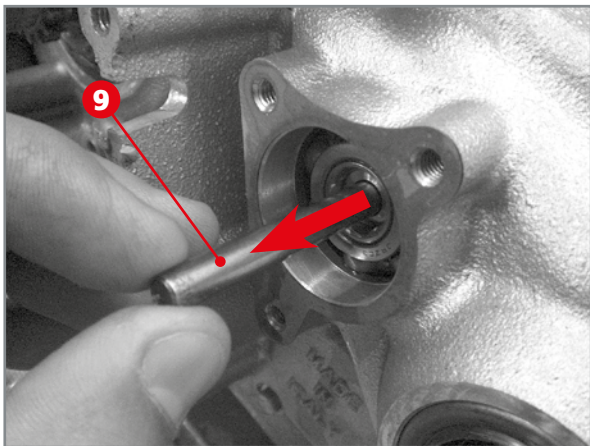

Extraction of clutch rod 9.

Pay attention to the two reference pins **A** placed between the right crankcase half and the inner clutch cover while disassembling.

If only the clutch actuator pipe was removed during the disassembly of the engine from the vehicle, remove the complete hydraulic actuator **7** from the outside left crankcase half by fully undoing the three screws **8** that secure it to the crankcase half. Remove the gasket in between the actuator and the crankcase half.

Extract the clutch control rod **9**.

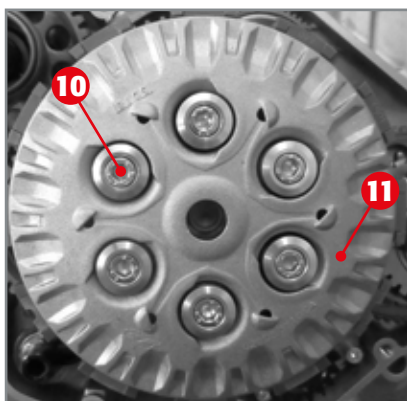

Clutch cap 11 and screws 10.

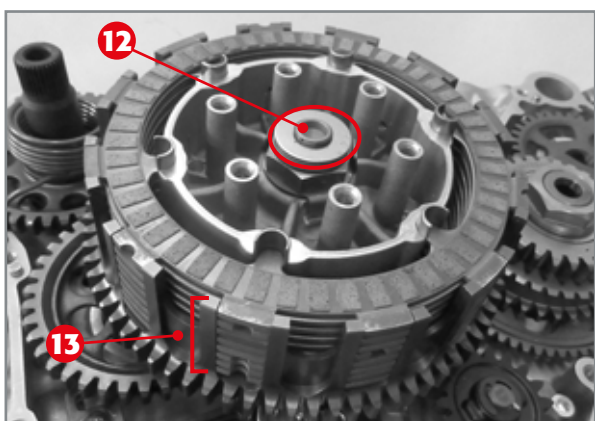

Pressure plate unit 12 and clutch disc pack 13.

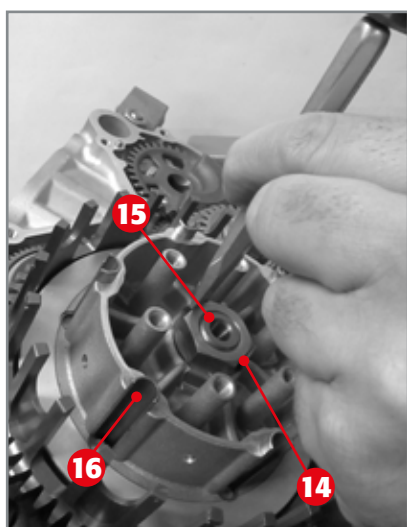

Opening safety washer with chisel.

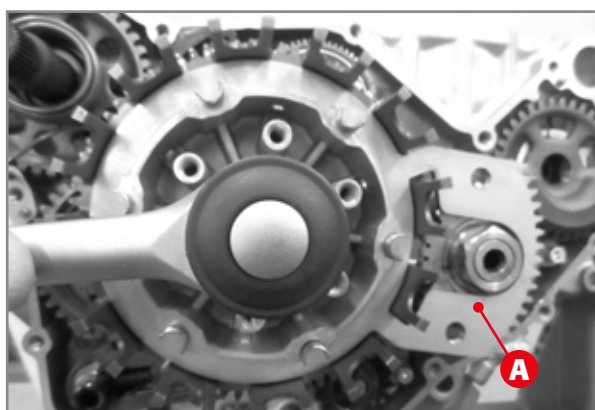

Removal of clutch drum nut with relevant tool A.

Remove the screws 10 which fasten the clutch cap 11 to the clutch drum.

Remove the clutch cap together with the four washers and relative springs.

Extract the complete pressure plate unit 12 and the clutch disc pack 13.

In order to complete the disassembly of the clutch unit, open the safety washer 14 using a chisel and remove the nut 15.

ATTENTION: Do not remove the sliding pins 16.

To unscrew the nut 15, the clutch drum must be blocked with a suitable tool A (code 029.14.002.50.00). Then remove the nut and relative safety washer.

ATTENTION: do not use the pneumatic gun.



Extract the clutch drum **17**, the washer **18**, the case **19**, the roller cage **20** and the centre bearing **21**. It is possible to remove the sliding pins **22**.

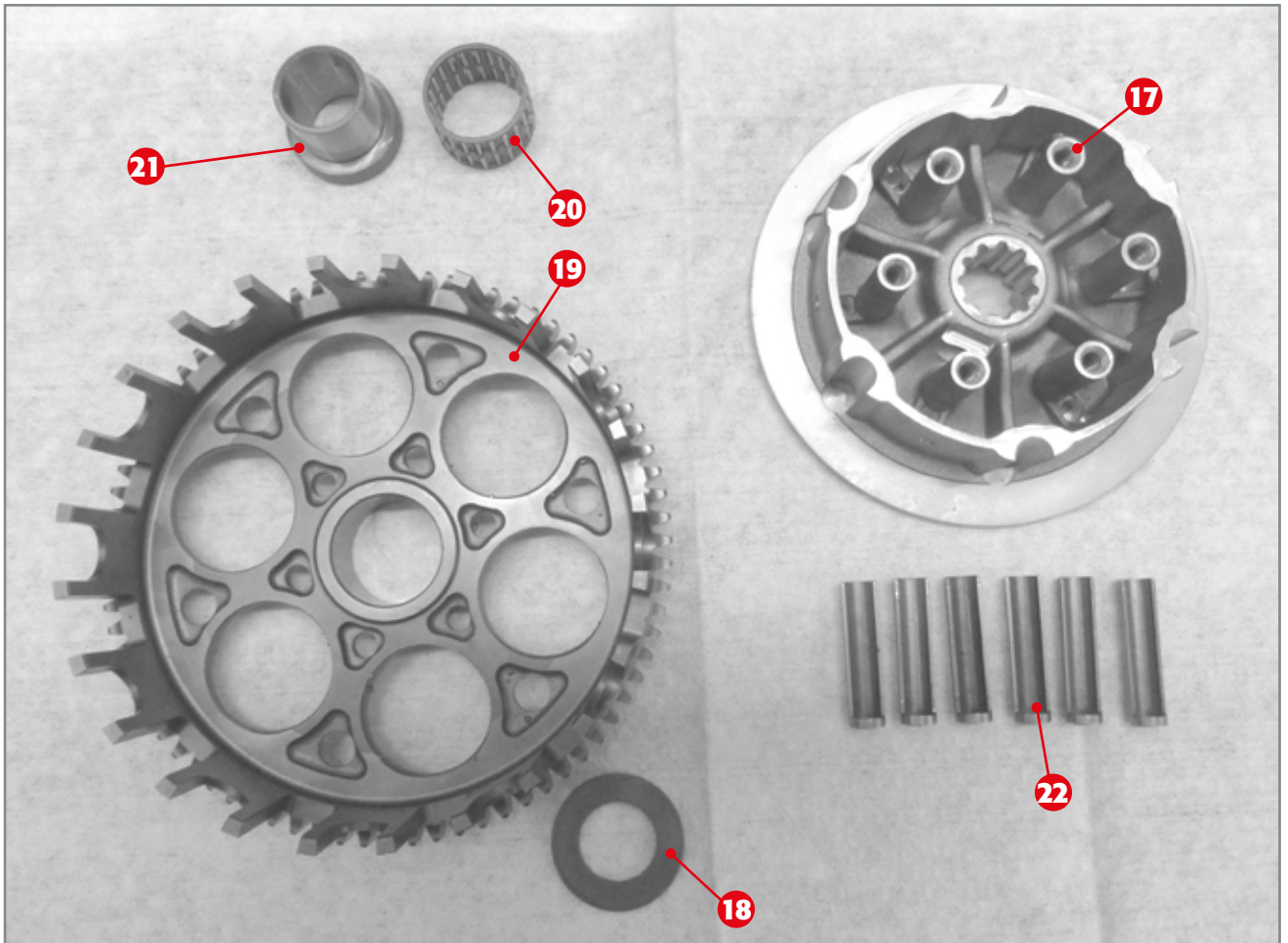

Washer **17**; case **18**; roller cage **19**; bushing **20**; special driven disc **21**; disc spring assembly **22**.

2.5 ENGINE LUBRICATION CIRCUIT

The high-pressure pump (or delivery) **1** - with less displacement - sends the oil purified by the paper filter **2**, to the crank mechanism **3**, to the piston oil jets **4**, to the tensioner **5** and to the cylinder head jets and camshafts* **6**. The valve **7** controls the pressure.

When oil has lubricated the cylinder head and has seeped through the tensioner, it flows along the timing chain to the ignition unit compartment **A**. When oil has lubricated the crank mechanism and the piston-cylinder coupling, it goes to the crank mechanism compartment **B** from which it is sucked by a low-pressure pump (or recovery) **9** - with higher displacement -, passing through the oil filter **8** and sent to the ignition unit compartment **A**. There it is sucked once again by the pump **1** after being filtered through the wire metal filter **11**.

The valve **10** controls the pressure between the external casing on the ignition unit side and the crank mechanism compartment.

ENGINE LUBRICATION CIRCUIT:

- 1) High-pressure pump;
- 2) Paper oil filter;
- 3) Crank mechanism;
- 4) Piston oil jets;
- 5) Hydraulic tensioner;
- 6) Cylinder head oil jets;
- 7) High-pressure valve;
- 8) Internal filter;
- 9) Low-pressure pump;
- 10) By-pass valve;
- 11) Wire metal filter;
- A) Ignition unit compartment;
- B) Crank mechanism compartment.

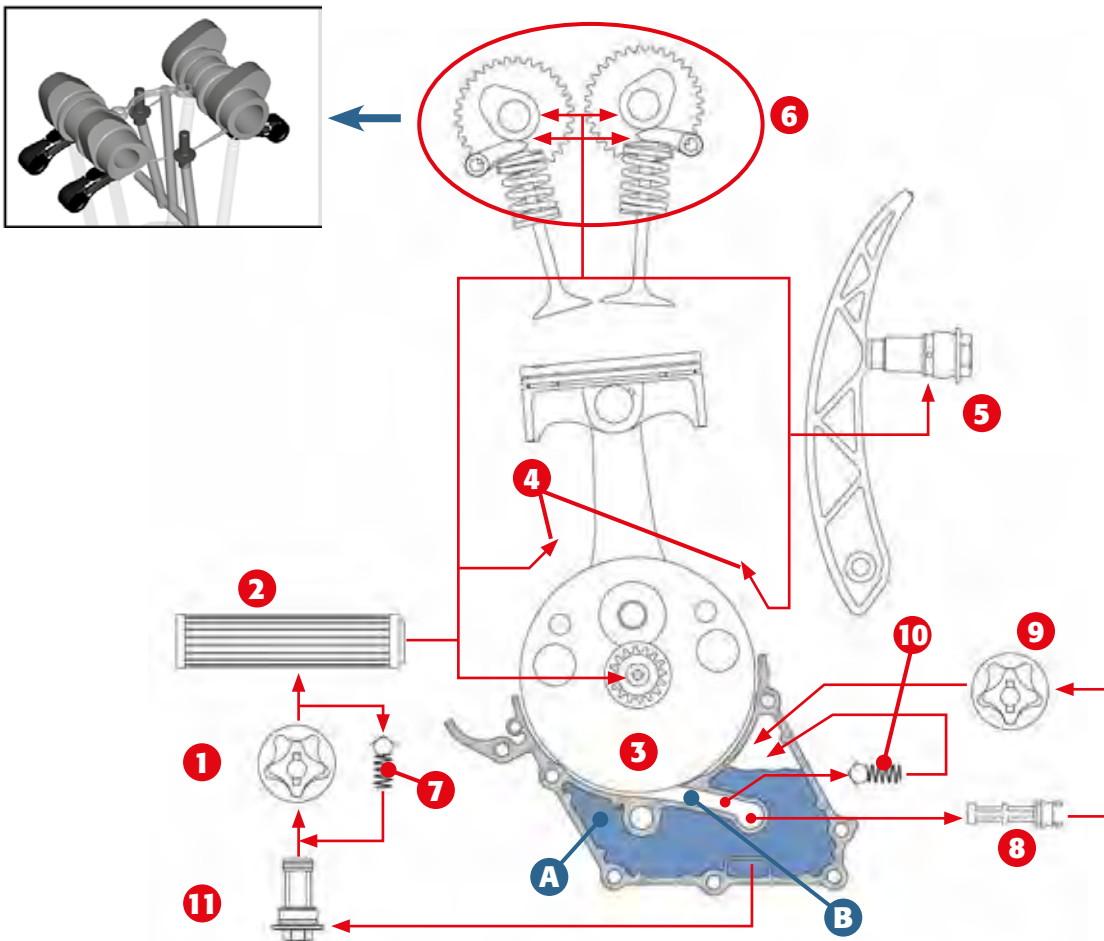

* Part of the lubricant sent to the cylinder head is used for the hydrodynamic support of the camshafts.

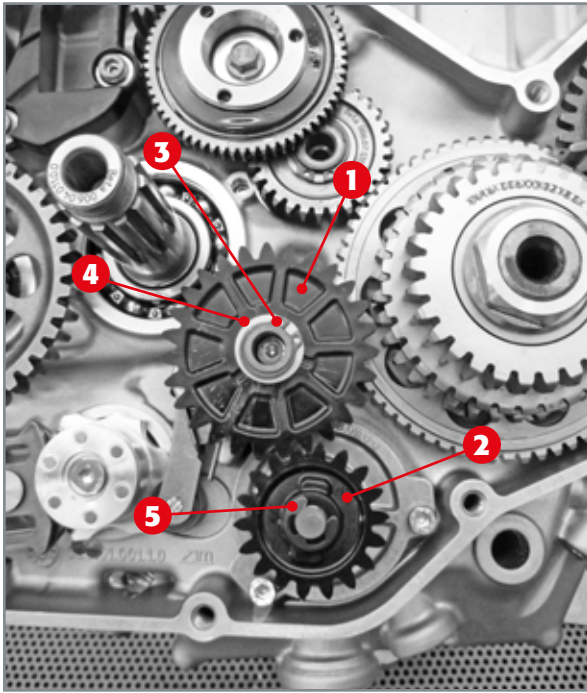

Gear unit for oil pump control.

- 1) Gear meshing with clutch gear;
- 2) Idler wheel
- 3) Oil pumps control gear;
- 4) Circlip;
- 5) Thrust washer;
- 6) Benzing ring

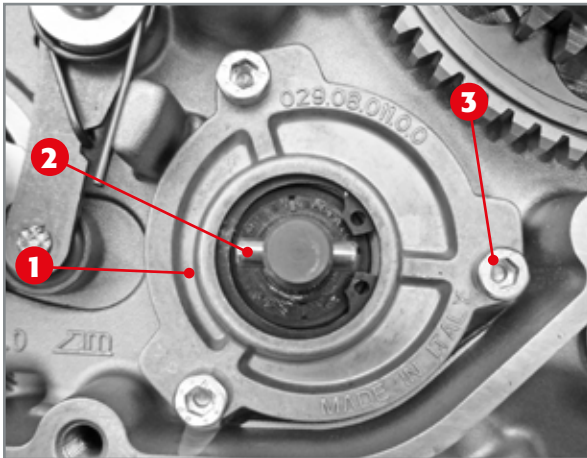

Disassembly of high-pressure pump cover.

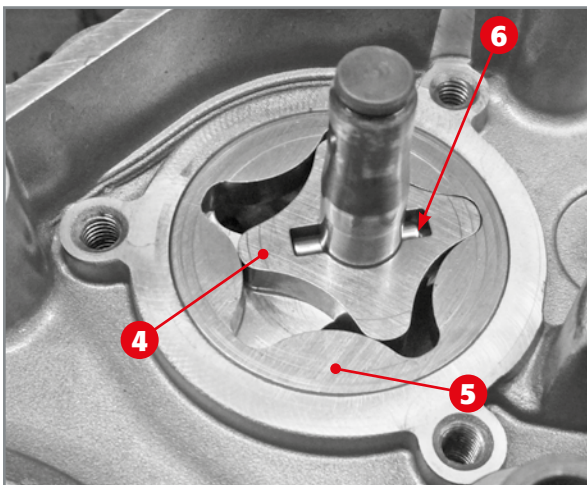

High-pressure pump. 4) Internal rotor; 5) External rotor; 6) Roller.

2.5.1 OIL PUMPS CONTROL GEARS

The two oil pumps are controlled by a gear unit driven by the clutch gear.

In detail, the gear 1 engages with the clutch case, and 2 is the oil pump control gear.

To dismantle the gear 1, remove the circlip 3 and thrust washers 4 (one below the gear).

To disassemble the gear 2, simply remove the Benzing ring 5.

2.5.2 HIGH-PRESSURE OIL PUMP

The high-pressure pump, located in the external right crankcase half, is enclosed under the cover 1 which can be disassembled by removing the roller 2 and the three screws 3.

After having removed the cover, extract the internal rotor 4, the external rotor 5 and the roller 6.

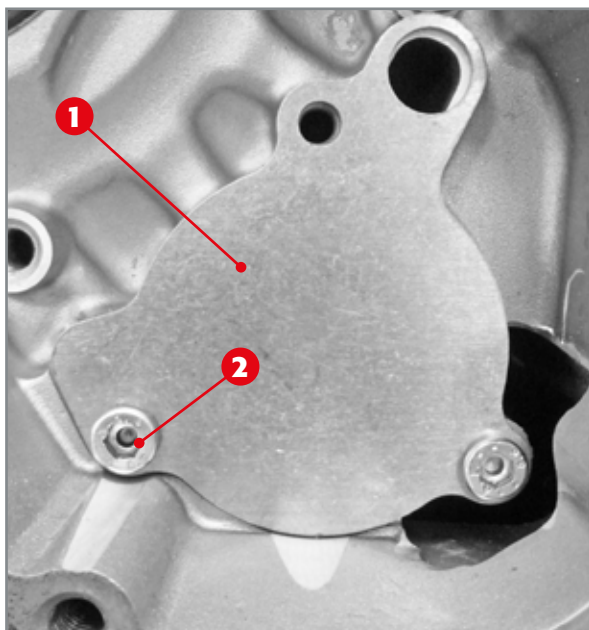

Cover and screws of low-pressure pump.

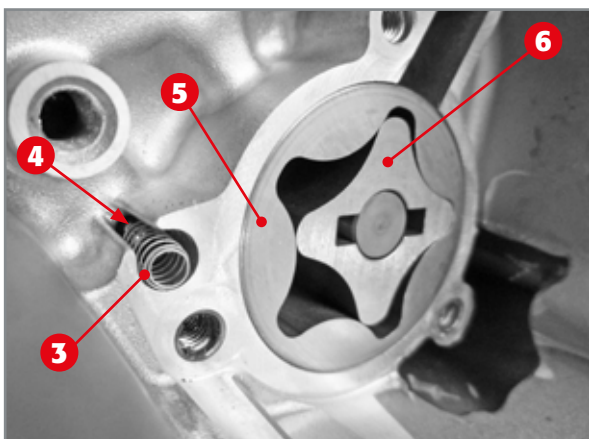

Low-pressure oil pump and by-pass valve.

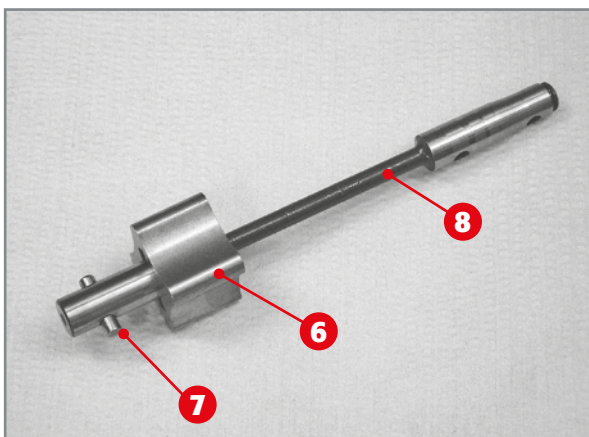

Internal rotor 6, roller 7 and drive shaft 8.

2.5.3 LOW-PRESSURE OIL PUMP AND BY-PASS VALVE

The low-pressure pump and the one-way valve are located in the left crankcase half (on the outside) inside the ignition unit compartment. They are enclosed under the cover 1, which is removed by removing the two screws 2.

Extract the one-way valve consisting in the spring 3 and the ball 4. Then extract the external rotor 5 and the internal rotor 6 together with the roller 7 and the drive shaft 8.

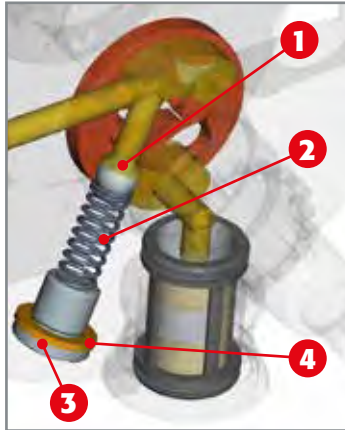

Pressure control valve layout.

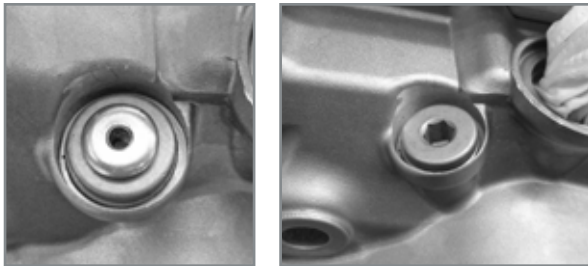

Rivet on pressure regulator. Pressure regulator.

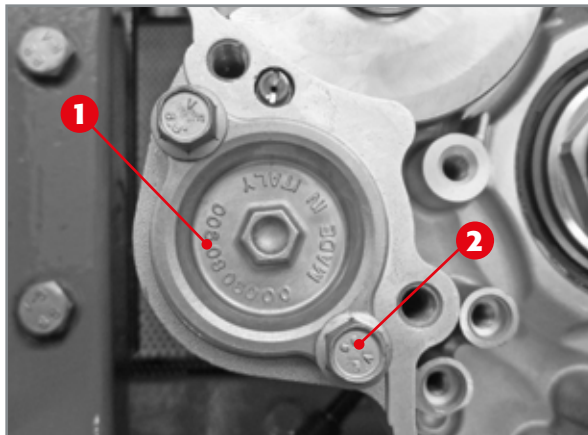

Paper oil filter cap 1 and relative fixing screws 2.

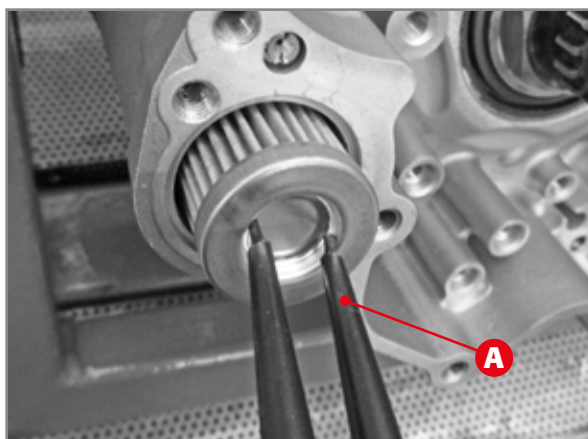

Extraction of filter with pliers A.

2.5.4 OIL PRESSURE CONTROL VALVE

The pressure control valve is located in the bottom of the right-hand side crankcase near the motor oil drain plug.

The valve consists of the ball 1 and the spring 2 kept in place by the screw 3 and washer 4. To dismount, simply remove the protection rivet with a 6mm drill tip.

ATTENTION: protect the mechanical parts from any shavings.

In order to disassemble the valve, remove the screw, pull out the washer, the spring and the ball.

2.5.5 PAPER OIL FILTER

In order to extract the paper oil filter, remove the cover 1 by loosening the two screws 2 completely. Once the cover has been removed, use a pair of opening pliers A to extract the filter.

While extracting the cover, be careful of the specific O-ring applied onto the cover.

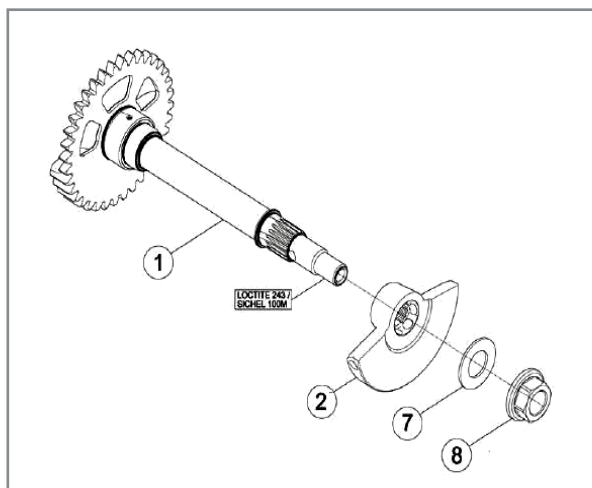

Exploded view of countershaft.

- 1) Shaft;
- 2) Counterweight;
- 7) Elastic washer
- 8) Nut M12x1.



Extraction of countershaft.

2.6 COUNTERSHAFT

The countershaft has the task of balancing a part of the inertial forces produced by the crank mechanism.

The countershaft is mainly made up of the shaft 1 and counterweight 2. The elastic washer 7 and nut 8 have the task of assuring coupling of the complete shaft to the base.

ATTENTION: do not use the pneumatic gun.

In order to disassemble the shaft, remove the nut 8 which can be accessed through the ignition unit compartment. Extract the elastic washer 7 and the counterweight.

Pull the countershaft out through the right-hand side crankcase 1.

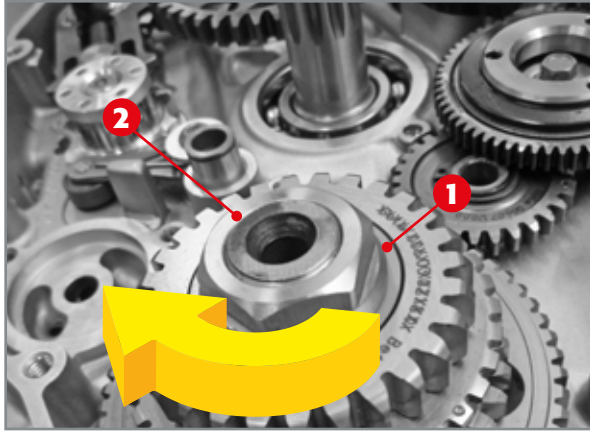

Primary gear 1 and relative nut 2.

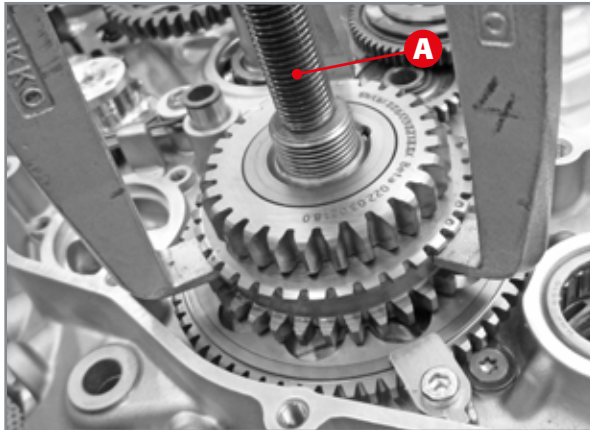

Extraction of primary gear with appropriate extractor A.

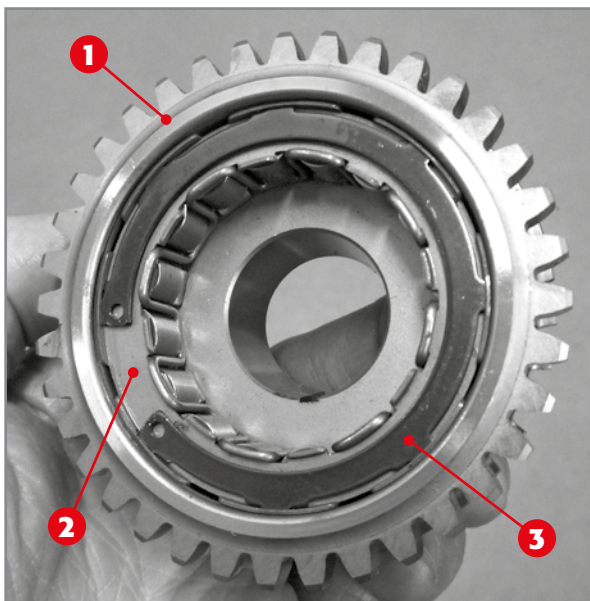

Primary gear 1, complete with free wheel 2 and specific circlip 3.

2.7 PRIMARY GEAR

The primary gear 1, located in the right crankcase half, is fastened to the crankshaft. In order to disassemble it, remove the nut 2 which must first be previously heated using a blow-dryer or similar instrument.

ATTENTION!

The nut 1 must be turned clockwise to be unscrewed.

Extract the primary gear using the relevant extractor A. (code 006140150000)

Notice that the primary gear houses the free wheel device 2 inside it, which can be removed by taking out the circlip 3.

2.8 ELECTRIC IGNITION

Electric ignition can be carried out by means of the start motor **1** which engages on the gearwheel **4** with the function of torque limiter.

The gearwheel **4** (torque limiter) transmits motion to the idler wheel **7**, which will then engage with the starter gear **9**.

The roller bearing **10** supports the starter wheel **9**, while the free wheel **11** is internally engaged on the starter wheel **9** and externally on the primary gear, thus allowing it, depending on rotation direction, to pull the crankshaft.

EXPLODED VIEW OF ELECTRIC KICKSTART.

- 1) Start motor;
- 4) Torque limiter;
- 7) Idler wheel;
- 9) Ignition gear;
- 10) Roller bearing HK2516;
- 11) Free wheel.

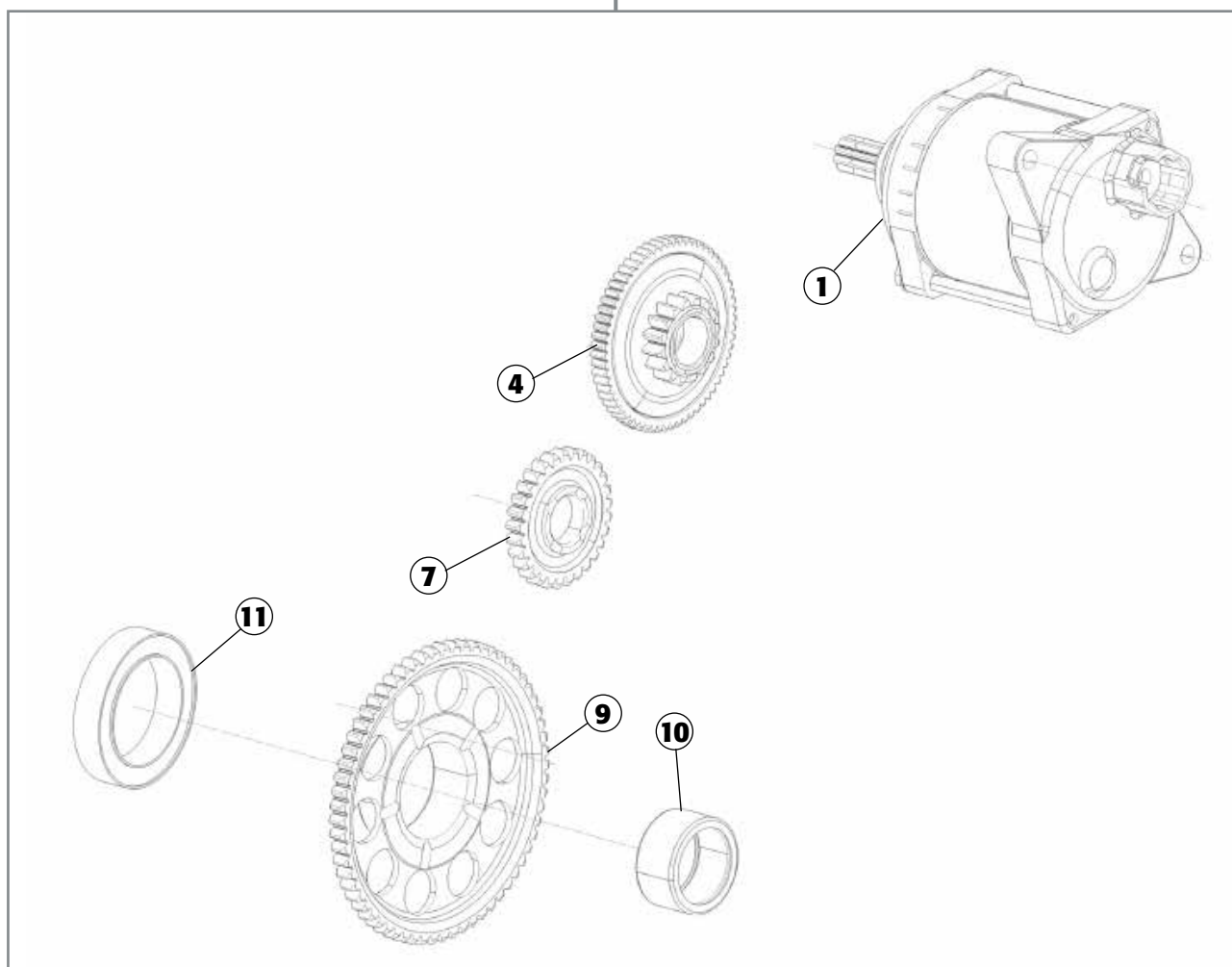

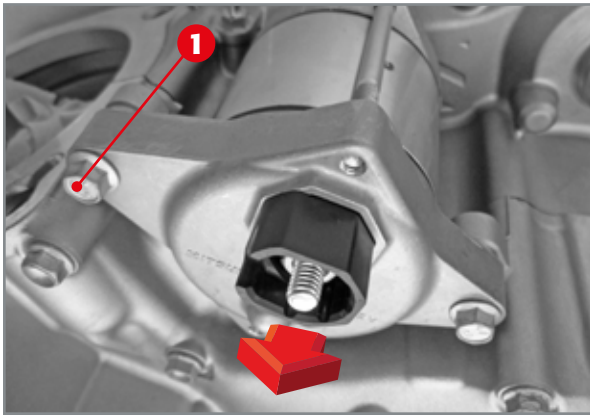

Screws 1 fixing start motor to crankcase.

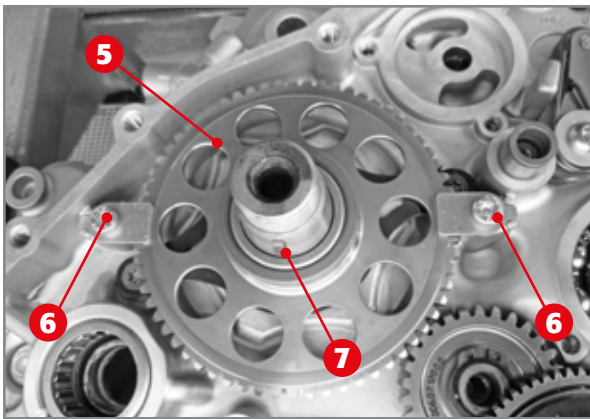

Removal of pin 6.

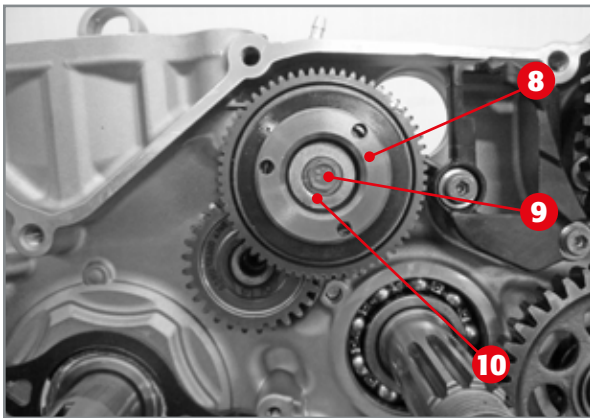

Torque limiter 9, screw 8 and washer 10.

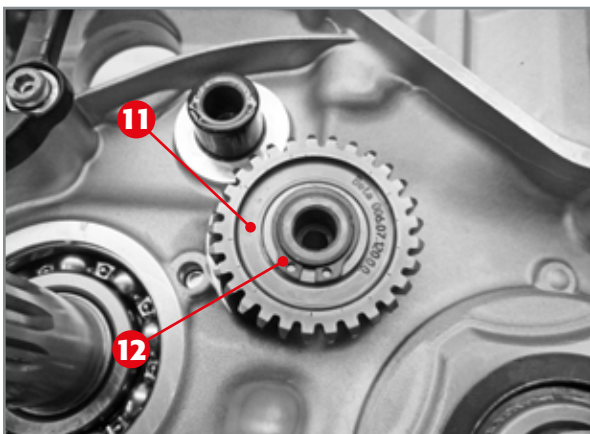

Idler wheel 11 of electrical ignition device.

2.8.1 ELECTRIC KICKSTART UNIT

Remove the two screws 1 which fasten the start motor to the crankcase and pull out the start motor.

To extract the kick-start gear 5, disassemble the primary gear (see par. 2.7), the safety stops 6 and key 7. The kickstart gear is pulled out by hand.

In order to disassemble the torque limiter 8, completely loosen the screw 9 which fastens the torque limiter to the crankcase. Pull out the washer 10 together with the limiter itself.

In order to remove the idler wheel 11, just remove the circlip 12 and pull out the gear.

2.9 PEDAL KICKSTART - OPTIONAL

The kickstarter is made up of the pedal which, attached to the kickstarter shaft 1, moves the kickstarter gear 2. This gear moves the idler wheel 3 which then engages with the clutch case. The device moves back thanks to the spring 4.

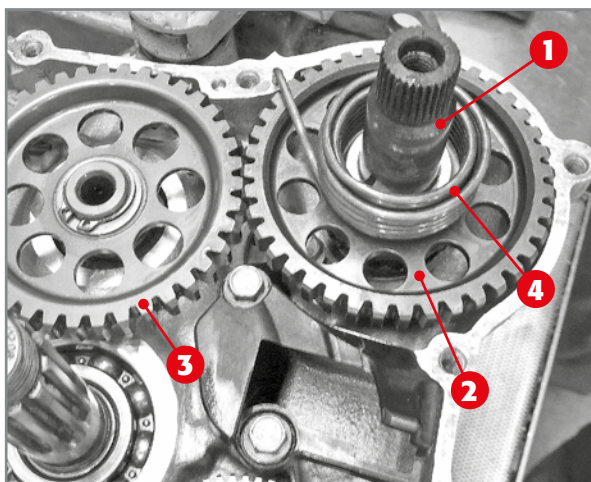

The pedal kickstart.

Remove the circlip 5 and pull off the external thrust washer 6, the idler gear 3, the internal thrust washer 7 and the second circlip 8. The circlips and thrust washers are interchangeable.

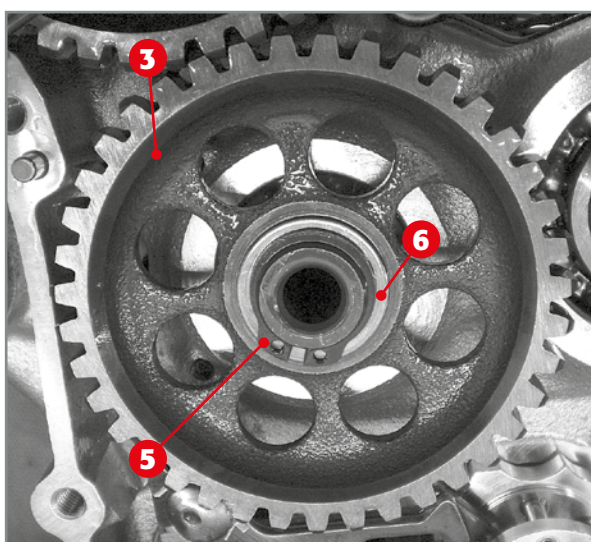

Removal of circlip 5 of idler gear 3.

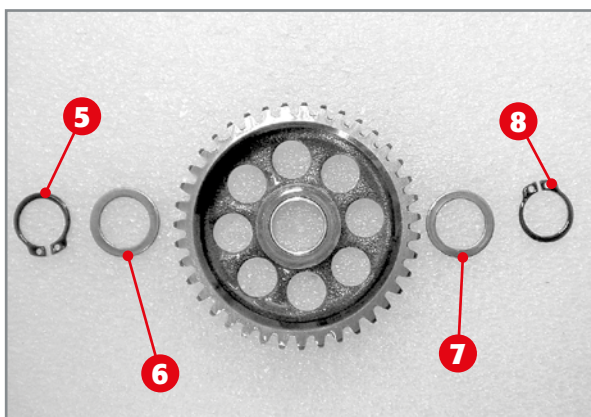

Two circlips 5 and 8 and thrust washers 6 and 7.

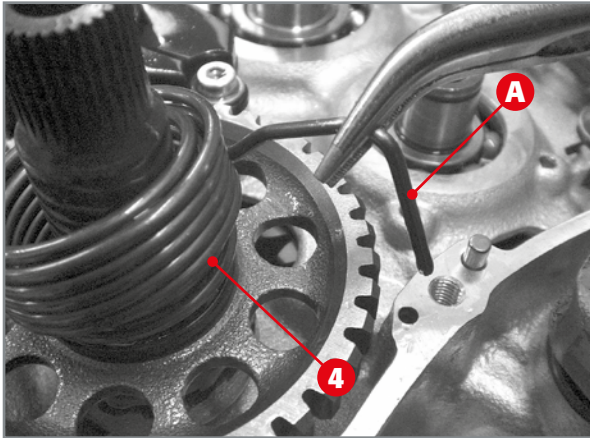

Releasing spring from crankcase.

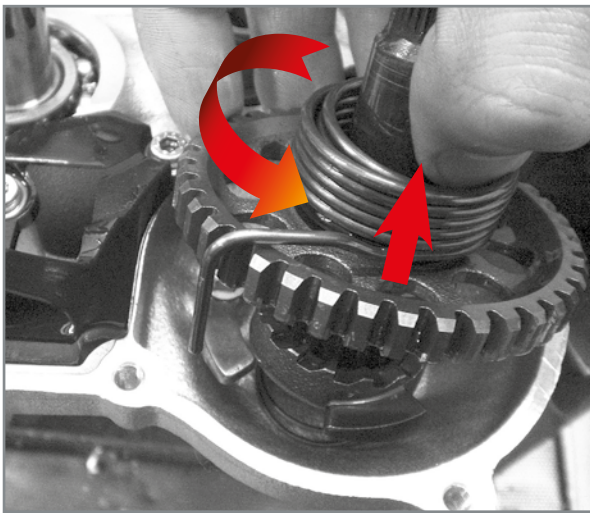

Extraction of shaft from crankcase.

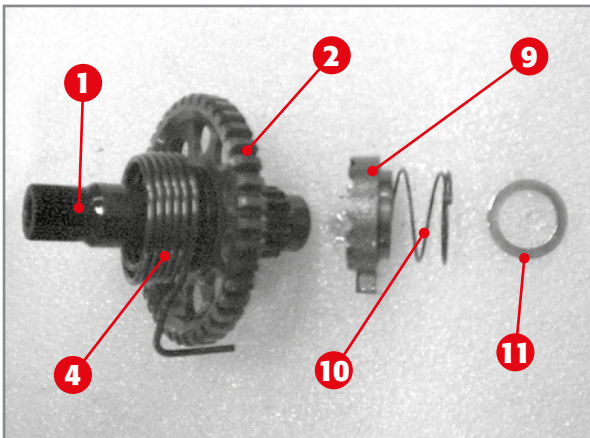

Complete manual kickstart shaft.

Using a pair of pliers, pull the end **A** of the spring **4** from the hole on the crankcase and bring it to a rest position having it turn anti-clockwise.

Turn the shaft anti-clockwise and pull it off together with the sleeve **9**, the spring **10** and the thrust washer **11**.

Note: pay attention to the reference pins for centring the inner clutch cover (par. 1.4)

2.10 EXTERNAL GEARSHIFT UNIT

The external gearshift is made up of the drive shaft **1** upon which the movable and fixed pawls are applied. The fixed pawl constitutes the guide of the movable pawl which has the task of engaging the stop cam **2**. This in turn is fastened to the internal gearshift and is kept in the fixed position by the cam stop lever.

In order to disassemble the drive shaft, just keep the movable pawl return spring **3** pressed and extract the shaft together with specific washer **4**.

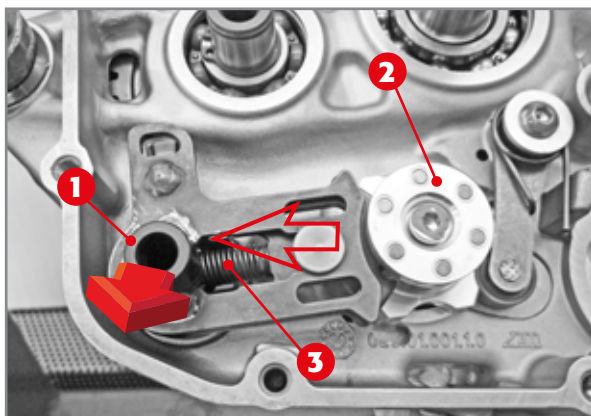

Crankshaft disassembly.

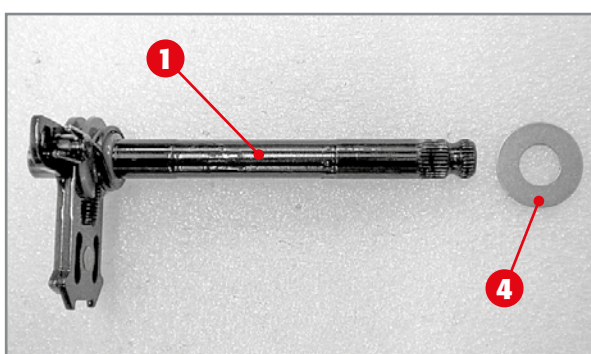

Gearshift with washer.

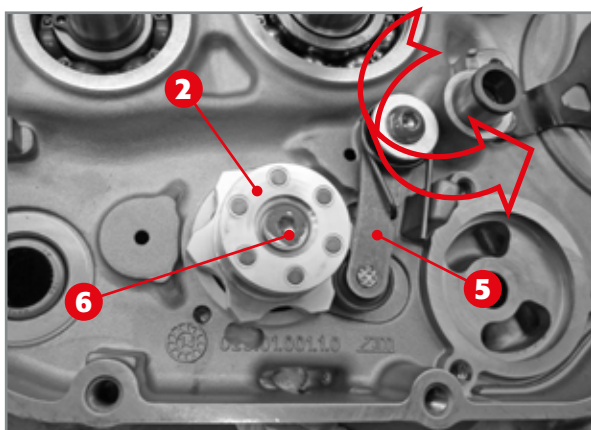

Disassembly of stop cam.

In order to disassemble the stop cam **2**, keep the cam stop lever moved **5**, loosen the screw **6** and pull out the stop cam.

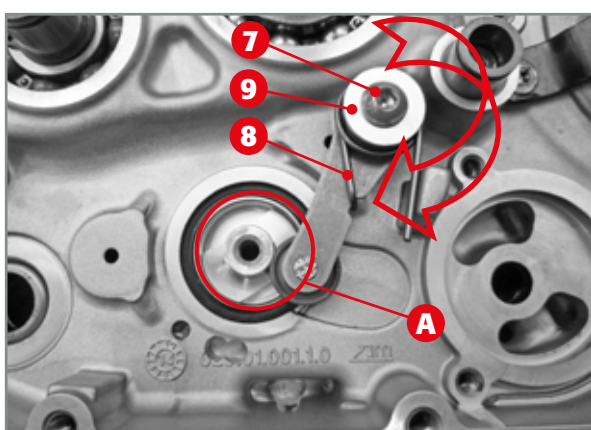

Disassembly of cam stop lever.

In order to disassemble the stop lever, loosen the screw **7** enough to allow the lever to move axially and overcome the cylinder segment **A** of the desmodromic device. Bring the return spring **8** to the rest position and remove the screw, the washer **9**, the spring together with the spacer (not shown in the image) and finally the cam stop lever.



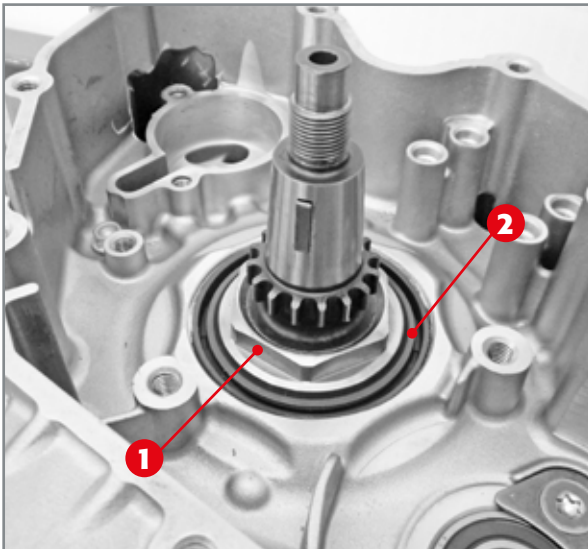

Nut B blocking crankshaft.

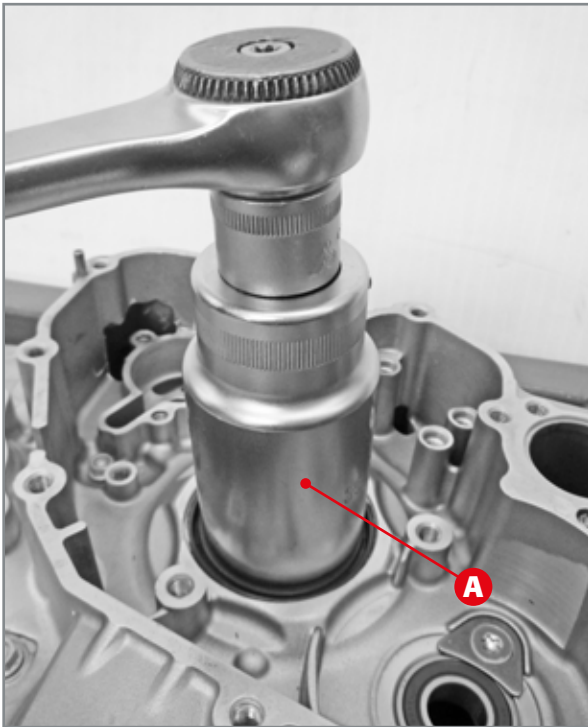

Removal of crankshaft nut with special socket wrench A.

2.11 CRANKSHAFT, GEARBOX UNIT AND INTERNAL GEARSHIFT

To access the crankshaft, gearbox unit and internal gearshift, the left and right crankcases must be detached. Here are the needed instructions.

2.11.1 NUT ON LEFT SIDE OF CRANKSHAFT

In order to loosen the nut **1** on the left-hand side of the crankshaft, heat it with a blow-dryer or similar instrument. Then loosen the nut with a special socket wrench **A** (code 006140020000) and remove it.

ATTENTION: When re-assembling, the oil seal must be replaced **2** since the heating required for disassembly damages it.

2.11.2 OPENING THE CRANKCASE

Remove the 13 locking screws **1** on the left side casing and the 4 screws **2** on the right side casing.

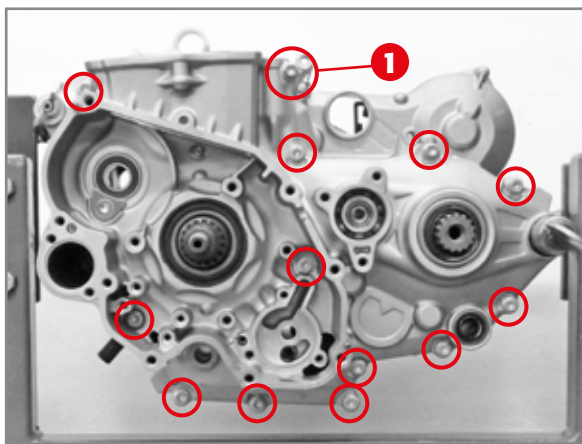

Screws 1 for blocking left side casing.

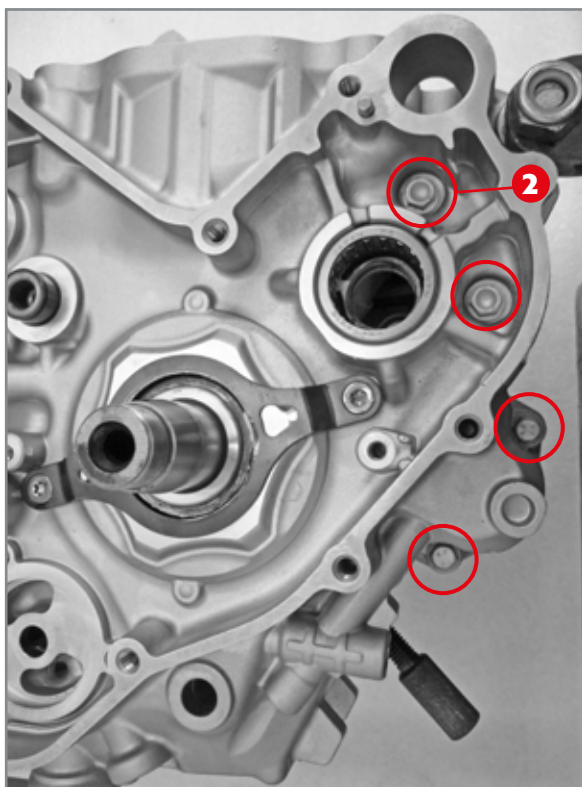

Screws 2 for blocking right side casing.

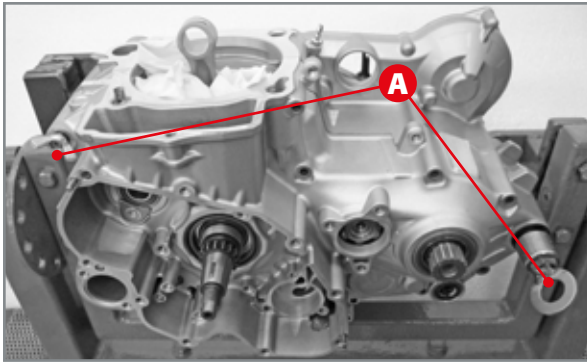

Two screws A blocking engine to engine support stand.

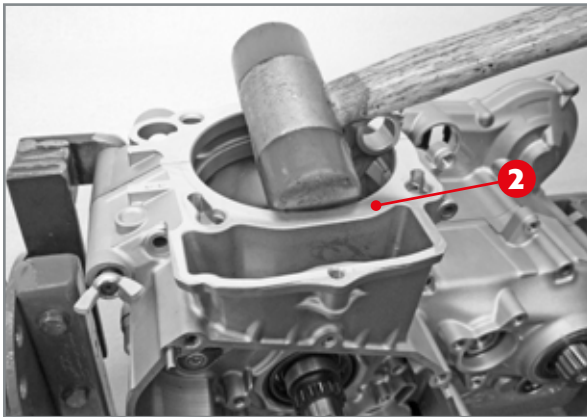

Disassembly of crankcase.

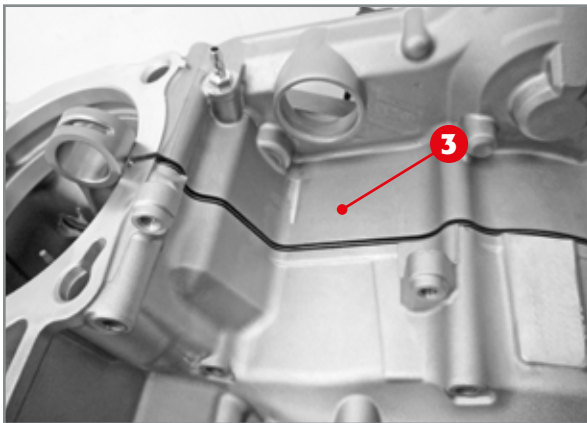

Detaching crankcase halves.

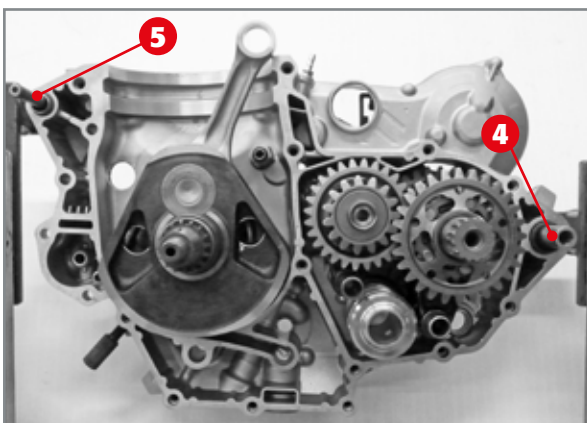

The left crankcase half (inside) with references pins 4 and 5.

Loosen the two screws **A** which fasten the engine to the support stand.

Hit the left crankcase half **2** gently with a rubber or plastic hammer until it detaches from the right crankcase half **3**. Remove the two screws blocking the engine to the equipment and disassemble the crankcase by hand.

ATTENTION: The gearbox unit and the crankshaft must remain inside the right crankcase half.

Remove the back **4** and front reference bushes **5** to position the crankcase correctly. Remove the gasket between the two half-casings.

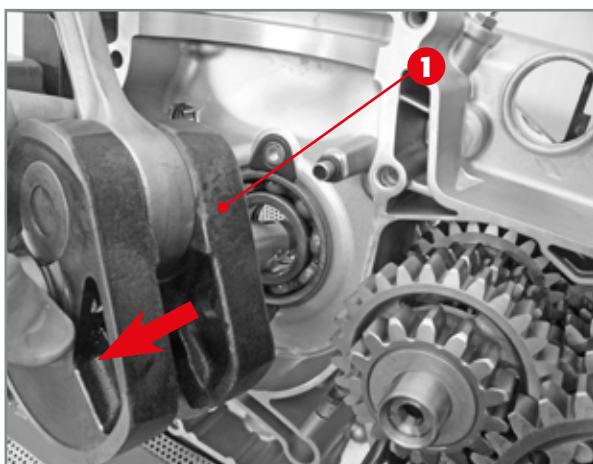

Extract the forks together with the drive bushes.

2.11.3 CRANKSHAFT

Remove the crankshaft fixing screw.
The crankshaft **1** can be pulled out by hand. Should there be resistance, tap the right end of the crankshaft lightly with a plastic or rubber hammer.

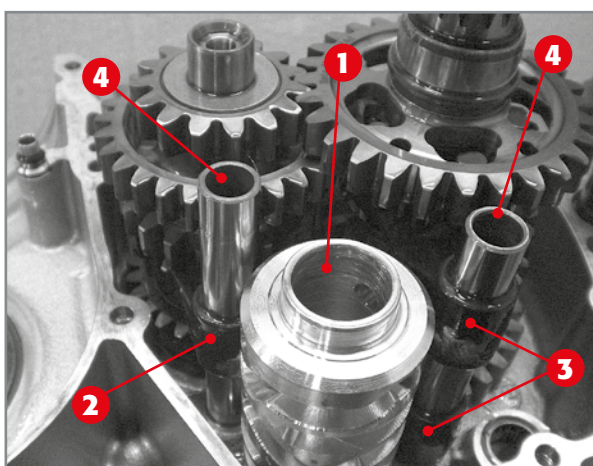

Removal of fork support pins **4**.

2.11.4 INTERNAL GEARSHIFT UNIT AND COMPLETE GEARBOX

The internal gearshift unit is made up of the desmodromic device **1** upon which the fork **2** and two forks **3** are engaged. The forks, supported by the pins **4**, drive the sliding wheels of the gearbox, allowing engagement of the desired ratio. The forks, supported by the pins **4**, drive the sliding wheels of the gearbox, allowing engagement of the desired ratio. The desmodromic device is controlled by the stop cam present in the external gearshift unit (par.2.10). Extract the two pins **4** by hand so that the forks can be released and removed.

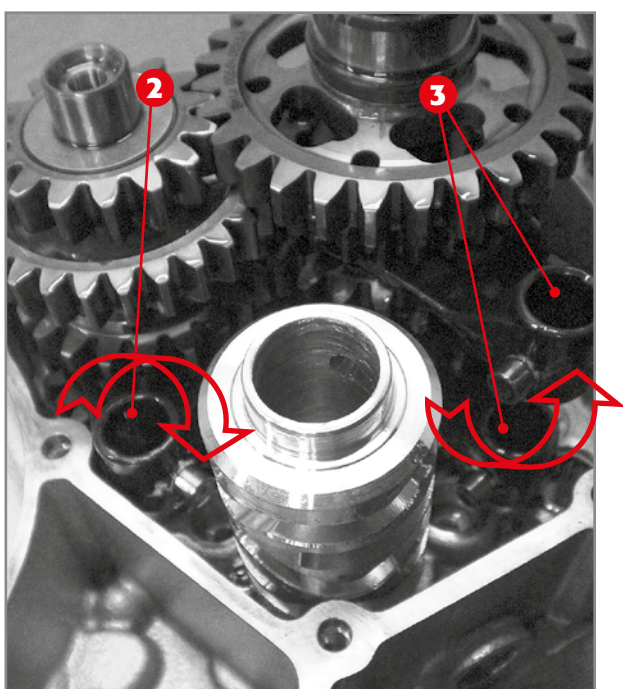

Disengaging of drive forks from the desmodromic device.

Turn the fork **2** which drives the sliding gear on the primary unit clockwise, to free it from the desmodromic control.

Do the same operation, though in the opposite direction, on the forks **3** driving the sliding gears on the secondary shaft.

Extract the desmodromic device.

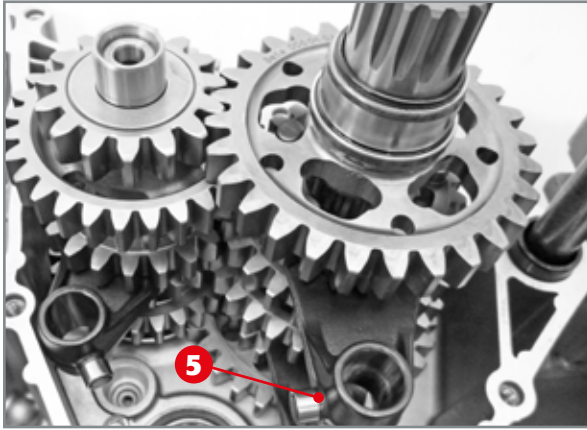

Extraction of forks from gearbox unit.

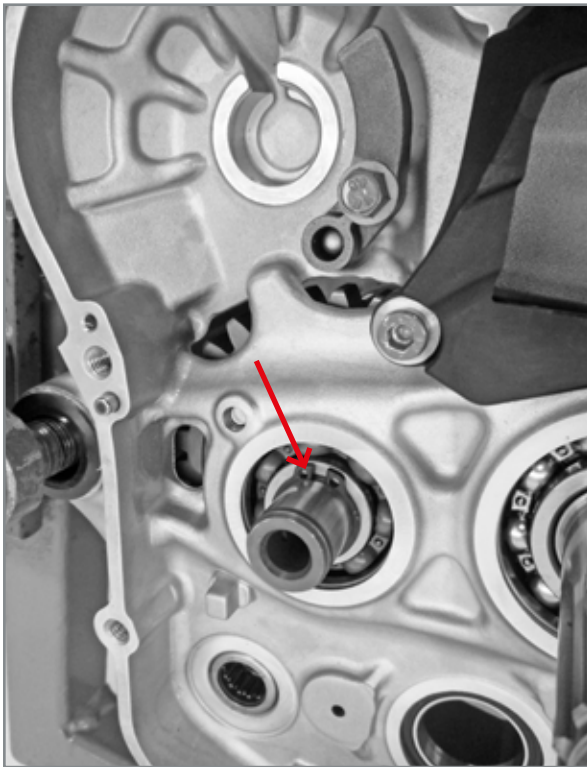

Removal of the circlip.

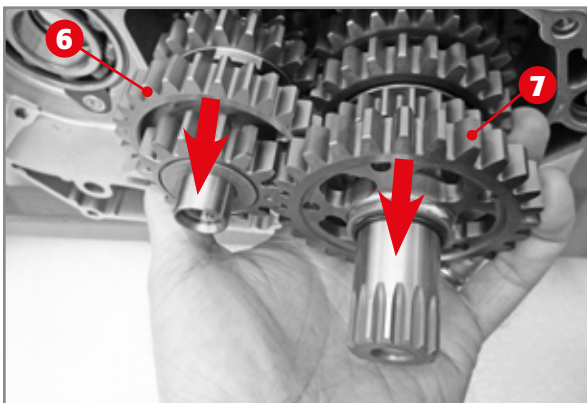

Extraction of complete gearbox unit: 6 primary unit, 7 Secondary unit.

Extract the forks together with the drive bushes 5.

ATTENTION: Make sure the circlip on the secondary shaft has been removed (par. 2.9).

Extract the whole gearbox unit consisting of primary 6 and secondary 7.

2.12 DISASSEMBLY OF PARTS FROM CRANKCASES

Once the crankcases have been detached, it is necessary to remove the various components attached to it.

The correct positioning of some bearings applied to the crankcases is ensured by locking devices such as plates or simple screws. In order to disassemble these bearings, the safety devices must be disassembled as well.

2.12.1 RIGHT CRANKCASE HALF

On the inside, the plates **1** are those which assure the correct positioning of the support bearing of the crankshaft. All you need to do is remove the two screws **2** to disassemble them.

The plate **3** is the one relating to the mainshaft support bearing of the gearbox. It can be disassembled by removing screw **4**.

The plate **5** holds the bearing of the secondary shaft of the gearbox in place. It can be disassembled by removing screw **6**.

The screws **8** hold the retaining plate **7** of the desmodromic device support bearing in place.

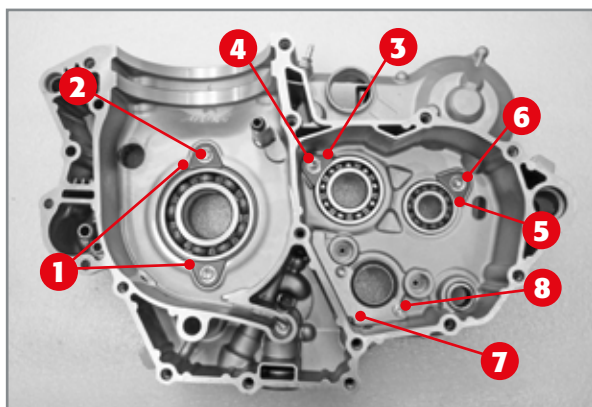

Safety devices present on the inside of the right crankcase half.

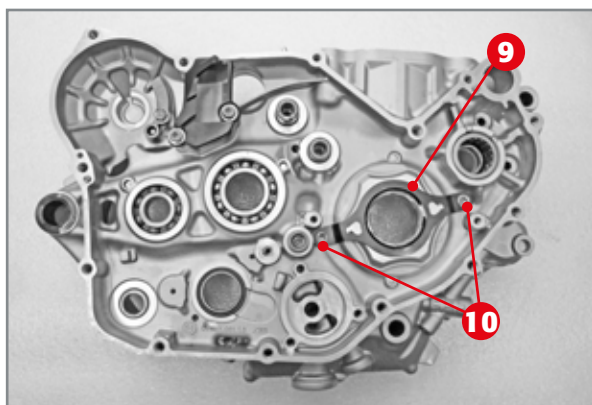

On the outside the oil seal blocking plate **9** is applied. It can be removed by taking off the two screws **10**.

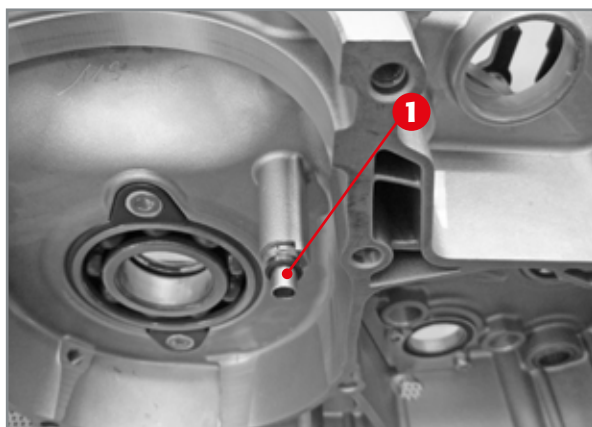

Location of piston oil jets.

2.12.1.1 Piston oil jets

It is recommended to remove the piston oil jets **1** and relative O-rings in order to check and clean the lubrication circuit.

The other oil jet is located on the left casing (par. 2.12.2).



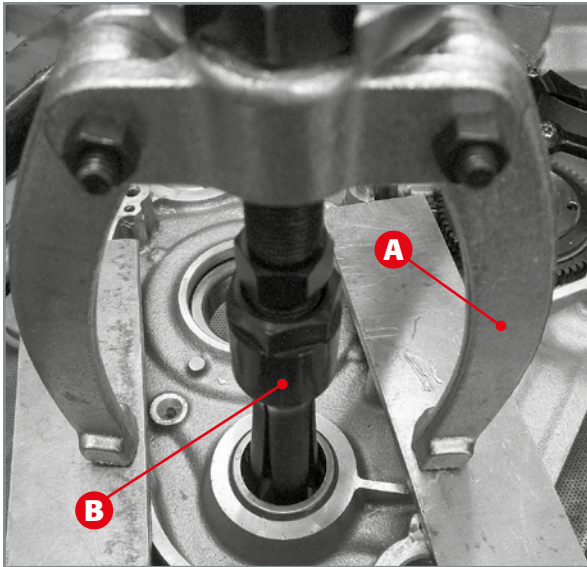

Extraction of countershaft bearing.

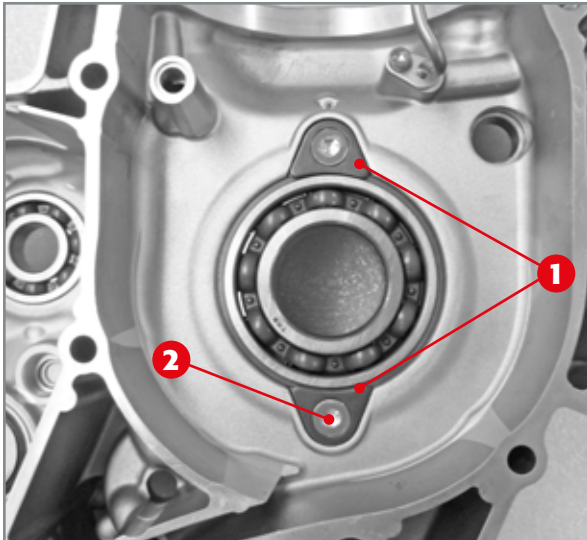

Inside safety plates of left half-casing crankshaft.

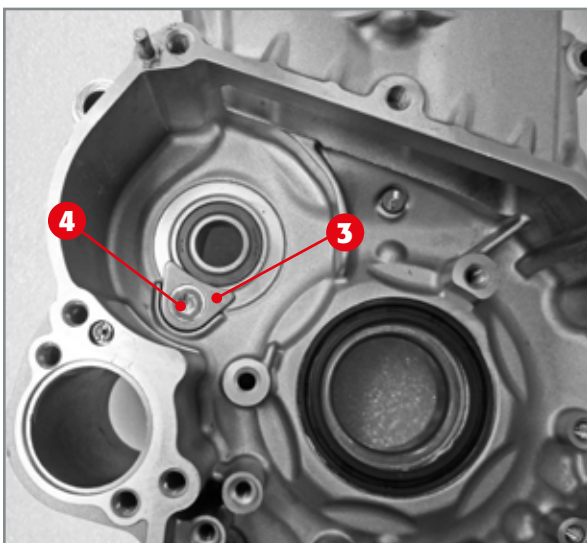

Outside safety plate of left half-casing countershaft.

2.12.1.2 Extraction of countershaft support bearing

To extract the countershaft bearing, use the extractor **A** (code 3625081) together with the extractor **B** (code 006140160000). It is recommended to apply the two aluminium plates to be placed between the legs of the extractor and the crankcase half.

2.12.2 LEFT CRANKCASE HALF

Three safety plates are present on the left crankcase half.

The plates **1** on the inside are the ones relative to the crankshaft support bearing of the gearbox. They can be disassembled by removing the two screws **2**.

The plate **3** is the one relative to the bearing which supports the countershaft. It can be disassembled by removing the screw **4**.

For checking and cleaning part of the lubrication circuit, it is advised to use compressed air in the piston **5** oil jet.

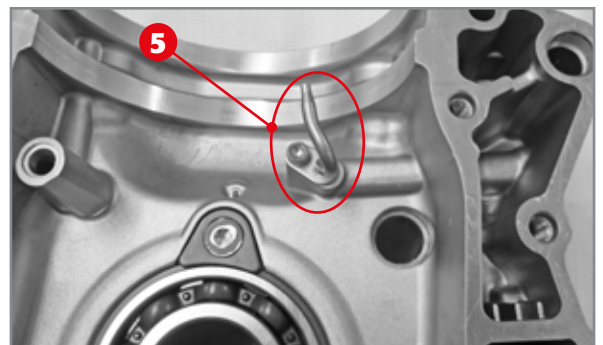

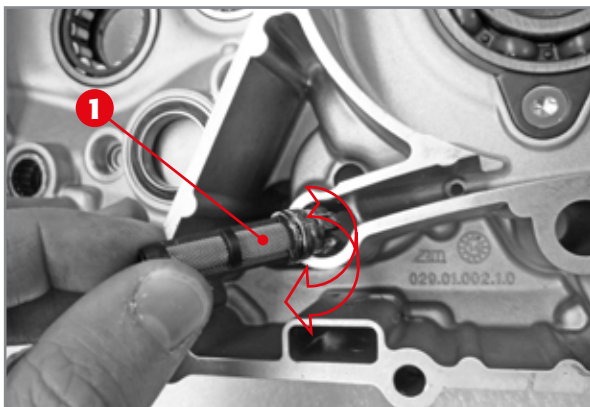

Disassembly of inner filter.

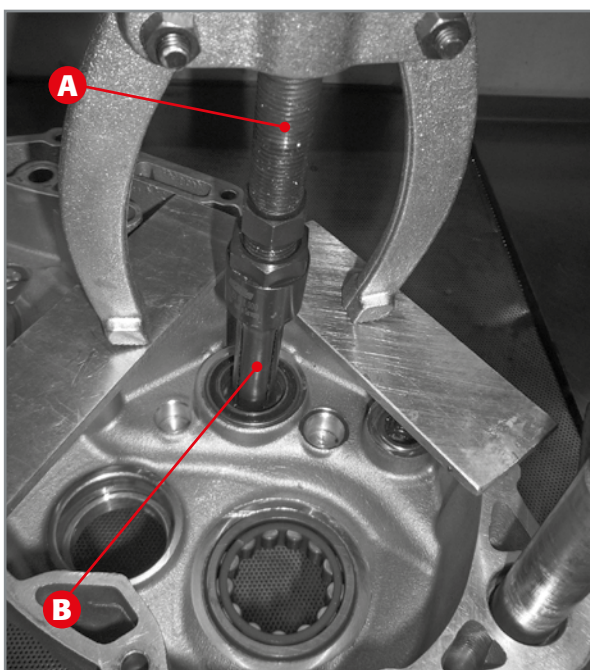

Extraction of desmodromic device bearing.

2.12.2.1 Inner oil filter

The inner oil filter **1** must be pulled out from the inside of the left crankcase. Its removal can be aided by using a soft pin to push it from the outside towards the inside, tapping with a small hammer.

2.12.2.2 Extraction of desmodromic device bearing

For the removal of the bearing dedicated to the device on the inside left crankcase half. Its removal entails use of the extractor **A** (code 3625081) together with extractor **B** (code 006140160000). Removal of bearing dedicated to the device present inside left crankcase half.

Before reassembling the engine, a series of important controls must be carried out to ensure correct functioning of the engine. The bearings must be replaced if they play or get jammed during rotation. It is however recommended to refer to the periodical maintenance table.

In order to insert the bearings in the crankcase halves, bring the crankcase halves to a temperature of 150°C and keep them at that temperature for 20 minutes.

Place the crankcase halves on a large surface where their whole seal surface can rest. When the bearings cool down, they drop into their seats on their own.



3.1 CRANKCASE HALF

The crankcase halves have some elements that need to have their integrity and use status checked. Hereafter the checks and assembly operations of the individual elements coupled to the crankcases will be described. Clean the threading and oil passages thoroughly using a degreaser and compressed air.

ATTENTION! It is absolutely necessary to replace the crankshaft oil seals present on the outside of the left and right crankcase halves. This is due to the extreme heating they undergo when being disassembled.

In general, the crankcase halves must be replaced when:

- the oil pump crankcases show scratches or meshing signs (see their location in detail; 2.11);
- once the new bearings are inserted and the crankcase half is left to cool off, they do not fit into their seats.

EXPLODED VIEW OF ENGINE CRANKCASE HALF

- 1) Complete engine crankcase;
- 4) Crankcase gasket;
- 5) Back reference bush;
- 6) Front reference bush;
- 7) Bush 17x21x19;
- 8) Inner oil filter;
- 9) O-ring;
- 15) Piston oil jet;
- 16) O-ring;
- 17) Lubrication jet;
- 18) Lubrication jet;
- 19) Centring pin;
- 20) Centring pin;
- 22) Cap;
- 23) Plate;
- 24) Screw M5x10;
- 30) Screw M5x10;
- 31) Bush;
- 32) Oil incline; Copper gasket;
- 37) Copper washer;
- 38) Oil pressure control valve screw;
- 39) Cable gland.
- 44) Oil jet;
- 46) O-ring.

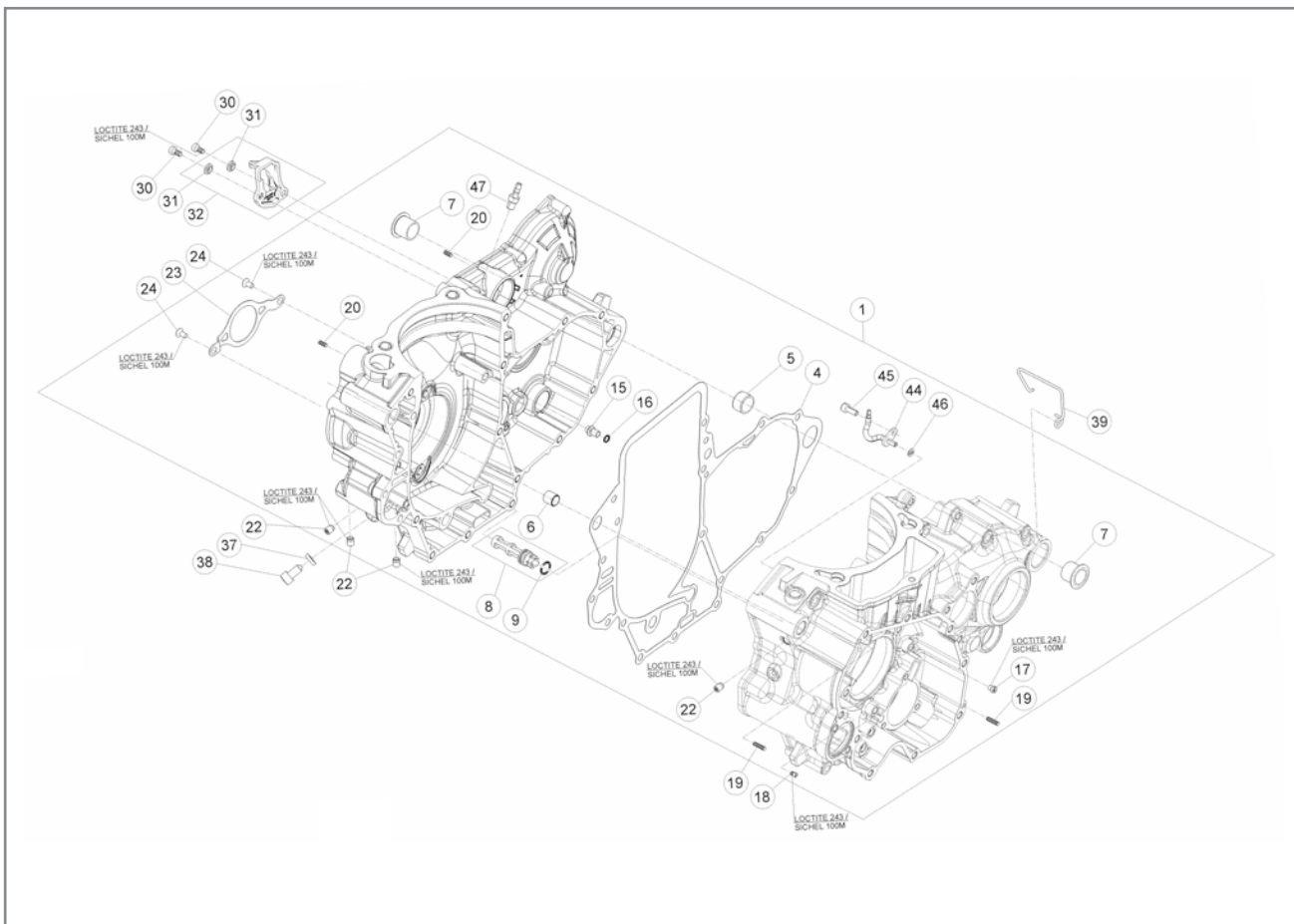

3.1.1 EXTERNAL RIGHT SIDE

Pull out the crankshaft oil seal 1 and replace it. Check that the oil seal fixing plate 2 is not bent. If so, have it replaced.

Check the integrity of the oil incline 3. Should it be worn, have it replaced.

Check the state of use of the kickstart ramp 4. It must be replaced if it shows signs of meshing or chipping.

The table below contains indications for fixing the screws of the above-mentioned elements.

Screw number	Screw dimensions		Threadlocker application	Tightening torque [Nm]
	Threading diameter [mm]	Threading length [mm]		
5	M5	10	Loctite 243/ Sichel 100M	6
6	M5	10	Loctite 243/ Sichel 100M	4
7	M6	20	Loctite 243/ Sichel 100M	10

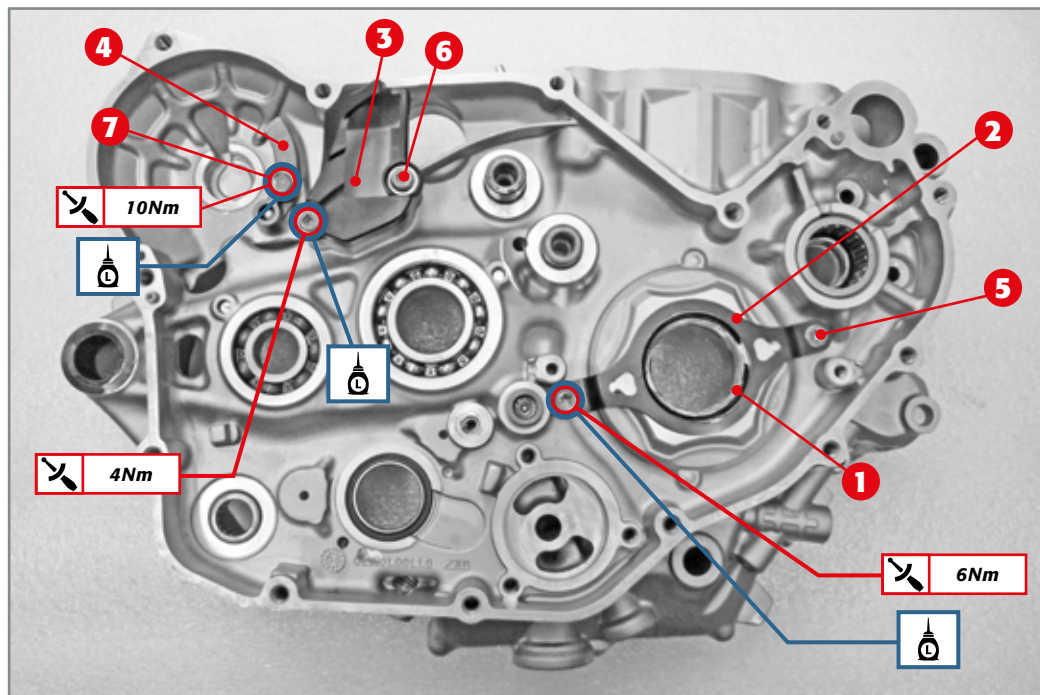

Elements present on outside right crankcase half.

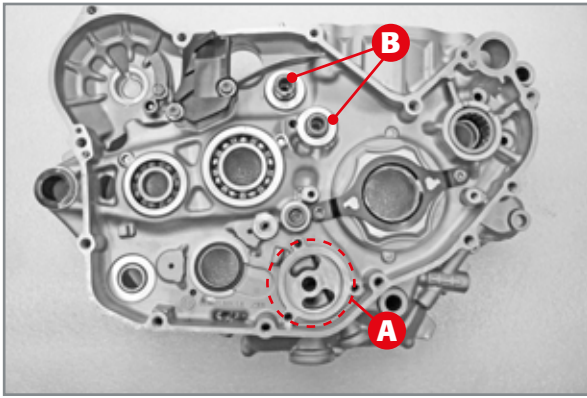

The crankcase half will definitely need to be replaced when:

- the oil pump crankcase **A** shows deep scratches or meshing signs;
- the two pins **B** for the idler wheel and torque limiter show traces of abnormal wear or meshing.

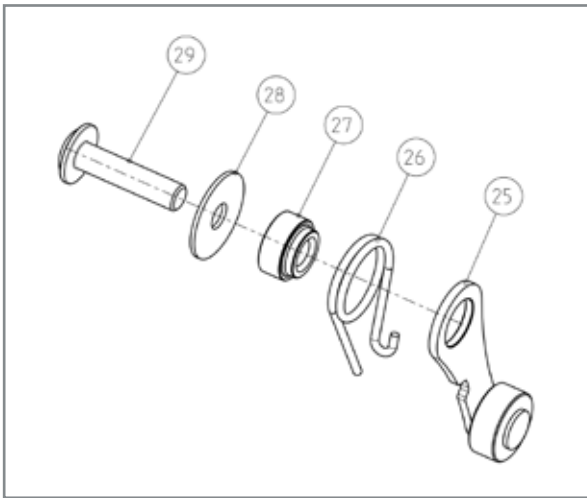

Apply the stopping device as follows.

Keeping the tightener on the lever **25** facing towards the crankcase half, apply the spacer **27** onto it, by inserting the smaller diameter segment in the lever. Apply the spring **26** so that the hook inserts into the groove present on the lever **25** and then apply the washer **28** and the screw **29** M6x20 whose threading must be spread with medium strength threadlocker.

EXPLODED VIEW OF STOPPING DEVICE

- 25) Lever;
26) Spring;
27) Spacer;
28) Washer 6x20x1;
29) Screw M6x20.

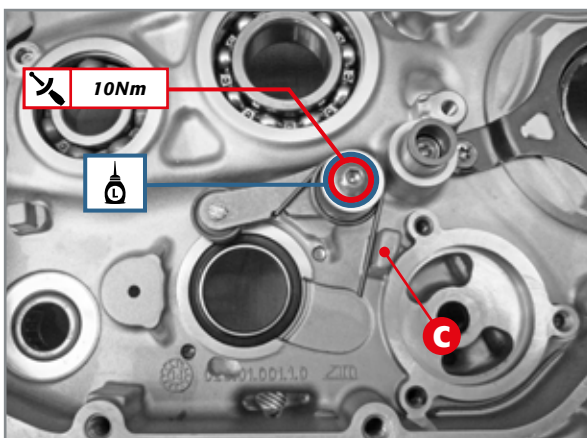

Stopping device coupled with the crankcase half.

Apply the entire device on the crankcase half so that the straight segment of the spring rests on the stop **C**. Tighten the screw to the indicated torque.

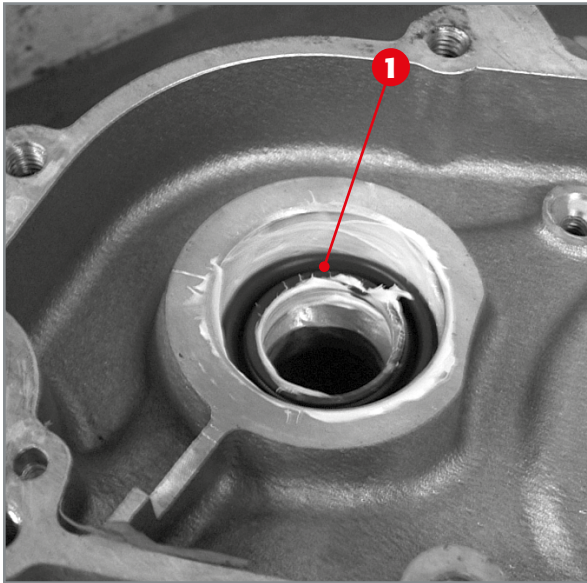

Application of oil seal 1.

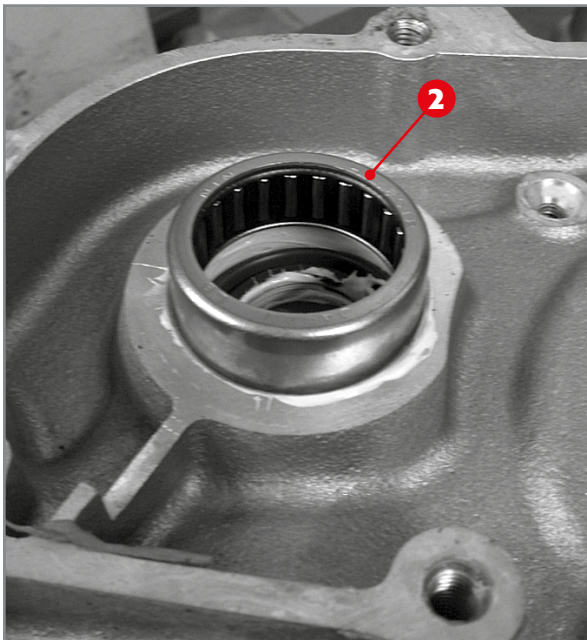

Insertion of bearing 2.

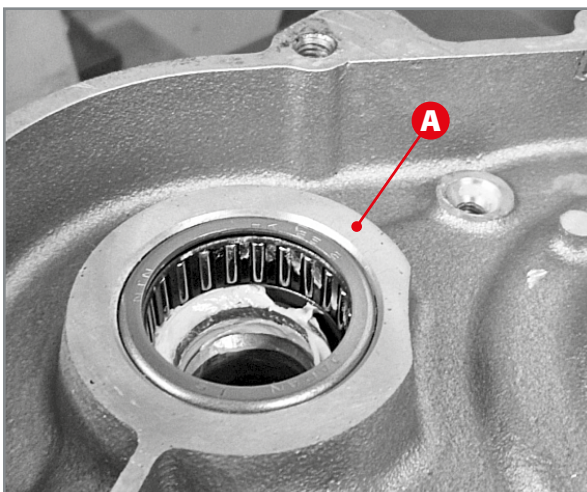

Oil seal and bearing unit coupled to the left crankcase half.

3.1.1.1 INSERTION OF OIL SEAL AND COUNTERSHAFT SUPPORT BEARING

In order to insert the oil seal and countershaft support bearing proceed as follows. Grease the oil seal and bearing housing. Insert the new oil seal 1 greasing the inside of it.

Apply the new bearing 2 paying close attention that it is aligned in its seat.

Use a press or similar instrument to push the bearing until the outside surface is flush with the surface A.

3.1.2 INTERNAL RIGHT SIDE

Check the flatness of the crankshaft bearing retaining plates **1**, of the mainshaft bearing retaining plate **2**, of the secondary shaft bearing retaining plate **3**, and of the desmodromic device bearing retaining plate **4**.

The table below carries the indications for application of the fixing screws of these plates and for fixing the desmodromic device support bearing.

Screw number	Screw dimensions		Threadlocker application	Tightening torque [Nm]
	Threading diameter [mm]	Threading length [mm]		
5	M6	12	Loctite 243/ Sichel 100M	8
6	M6	12	Loctite 243/ Sichel 100M	8
7	M6	12	Loctite 243/ Sichel 100M	8
8	M5	10	Loctite 243/ Sichel 100M	4

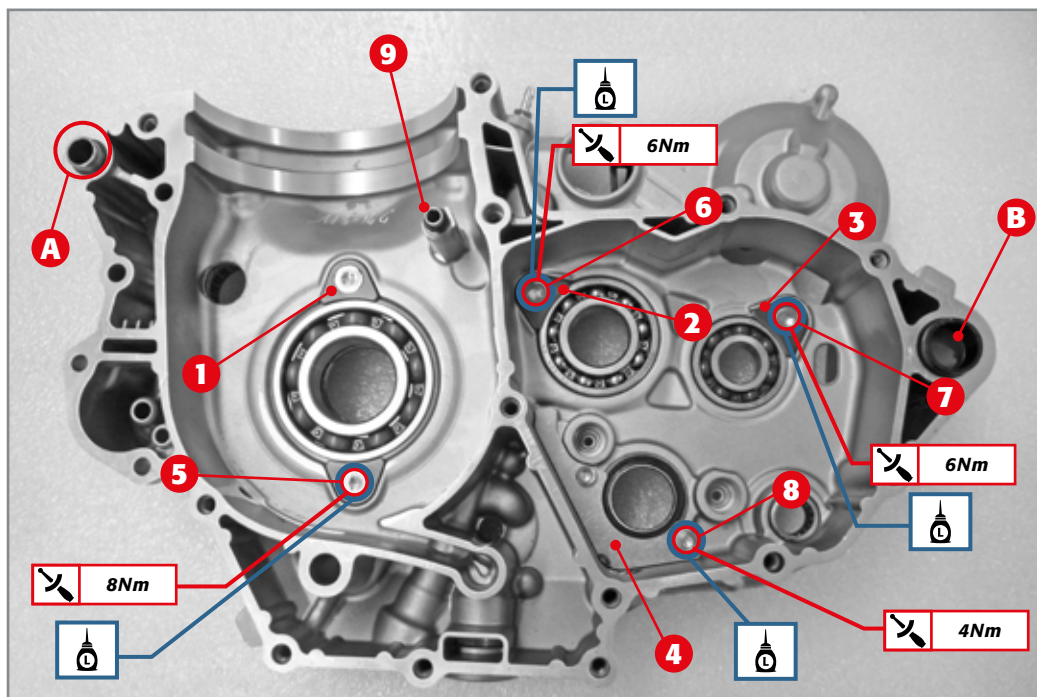

Elements present on inside right crankcase half.

Insert the two reference bushes **A** and **B** in their respective housings.

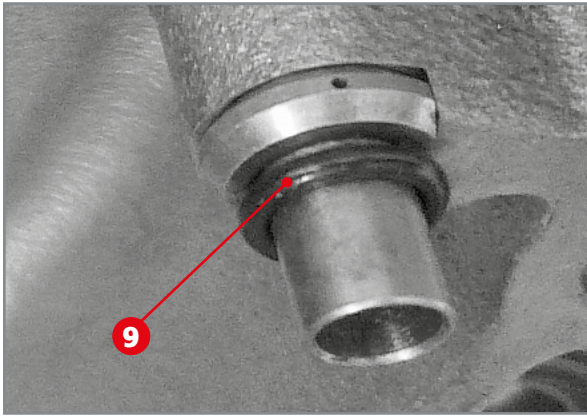

Piston oil jet O-ring and detail of passage hole.

Make sure the piston oil jets are positioned correctly and free of obstructions.

Make sure that O-ring 9 is correctly positioned by checking its state. Should the O-rings have cracks or deformations, they must be replaced.

3.1.3 EXTERNAL LEFT SIDE

Make sure the calibrated screw 1 and the jet 2 are not obstructed. Should they have been replaced, couple them to the crankcase using a small amount of medium strength threadlocker, being careful that the threadlocker does not block the holes. Then tighten them all the way.

Make sure that the oil passage A is cleaned well. Make sure that the countershaft bearing retaining plate 3 is not deformed.

If it is, replace it. The table below carries the indications for application of the screw for the plate 3.

The crankcase half will definitely have to be replaced if the oil pump crankcase B has deep scratches or signs of meshing.

Screw number	Screw dimensions		Threadlocker application	Tightening torque [Nm]
	Threading diameter [mm]	Threading length [mm]		
4	M6	12	Loctite 243/ Sichel 100M	8

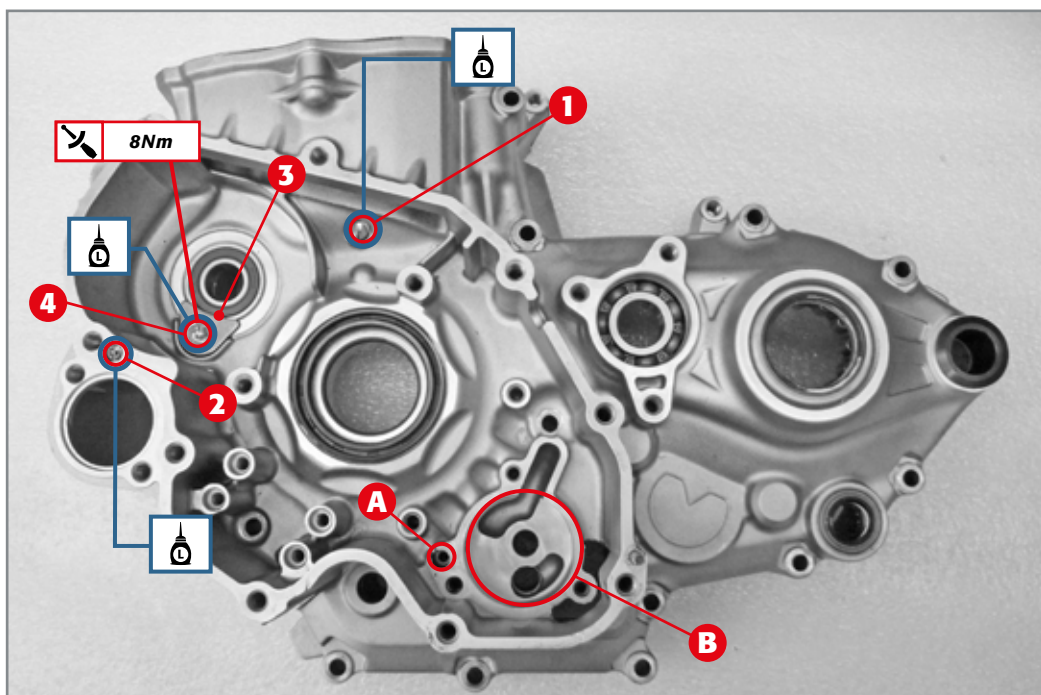

Elements present on outside left crankcase half.

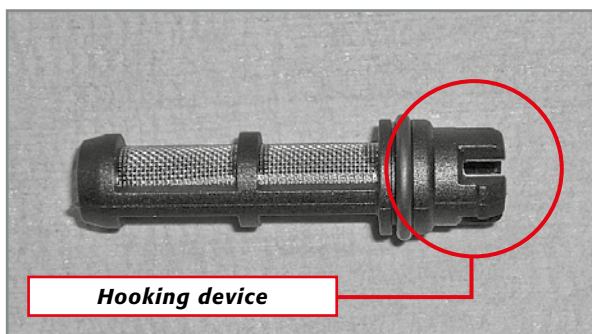

3.1.4 INTERNAL LEFT SIDE

Clean the inner filter thoroughly and check the integrity both of the wire metal and the hooking device. Should the filter be deteriorated in any of these parts, replace it.

Check the state of the two crankshaft bearing retaining plates **1**. If they are deformed, have them replaced.

The table below carries the indications for application of the screws for the plates **1**.

Insert the inner filter **3** in its seat **A** present in the crankcase and push it all the way down until you hear the hooking device click.

Apply the oil jet **4** after application of O-ring **5**. Apply screw **6** after application of medium resistance threadlockers. Tighten at the specified torque.

Screw number	Screw dimensions		Threadlocker application	Tightening torque [Nm]
	Threading diameter [mm]	Threading length [mm]		
2	M6	12	Medium strength	8
6	M4	10	Medium strength	6

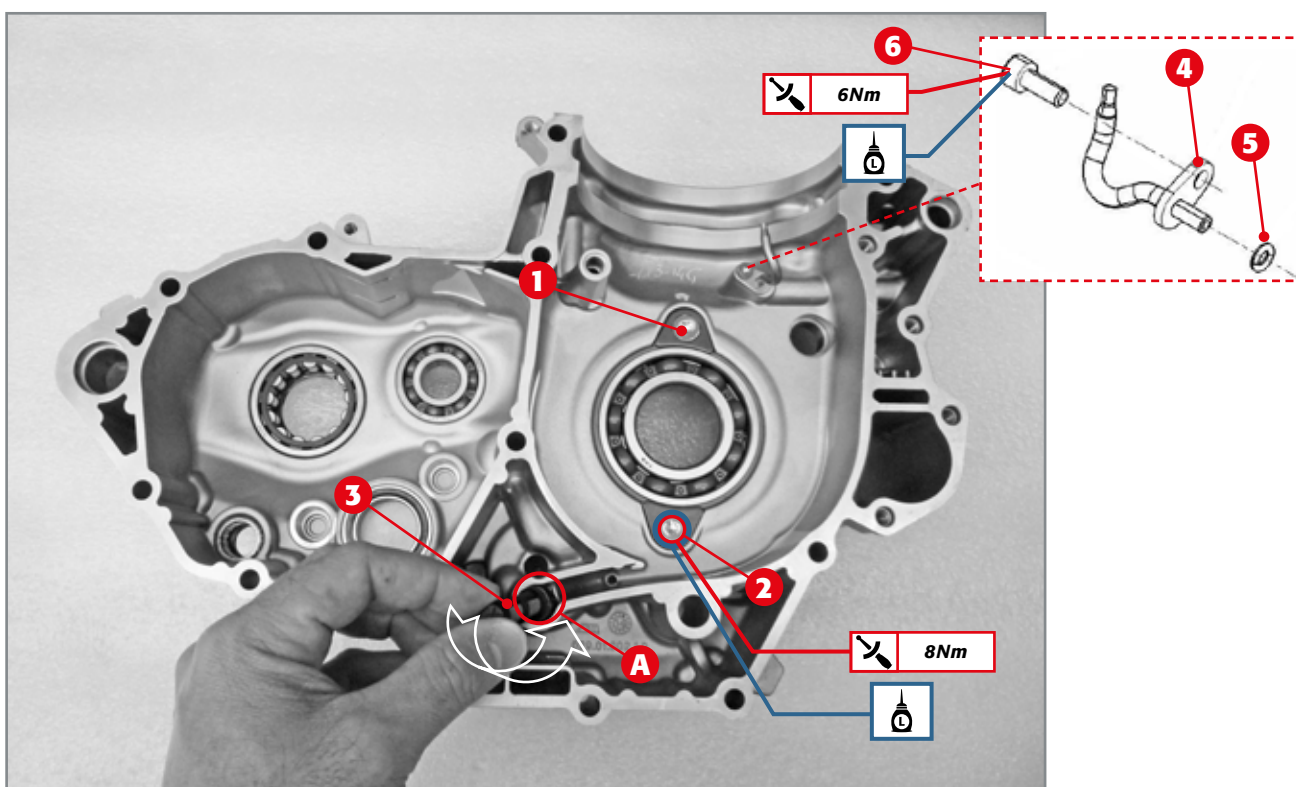

Elements present on inside left crankcase half.



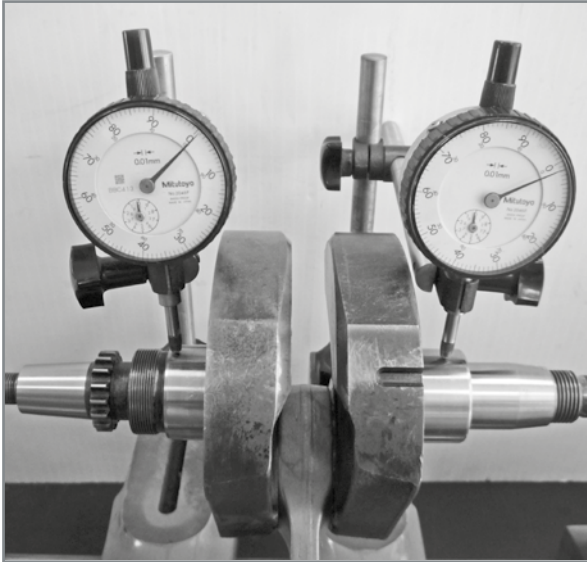

Deflection/Off-centring of crankshaft.

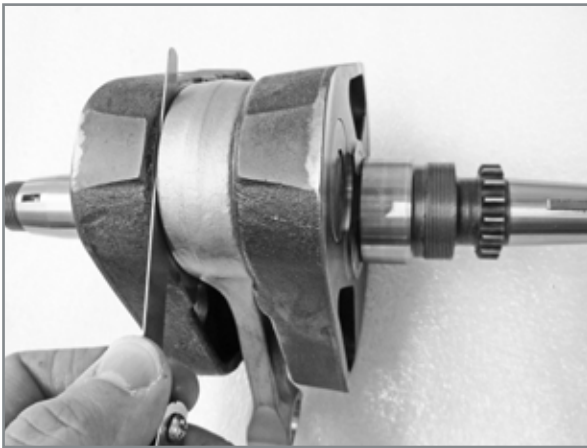

Connecting rod axial play.



Connecting rod radial play.

3.2 CHECKING THE CONNECTING ROD AND MOTOR SHAFT

After having checked the state of wear of the coupling surfaces, check the offset of the half shaft axes by placing the crankshaft in between two tailstocks or similar instrument. Control the maximum measurement variation during a complete turn, using comparators positioned on the coupling surfaces with the crankshaft bearings.

Allowed limit value: 0.03 mm

Check the axial play between the connecting rod head and the half shafts.

**Recommended play:
0.42÷0.65mm**

Check the radial play of the connecting rod head bearing by placing the crankshaft on a stable support. Then position a comparator in axis with the connecting rod, and pressing lightly in the direction of the crank lever axis, check that the measurement detected does not exceed the service limit.

Maximum play: 0.04mm

If play is greater, replace the connecting rod.

Make sure that the chain control gear is free of chipping or signs of abnormal wear. Replace the crankshaft should it be deteriorated.

The distance between the two opposite sides of the half shafts must be :

64mm±0.05 (350cc, 390cc)

65mm±0.05 (430cc, 480cc)

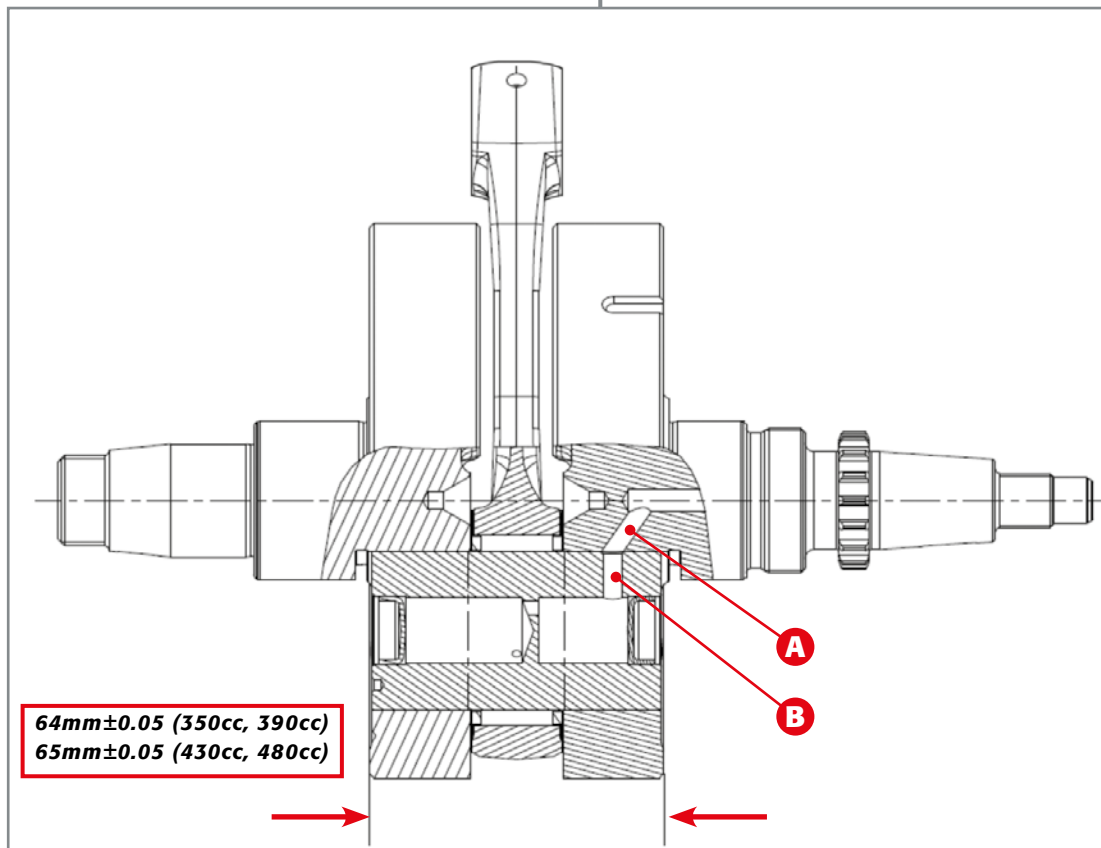

Crankshaft oil passages.

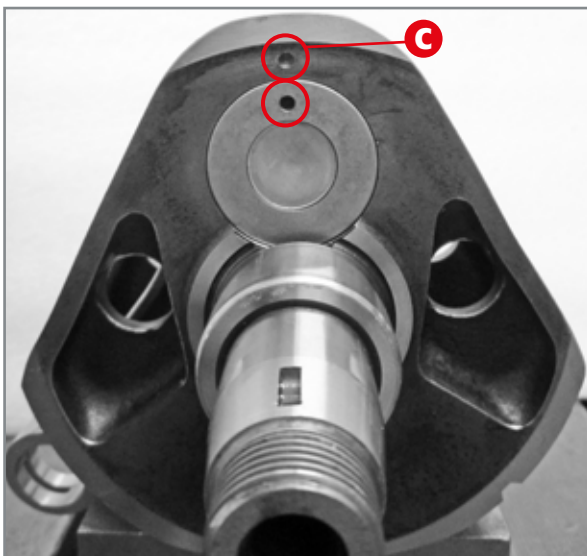

Half shaft and crank lever pin bolt references C.

If the two half shafts are detached for replacement of the connecting rod, pay close attention when repositioning the crank lever respect to the half shafts. The holes for oil passage **A** on the half shaft must coincide with those present on the crank lever **B**.

Incorrect positioning would cause an irregular oil flow rate thus damaging the connecting rod head bearing.

The references **C** which must be aligned are found on the half shaft on the flywheel side and on the crank lever of the pin bolt.



Bore meter verification of inside diameter of connecting rod foot.

Use a bore meter to check the inside diameter of the connecting rod foot which must not exceed the following service limit:

**service limit 18.04mm (350cc, 390cc)
19.04mm (430cc, 480cc)**

Remember that the measurement must be made placing the axis of the feeler in parallel with the axis of the connecting rod.

3.3 COMPLETE CRANKSHAFT ASSEMBLY

When all the aforementioned controls have been carried out and the worn parts replaced, grease the crankshaft oil seal on the right crankcase half and couple the crankshaft to the left crankcase half. Keep the gear present on the crankshaft towards the left. In order to carry out this operation, you must just push the shaft axially towards the crankcase.

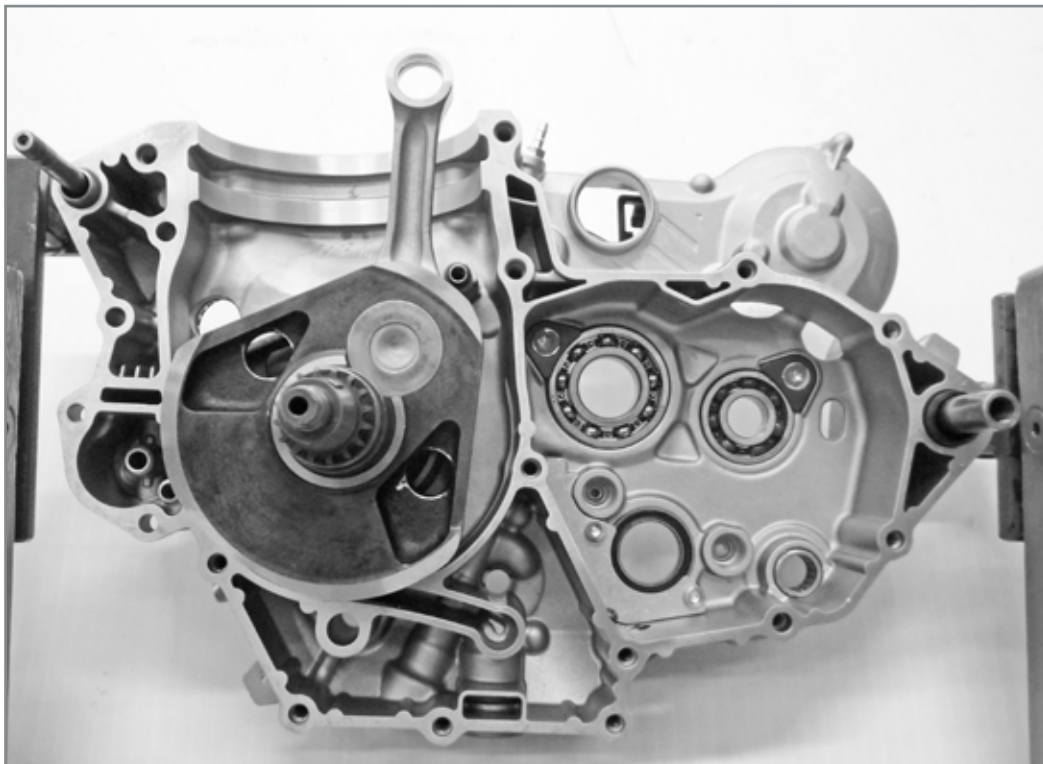

Insertion of crankshaft in the right crankcase: note the position of the gear.

3.4 GEARBOX UNIT: CONTROLS AND REASSEMBLY

The gearbox unit is made up of the gearshift and of the gearbox itself. The gearshift is then divided into external and internal gearshift. The following are the verifications and procedures for checking and reassembling these units to the engine.

3.4.1 GEARBOX UNIT CHECK

Use protective jaws to clamp the mainshaft and secondary shaft.

Use a thickness gauge to check the axial play between the gearshift forks and the gearwheels. The play detected must not exceed the service limit indicated below:

service limit: 0.5mm

If the detected axial play is greater, before replacing either the gearwheels or the forks, check their state of wear (par. 2.4.4).

Remove the various elements and check that:

- the support surfaces of the mainshaft and secondary shaft are free of abnormal wear or signs of seizure;
- the sides of the teeth are free from chipping or abnormal wear;
- the sliding areas of the gearwheels are free from abnormal wear or traces of seizure;
- the front claw clutches of the gearwheels are not chipped or rounded;
- the roller bearings are intact and efficient;
- none of the thrust washers show traces of abnormal wear or meshing.

Should any of these defects present themselves, replace the concerned parts.

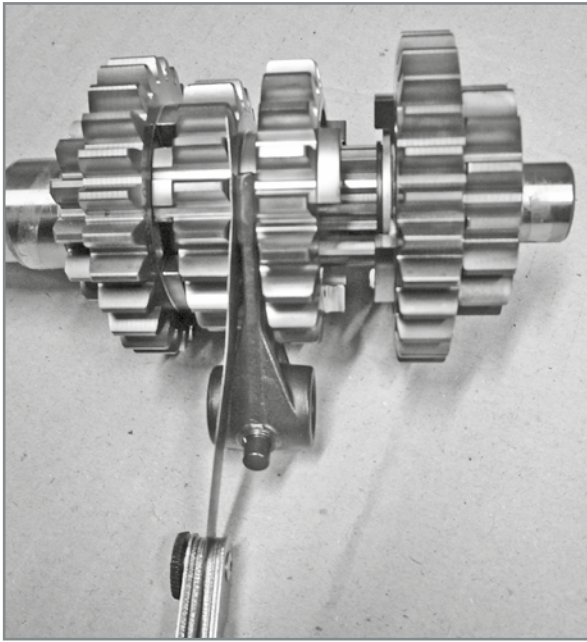

Check of wear of forks and gearwheels.

3.4.2 PRIMARY UNIT ASSEMBLY

Before proceeding with reassembly, clean all the elements thoroughly and oil them with gear oil. Always replace the circlips.

Clamp the mainshaft **1** (using protective jaws), so that the grooved end faces downwards.

Insert onto the lower cylinder part of the shaft: the roller cage **2**, the 5th gear **3** turning the front claw clutches upwards, the 26x32x1.5 thrust washer **4** and the circlip **5**.

Insert the III – IV sliding gear (**6**) so that the smaller gear faces downwards, and then insert the circlip **5**. Insert the 23x32x1.5 thrust washer **7**, the roller cage **2**, the 6th gear **8** with the front claw clutch facing downwards, the 2nd gear **9** with the cavity facing upwards and finally the 17x30x1 thrust washer **10**.

EXPLODED VIEW OF PRIMARY UNIT:

- 1) Mainshaft;
- 2) Roller cage 22x26x13;
- 3) Fifth on primary;
- 4) Thrust washer;
- 5) Seeger sw15;
- 6) Third and fourth on primary;
- 7) Thrust washer;
- 8) Sixth on primary;
- 9) Second on primary;
- 10) Thrust washer 17x30x1

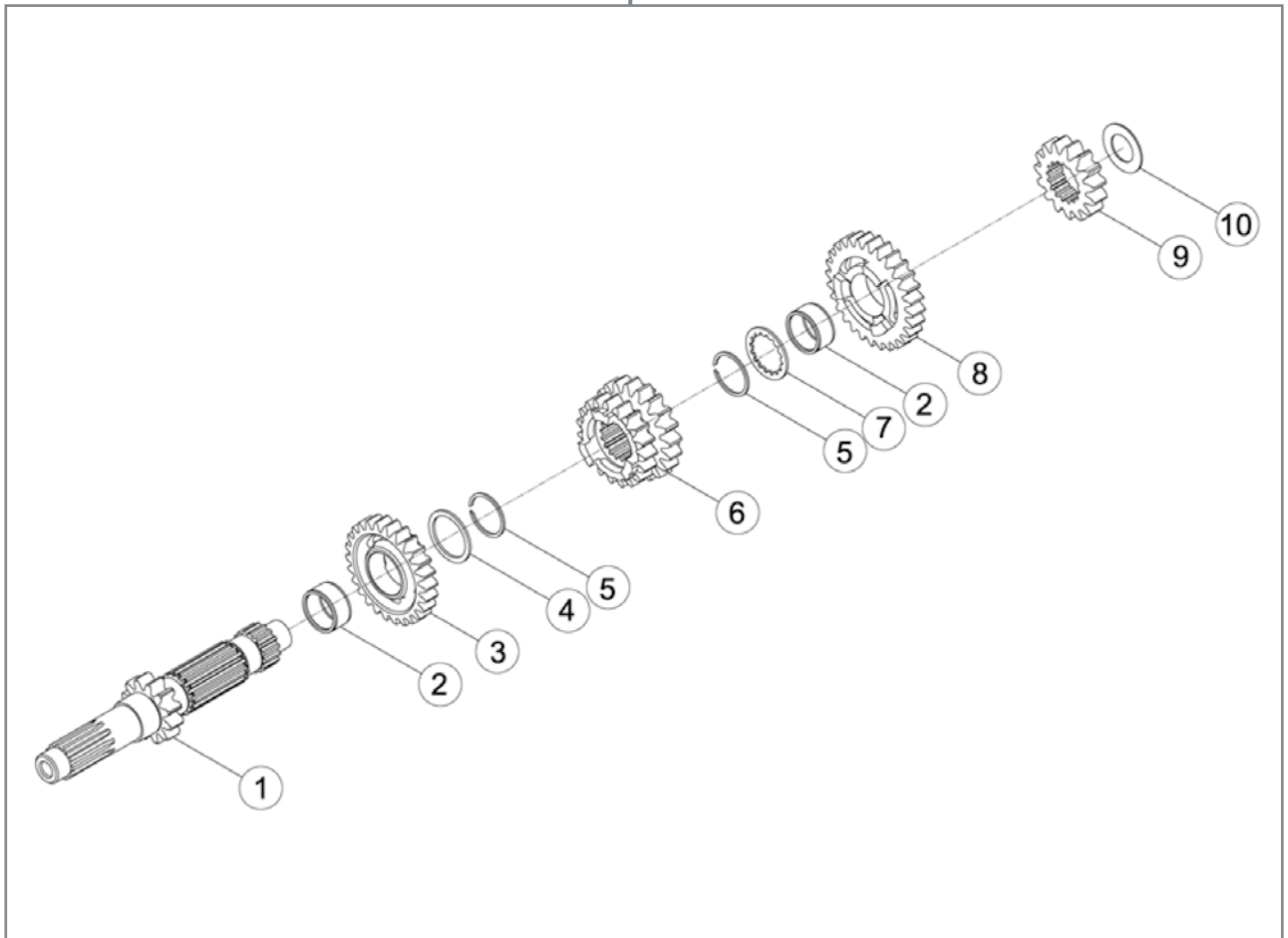

3.4.3 SECONDARY UNIT ASSEMBLY

Before proceeding with reassembly, clean all the elements thoroughly and oil them with gear oil. Always replace the circlips.

Clamp the secondary shaft **20** (using protective jaws), so that the grooved end faces downwards.

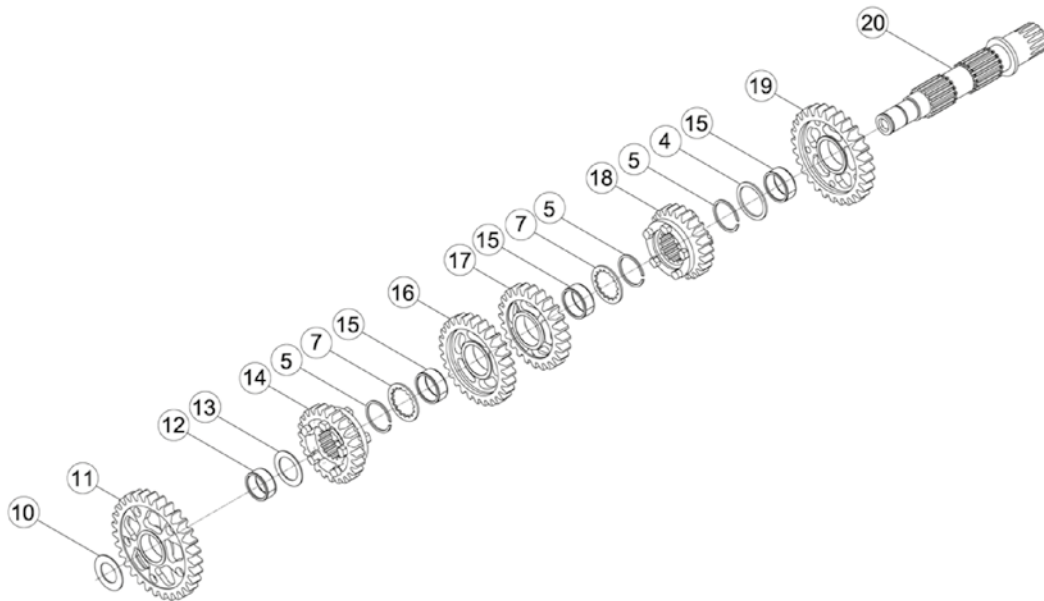

EXPLODED VIEW OF SECONDARY UNIT:

- 4) Thrust washer;
- 5) Seeger sw15;
- 7) Thrust washer;
- 10) Thrust washer 17x30x1;
- 11) First on secondary;
- 12) Roller cage 20x24x10;
- 13) Thrust washer 20x30x1;
- 14) Fifth on secondary;
- 15) Roller cage;
- 16) Third on secondary;
- 17) Fourth on secondary;
- 18) Sixth on secondary;
- 19) Second on secondary;
- 20) Secondary shaft

Insert onto the lower cylinder part: the roller cage **15**, the 2nd gear **19** so that the front claw clutches face downwards, the 26x32x1.5 thrust washer **4** and the circlip **5**.

Insert the 6th gear **18** so that the fork seat faces upwards and the circlip **5**.

Insert the 23x32x1.5 thrust washer **7**, the two roller cages **15**, the 4th gear **17** with the front claw clutches facing upwards, the 3rd gear **16** with the front claw clutches facing downwards, the 23x32x1.5 thrust washer **7** and the circlip **5**. Insert the 5th gear (**14**) with the fork seat facing downwards, the thrust washer **13** (20x30x1), the roller cage **12**, the 1st gear (**11**) with the front claw clutches facing upwards and finally the thrust washer **10** (17x30x1)

3.4.4 CHECKING THE FORKS, FORK PINS AND DESMOTROMIC DEVICE

The internal gearshift is made up of:

- two forks **13** which drive two gears on the secondary unit;
- one fork **14** which drives one gear on the primary unit;
- three drive pin bushes **15**;
- two fork pins **16**;
- desmodromic gearshift **18** through whose rotation the forks are driven thus selecting the desired gear.

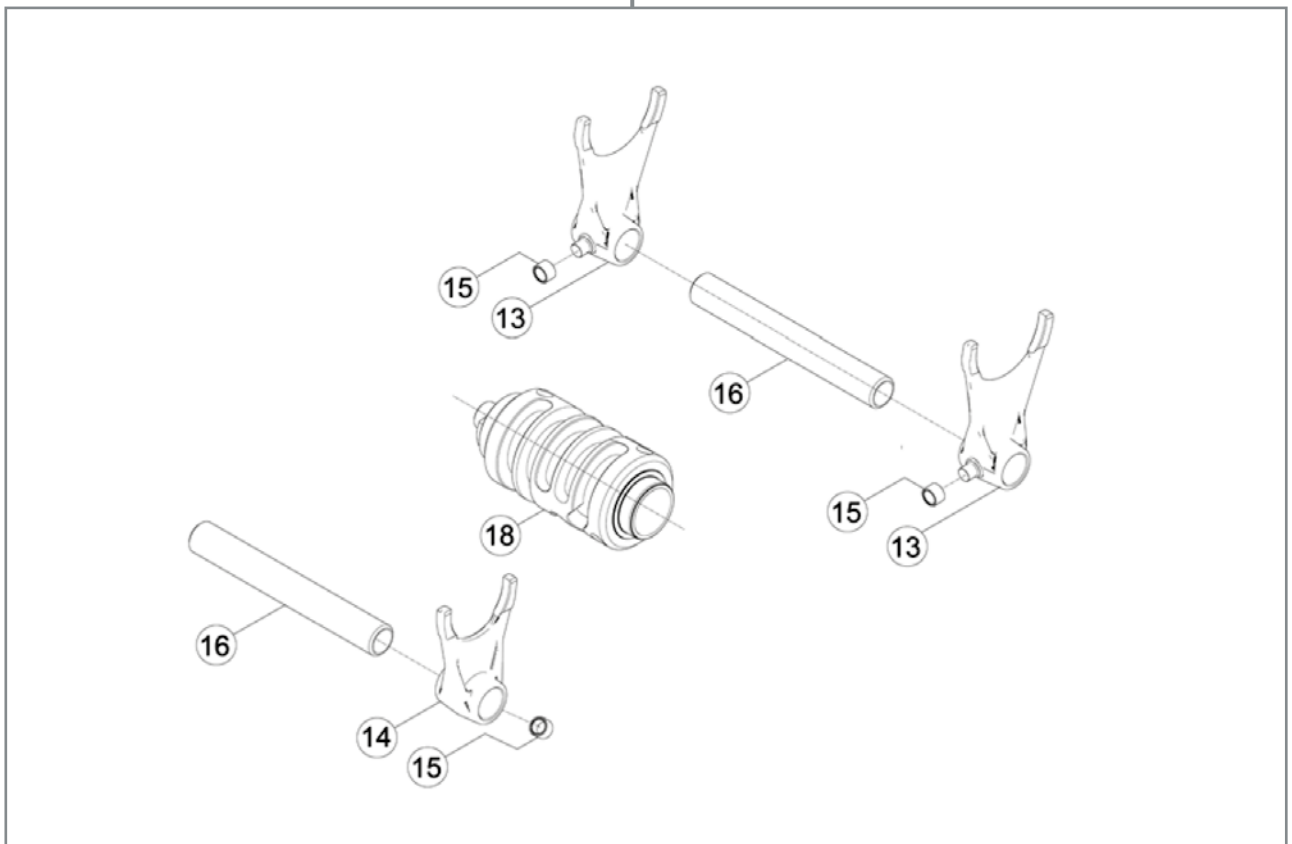

EXPLODED VIEW OF INTERNAL GEARBOX CONTROL UNIT:

- 13) I - IV fork;
- 14) V - VI fork;
- 15) bush;
- 16) fork pin;
- 18) desmodromic control

Check to make sure that the drive pins which support the bushes **15** have no traces of meshing or abnormal wear and that the bushes themselves are not worn.

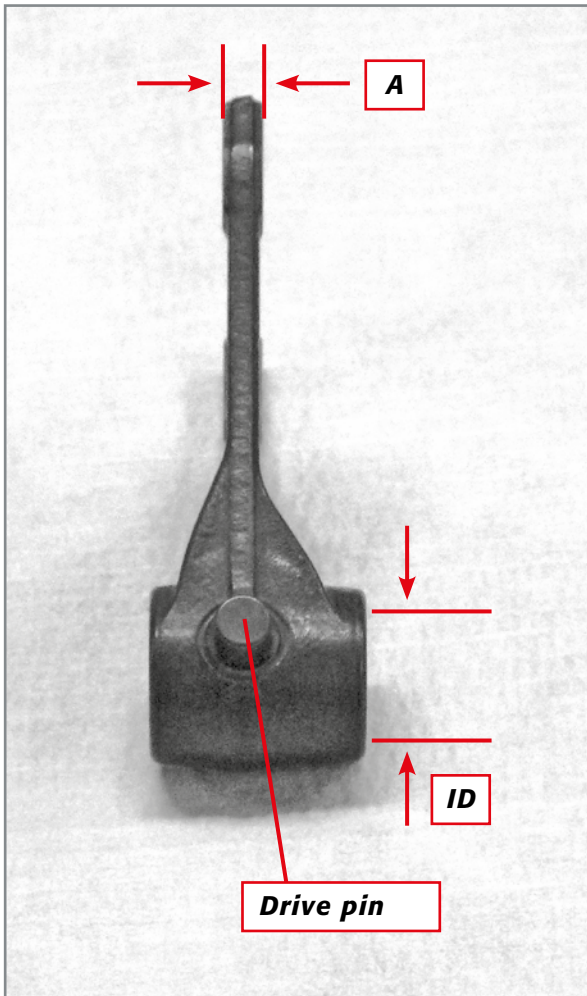

Make sure the distance **A** between the outer faces of the fork is not less than that indicated below:

Minimum acceptable distance: 4.25mm

Check to make sure that the inside diameter **D** of the fork pin seats is below the limit:

Fork inside diameter limit: 13.83mm

Make sure that the fork pins upon which they slide have an outside diameter above the limit (to be measured in the sliding areas of the forks and in the housing areas of the crankcases):

Fork pin outside diameter limit: 13.75mm

Make sure that the desmodromic control device has no corroded or worn areas especially in the grooves in which the drive pins of the forks are engaged.

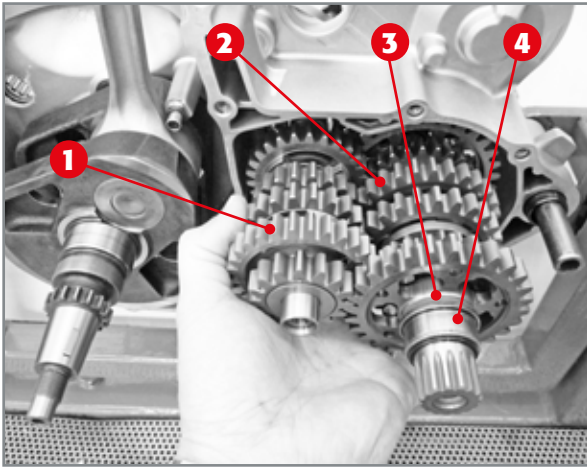

Insertion of gearbox in left crankcase.

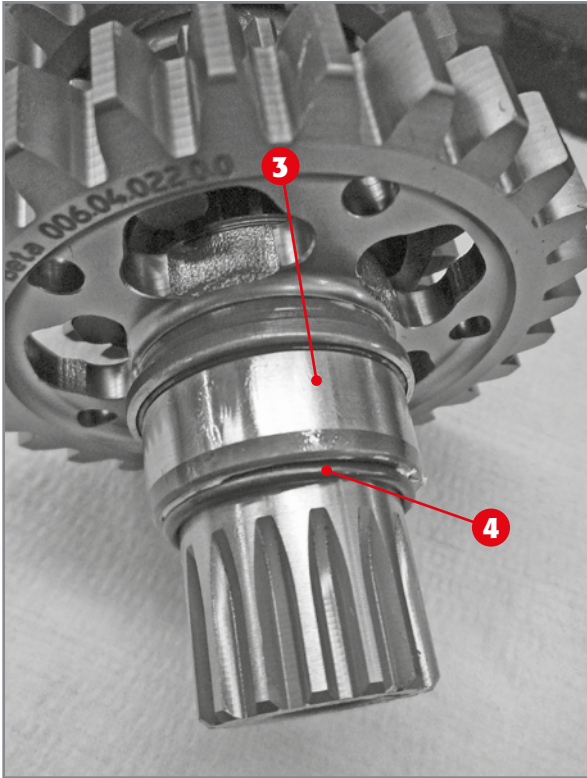

Detail of centre bearing 3 and O-ring 4 coupled to the secondary shaft.

3.5 GEARBOX AND INTERNAL GEARSHIFT ASSEMBLY

Insert the entire primary 1 and secondary unit 2 into the respective seats on the left crankcase half simultaneously. Remember to oil the gears abundantly with gear oil and to grease the shafts supporting them in the areas where they are coupled with the bearing with graphitic grease. Make sure that all the parts slide properly.

Insert the centre bearing 3 and the O-ring 4 on the secondary unit.

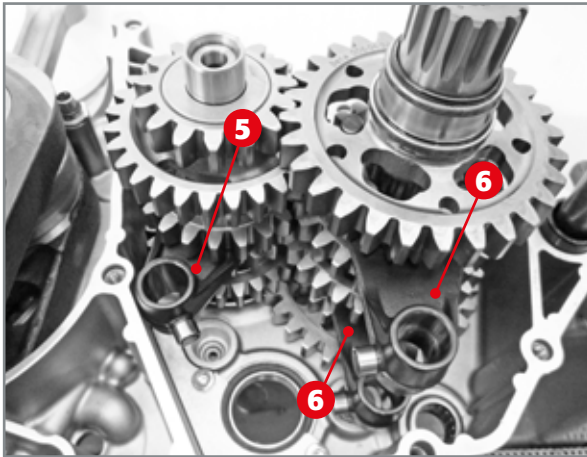

Application of forks to gearwheels.

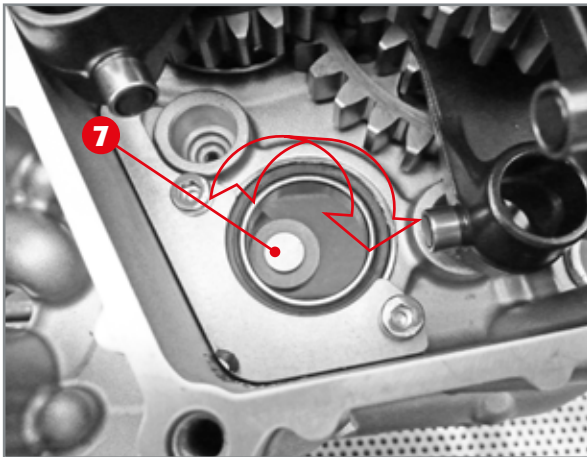

Insertion of desmodromic device in specific bearing. Note the rotation of the stop lever.

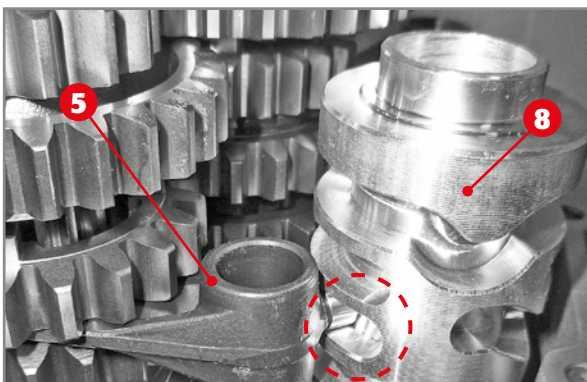

Place fork 5 of the primary unit in the central guide of desmodromic device 8.

Introduce the forks together with the drive bushes on the gear tracks. To be precise; the smaller fork **5** drives the sliding gear on the primary unit, while the other two (**6**) drive the sliding gears on the secondary unit.

Note: the two forks **6** are interchangeable and their positioning is univocal, since the drive pin must face the desmodromic device. Place the forks in their original positions if none of the components are replaced.

Insert the desmodromic device in the specific bearing. In order to do this, it is necessary to rotate cam stop lever **7** towards the bottom part of the engine.

Position the fork **5** of the primary unit in the central guide of the desmodromic device **8**, insert the fork pin inside the fork itself and insert the pin in its proper seat in the crankcase half.

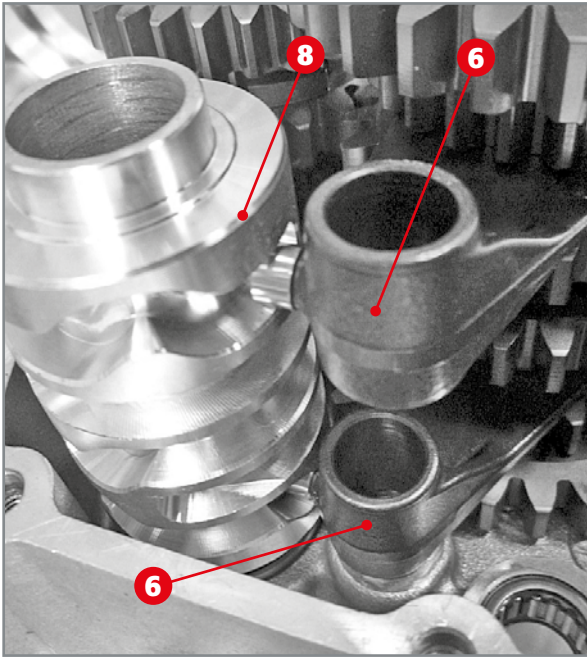

Positioning of the secondary unit forks 6. In the external guides of desmodromic device 8.

Position the two forks 6 of the secondary unit in the external guides of the desmodromic device 8 and, just like the primary unit fork, insert the fork pin first in the pins and then in its proper seat. Remember to oil the shafts, forks and the desmodromic device abundantly with gear oil.

Position the new crankcase gasket.

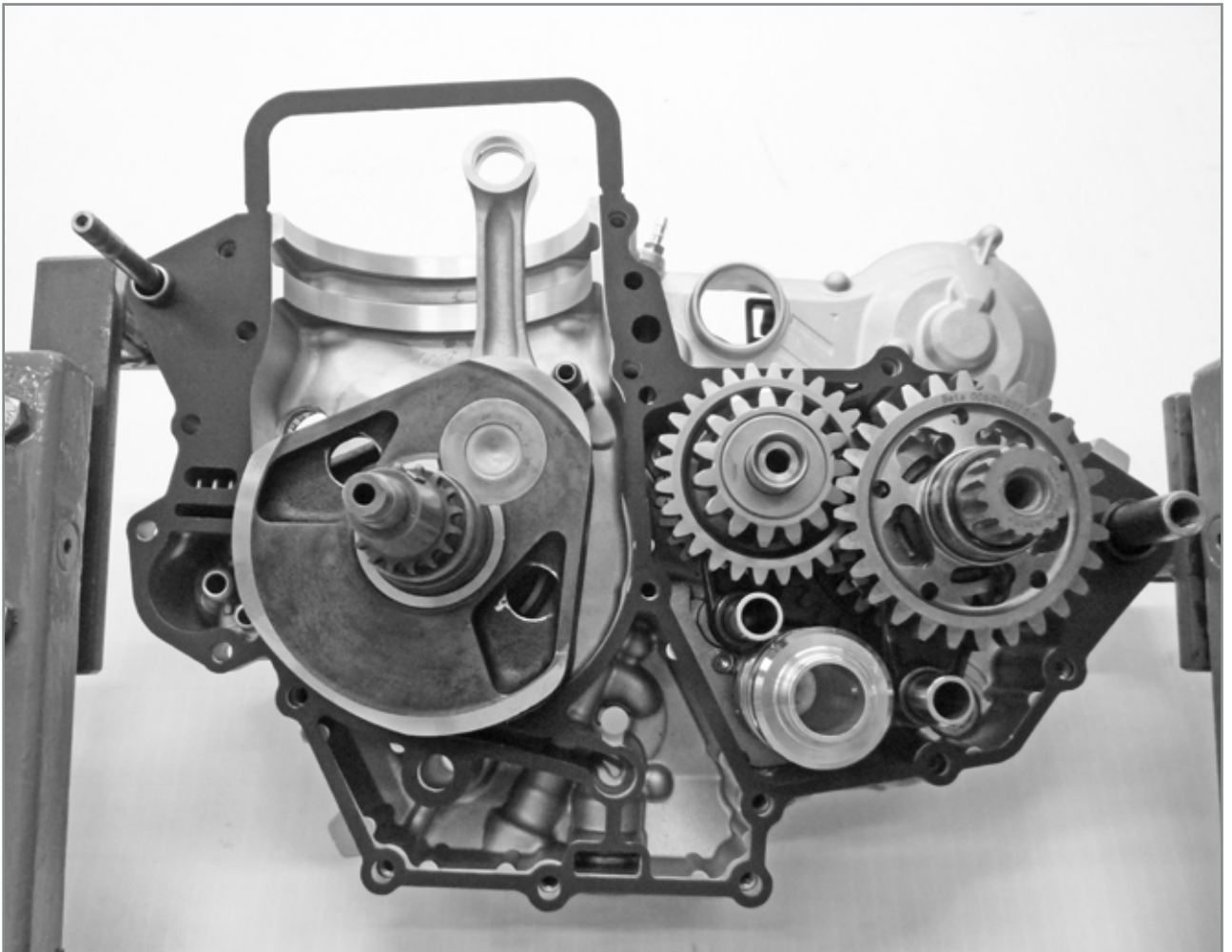

View inside the right crankcase with crankshaft, oil jets, gearbox shafts complete with gearwheels, internal gearshift and gasket.

3.6 CLOSING THE ENGINE CRANKCASE

Press the right crankcase half towards the left, being careful that the shafts and pins on the crankcase fit into the respective housings and that the crankcase half is not upside-down. To facilitate progressive nearing and aligning of the two crankcase halves, connect two screws on opposite sides and tighten them bit by bit. If the crankcase halves tend to capsize, do not insist tightening them. Rather loosen the screws and reposition the crankcase correctly.

Make sure that the two crankcase halves match perfectly one with the other. Assemble the screws according to their length as indicated in the figure.

The table below contains indications for applying these screws.

It is recommended to tighten them in a criss-cross pattern using a torque of 10Nm.

Apply the two screws for fixing the engine to the engine support (code 3625132 000)

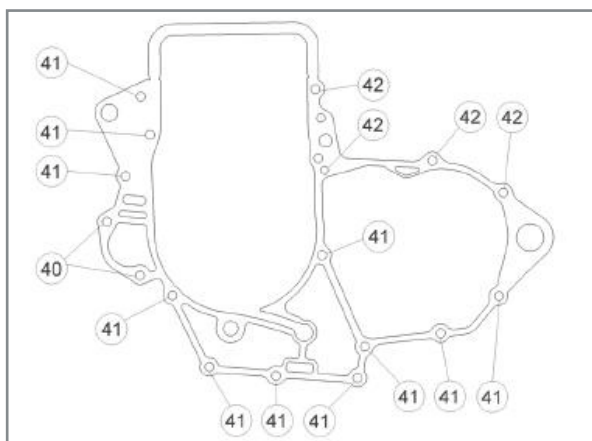

Positioning of screws to couple crankcase.

Screw number	Screw dimensions		Threadlocker application	Tightening torque [Nm]
	Threading diameter [mm]	Threading length [mm]		
40	M6	30	NO	10
41	M6	60	NO	10
42	M6	70	NO	10



Cutting extra piece of gasket between engine crankcase halves.

Cut the extra piece of gasket in between the two crankcase halves in the area of the cylinder. This can be done easily by bending the gasket several times.



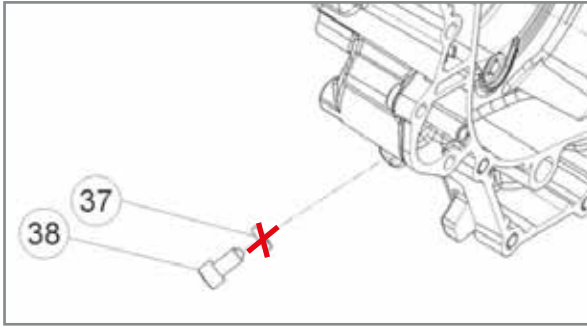

To block the crankshaft, apply only the screw 38 to the crankcase.

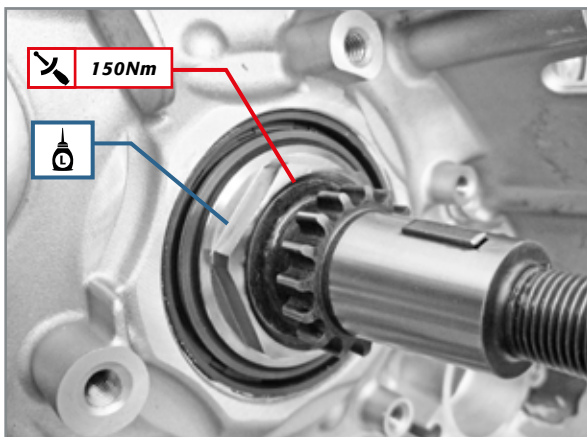

Nut on left side of crankshaft.

3.7 BLOCKING THE CRANKSHAFT AT THE TOP DEAD CENTRE AND TIGHTENING THE NUT ON THE LEFT SIDE OF THE CRANKSHAFT

To block the crankshaft in the Top Dead Centre, insert the special conical-end screw 38, without applying the washer 37 or the special engine locking tool code 006140110000, in its seat on the right crankcase half. Spread the threading on the left-hand side of the crankshaft with medium strength threadlocker.

Cover the threading on the left-hand side of the crankshaft with medium strength threadlocker. Tighten the nut using the special socket wrench A (code 006140020000) to the indicated torque.

3.8 EXTERNAL GEARSHIFT

Before reassembling the external gearshift, check its state of use. While for the stop cam it is enough to make sure it's free from abnormal wear or meshing, the gearshift drive shaft needs more in-depth inspections.

3.8.1 CHECKING THE COMPLETE DRIVE SHAFT

With the device complete, make sure that the distance between the movable pawl and the drive shaft is between **0.35÷0.80mm**. Should the distance be greater, replace the movable pawl.

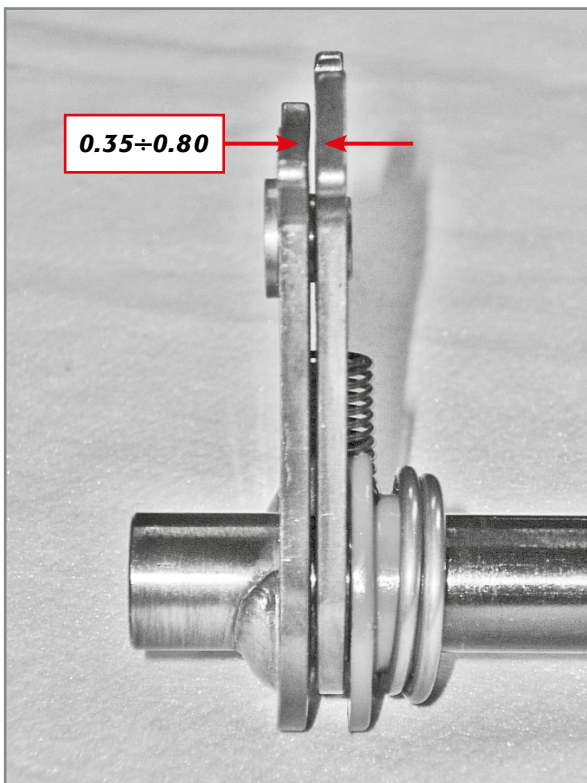

Allowed distance between shaft and pawl.

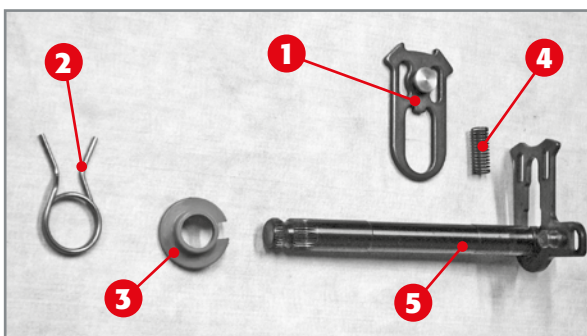

Complete drive shaft: 1) Movable pawl; 2) Gearshift return spring; 3) Spring guide; 4) Spring; 5) Gearshift drive shaft.

In order to replace the movable pawl 1, disassemble the return spring of the gearshift 2, the spring guide 3, the spring 4 (which must be compressed and pulled out of its seat) and the pawl, moving it completely towards the shaft 5.

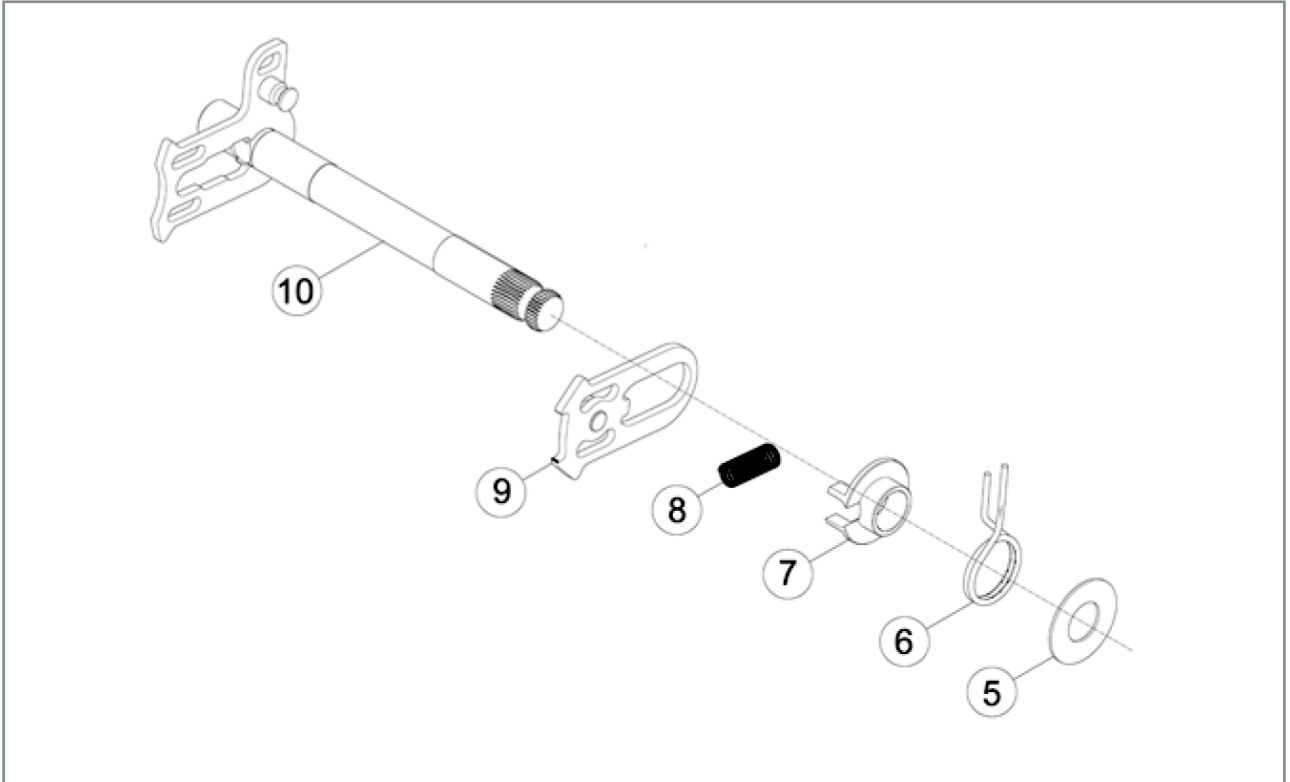

Exploded view of gearshift.

- 5) Thrust washer 14x30x1;
- 6) Gearshift return spring;
- 7) Spring guide;
- 8) Pawl return spring;
- 9) Movable pawl;
- 10) Gearshift shaft.

For reassembly, couple the movable pawl **9** to the drive shaft **10** and, while compressing it, insert the spring **8** between the movable pawl and the drive shaft. Then apply the spring guide **7**, the gearshift return spring **6** and finally the 14x30x1 thrust washer **5**.

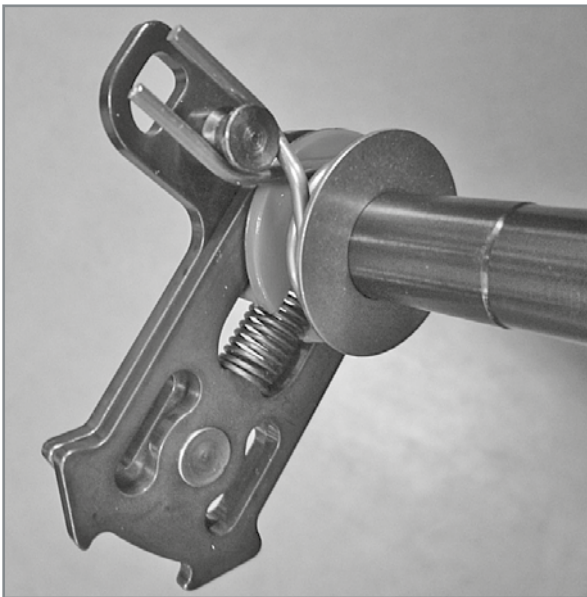

Gearshift drive shaft: note the gearshift return spring position.

The gearshift return spring must be positioned as in the figure to be able to carry out its function.

3.8.2 EXTERNAL GEARSHIFT ASSEMBLY

Keeping the stop lever moved **1** in such a way that the spring is compressed, position the stop cam **2** on the protruding end of the desmodromic gearshift (external right crankcase). The stop cam has only one correct position which is determined by the particular shape of the end of the desmodromic device and of the bottom part of the stop cam.

Proceed mounting the tightening screw **3** M6x30 between the stop cam and the desmodromic gearshift, after having applied medium-resistance sealant: fasten to the indicated torque.

Insert the drive shaft together with the washer in its seat keeping the return spring **4** of the movable pawl pressed.

Wishing to test the correct functioning of the entire unit, you just need to temporarily couple the external gearshift lever and to simulate the operation of changing gears, by lifting and lowering the gearshift lever and having the mainshaft of the gear unit rotate. The whole device works properly if abnormal jamming does not occur.

If the unit runs without oil, the device makes more noise than usual.

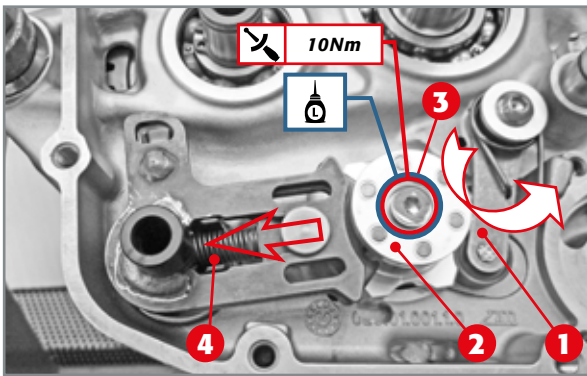

POSITIONING OF STOP CAM ON DESMODROMIC DEVICE

- 1) Stop lever;
- 2) Stop cam;
- 3) Screw M6x30;
- 4) Movable pawl return spring.

3.9 KICKSTARTER DEVICE - (OPTIONAL)

Before coupling the kickstarter to the crankcase half, some controls must be carried out.

3.9.1 CHECKING THE KICKSTART SHAFT UNIT AND ASSEMBLY

In order to disassemble all the parts of the kickstart shaft, pull off the washer **11** at the end of the shaft (on the side of the spring **16**), the spring **16**, the kickstart sleeve **14** and the lever return spring **8**, which must be pulled in the radial direction so that it is extracted from its hole to be unfastened from the shaft. Pull out the kickstart spacer **9**.

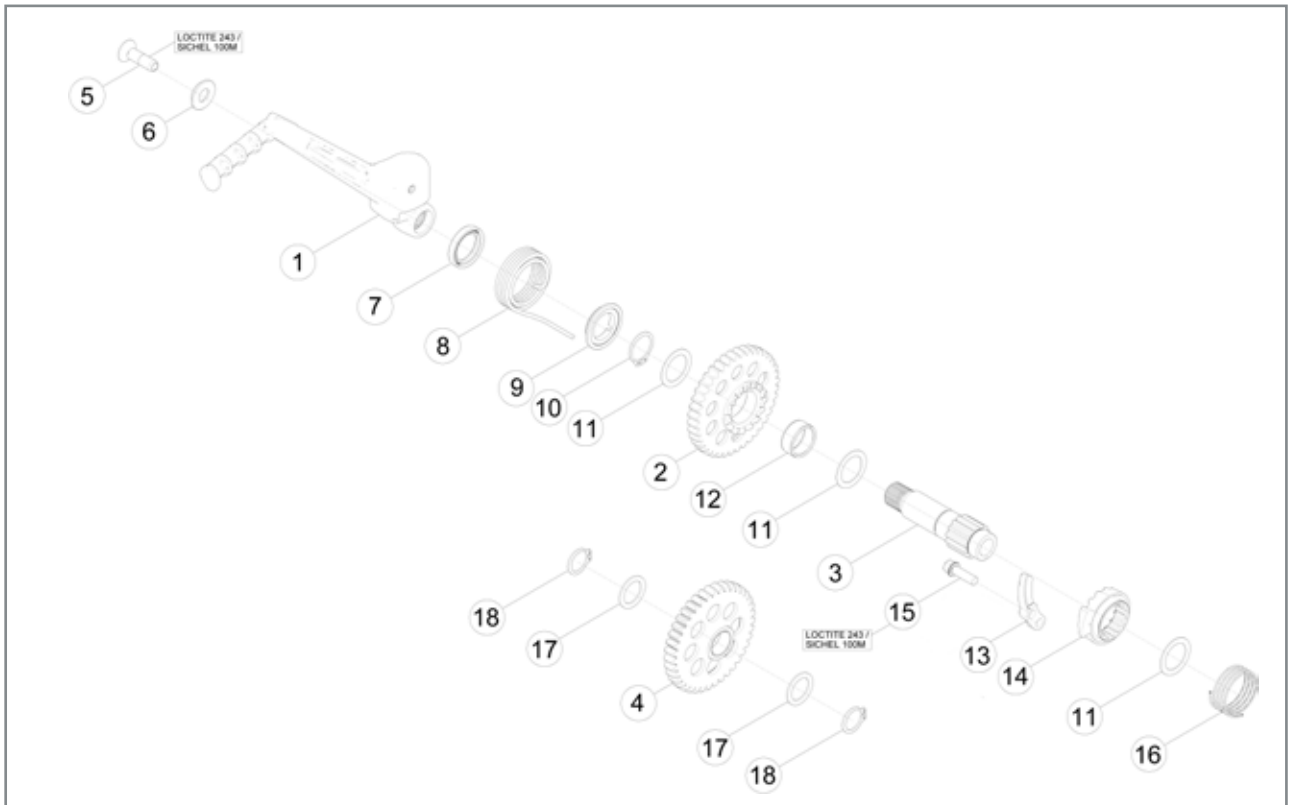

EXPLODED VIEW OF COMPLETE KICKSTART SHAFT:

- 2) Kickstart gear;
- 3) Kickstart shaft;
- 8) Kickstart return spring;
- 9) Kickstart spacer;
- 10) Circlip 20E;
- 11) Washer thickness 20x28x1 DIN 988;
- 12) Roller bearing K20x24x10;
- 14) Kickstart sleeve;
- 16) Spring.

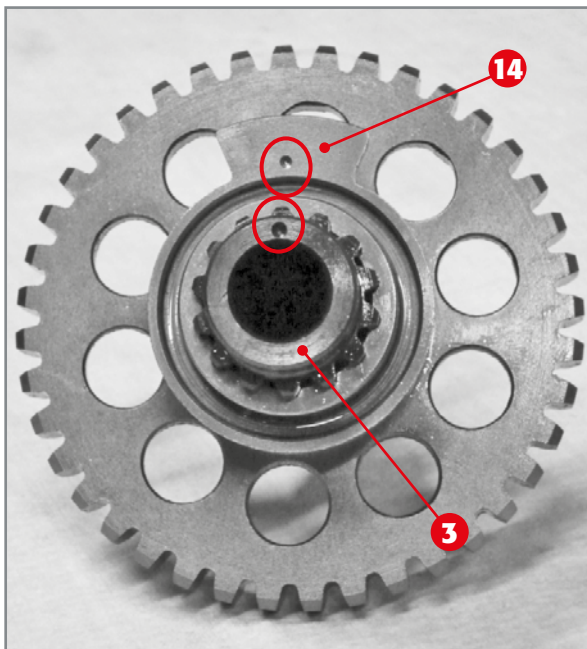

Positioning of sleeve on small shaft.

Widen the circlip **10**, thus slipping off the washer **11**, and the kickstart gear **2** as well the roller bearing **12** and the washer **11**. This frees the kickstart shaft **3** from all other elements.

Make sure that the side of the kickstart gear teeth **2** have no signs of meshing or superficial wear. Make sure that the front teeth (sleeve side **14**) are not chipped. Replace any element that has the aforementioned defects.

Make sure that the front teeth of the sleeve **14** are not chipped and that the spring **16** is capable of putting enough pressure on the sleeve **14** so that this can pull the wheel **2**.

Also check to make sure that the washers have no abnormal or excessive wear. If so, have them replaced. Make sure that the spring **8** has no cracks or abnormal deformation. Have it replaced if it is not able to bring the external kickstart lever back to the rest position.

For reassembly, proceed inversely compared to the previously-described disassembly procedures. Pay attention to the correct positioning of the sleeve **14** with respect to the shaft **3**. The front of the shaft has a reference sign, just as the sleeve does **14**: the two references must match.

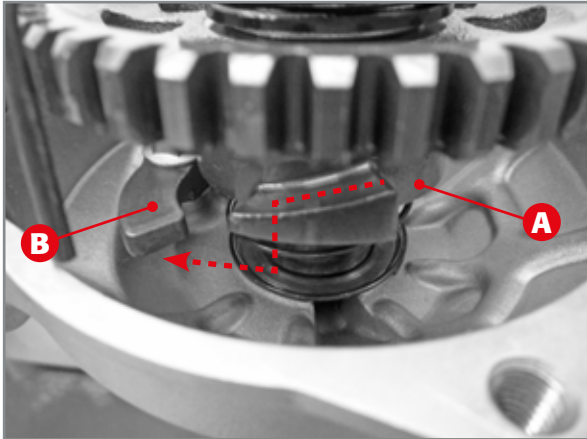

Positioning of sleeve A below ramp B.

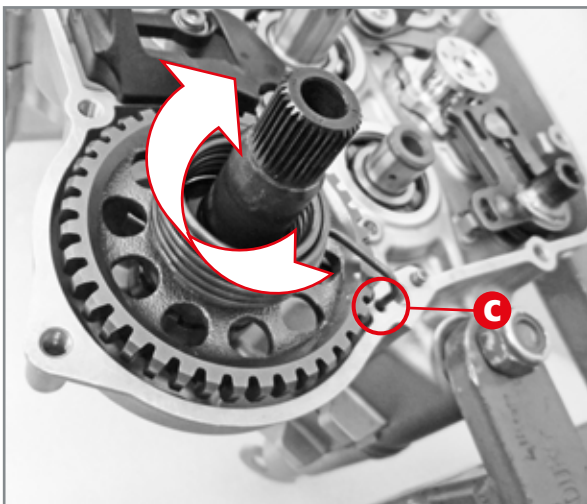

Insertion of kickstart return spring.

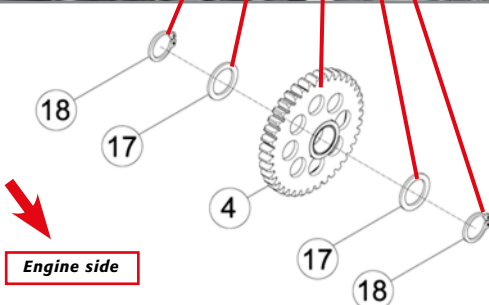
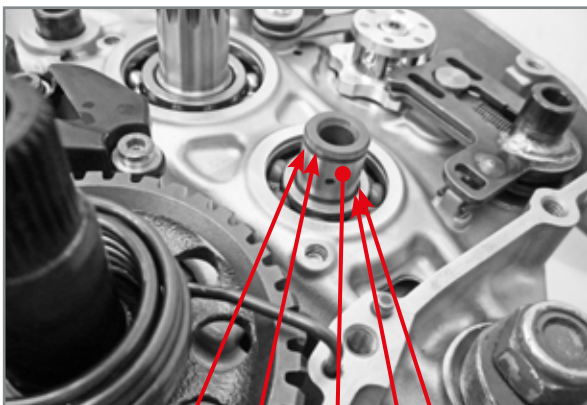

Kickstart device unit coupled to the crankcase.

3.9.2 ASSEMBLY OF KICKSTART-ER DEVICE

Insert the complete kickstart shaft in its housing keeping the thin-striped facing outwards and making sure that the ramp **A** on the kickstart sleeve is positioned below the ramp **B** bolted onto the right crankcase half (external side).

Turn the spring clockwise until it fits into the specific hole **C**.

Insert in the slot on the protruding segment of the secondary shaft: the circlip **18**, the washer **17**, the idler wheel **4** followed by the washer **17** and the circlip **18** as shown in the figure.



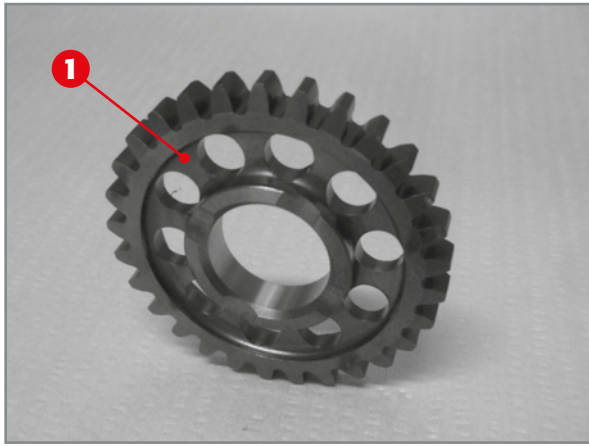

Idler wheel 1.

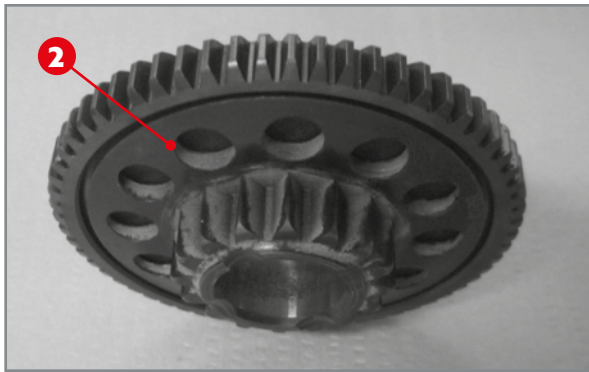

Torque limiter 2.

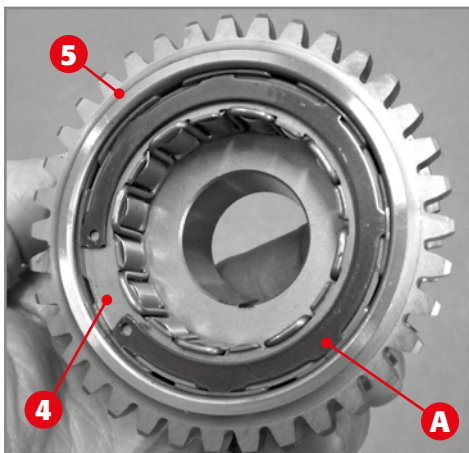

Free wheel coupled to the primary gear.

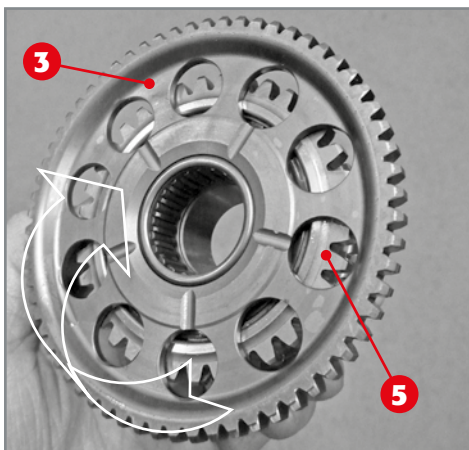

Primary gear complete with free wheel coupled to ignition gear.

3.10 ELECTRICAL STARTER UNIT AND PRIMARY GEAR

Carry out the following checks before assembly.

3.10.1 CHECKING ELECTRICAL STARTER DEVICE ELEMENTS

Make sure that the teeth of all the gearwheels of the device are intact, free from chipping or signs or abnormal wear.

Pay attention to the teeth of the idler wheels **1** and torque limiter **2** and between the gears and respective support pins. Replace them if they show signs of meshing or seizure.

Make sure there are no traces of meshing on the housing of the roller bearing on the starter gear **3**. Mount the starter gear temporarily on the crankshaft, together with the roller bearing and check to see if there is excessive play.

To check the correct functioning of the free wheel **4** proceed as follows.

Insert the starter gear **3** on the free wheel **4** and primary gear unit **5**. Keeping the primary gear blocked **5** and turning the kickstart gear **3** clockwise, it must run freely. Turning the kickstart gear **3** anti-clockwise, it must be blocked without idling.

To replace the free wheel, disassemble the special circlip **A** and remove the free wheel.

During disassembly make sure that the lugs on the outer edge of the special circlip **A** are coupled in the slots of the free wheel and in the groove inside the primary gear.

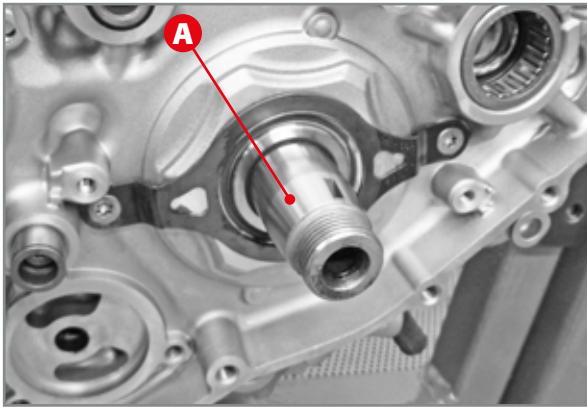

Conical segment A on right side of crankshaft.

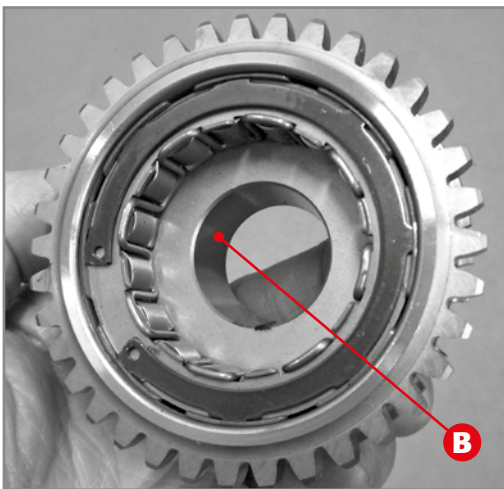

Conical segment B main gear.

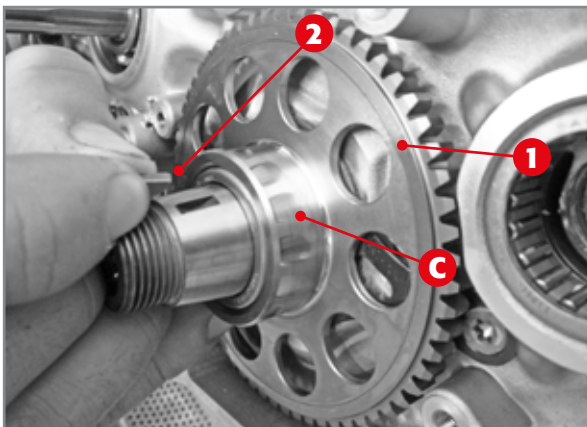

Positioning Woodruff key in specific seat.

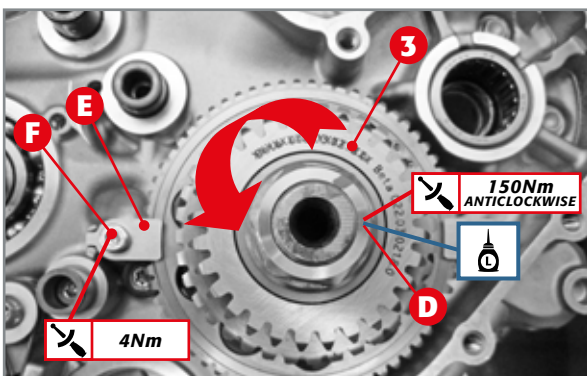

Coupling primary gear to crankshaft.

3.10.2 COUPLING IGNITION AND PRIMARY GEARS TO THE MOTOR

Thoroughly degrease the conical part A on the right side of the crankshaft and B of the primary gear.

Lubricate the segment C of the starter gear 1 with motor oil and couple it to the crankshaft. Insert the Woodruff key 2 in the specific seat.

Apply the primary gear 3 to the crankshaft and while turning the gear clockwise, push it towards the crankcase half until you perceive meshing between the gear and the Woodruff key.

Insert the locking nut D applying the threading with a medium strength threadlocker and tighten to the indicated torque.

Attention:
it must be tightened anti-clockwise.

Apply the two safety plates E bound to the casing with screws F. Tighten to 4Nm.



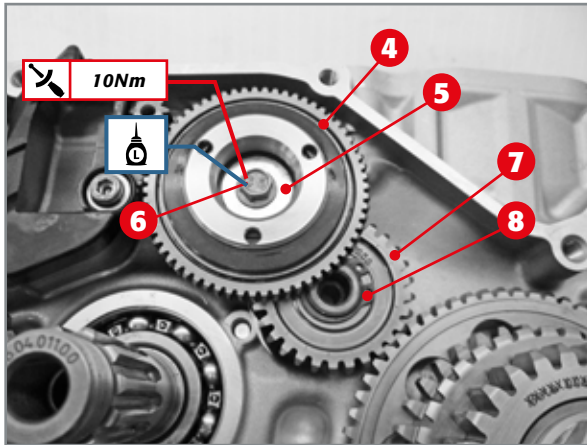

Coupling electrical starter gear unit.

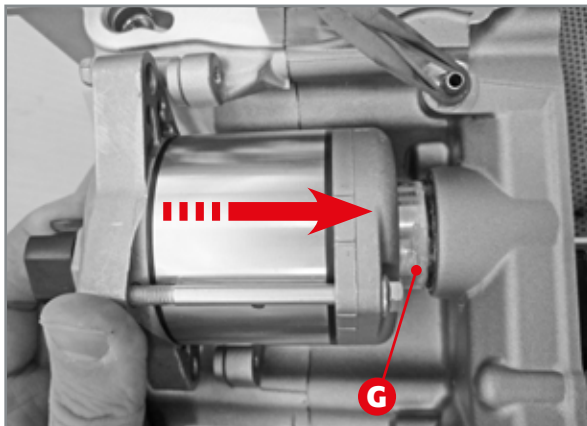
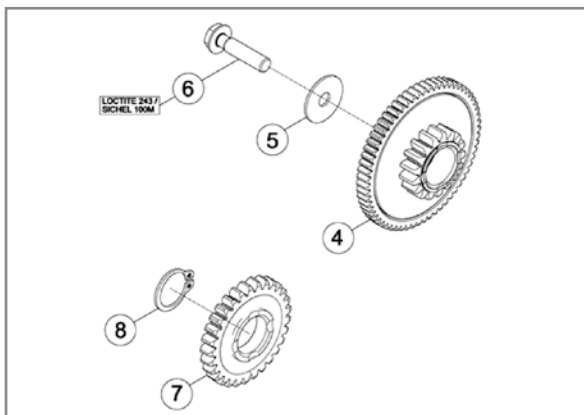

*Insertion of the start motor in the crankcase half.
Note zone F to be greased.*

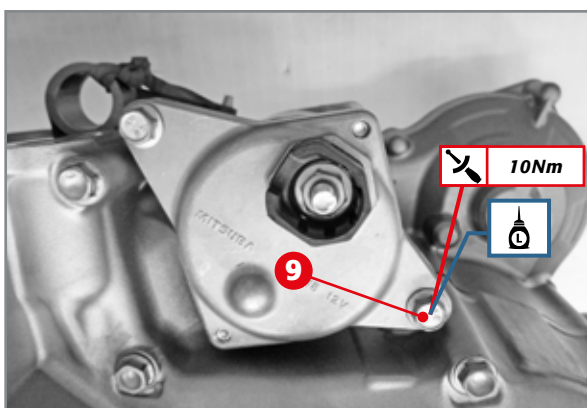

The two fixing screws 9 of the start motor.

Couple the idler wheel **7** to the pin and apply the circlip **8**.

Couple the torque limiter **4** to the pin turning the gearwheel with the smaller diameter towards the crankcase half. Insert the washer **5** and the screw **6** after having spread the threading with medium strength threadlocker.

Tighten the screw to the indicated torque.

Apply a light layer of grease in the area **G** of the start motor and insert the motor in its housing.

Apply medium strength threadlocker on the two screws **9** and tighten them to the indicated torque.

3.11 OIL PUMPS: INSPECTION AND REASSEMBLY

As shown in paragraph 1.5, the motor is equipped with two oil pumps: one is for intake (higher displacement) located in the outside of the left crankcase half and the other for high-pressure (less displacement) located on the outside of the right crankcase half. The two pumps are driven by a gear cascade meshing with the clutch case.

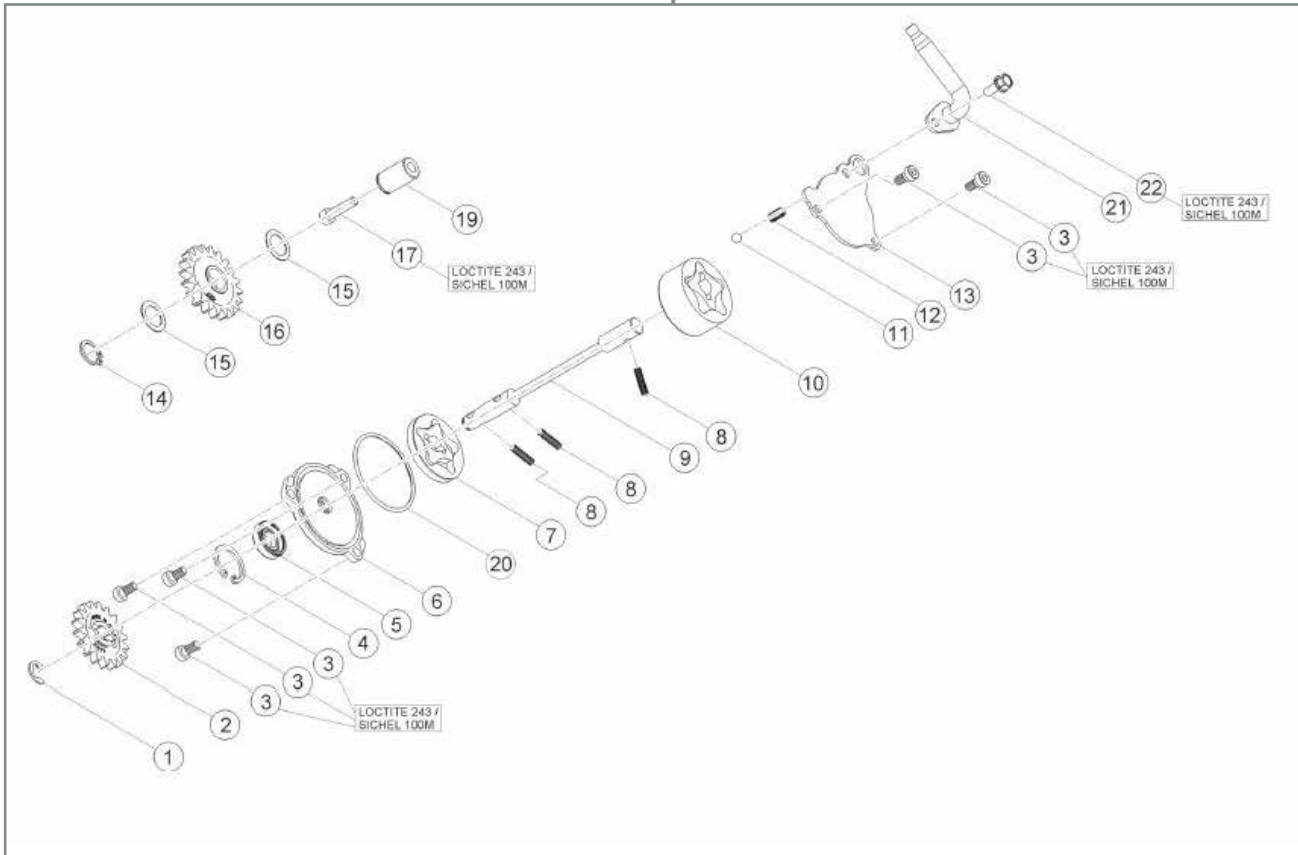

EXPLODED VIEW OF OIL PUMP UNIT.

- 1) Benzing ring;
- 2) Oil pump gear;
- 3) Screw M5x10;
- 4) Circlip JS24;
- 5) Oil seal;
- 6) High-pressure pump cover;
- 7) High-pressure (or delivery) oil pump;
- 8) Roller;
- 9) Pump drive shaft;
- 10) Low-pressure (or intake) oil pump; 11) Ball;
- 12) Spring;
- 13) Low-pressure pump cover;
- 14) Circlip A13;
- 15) Thrust washer 13x19x0.5;
- 16) Oil pump idler gear;
- 17) Screw M5x20;
- 19) Pin;
- 20) O-ring
- 21) Lubrication plate;
- 22) Flanged bolt M5x12.

Proper operation of the pump depends:

- On the sliding surface with the rotors;
- On the radial play between the two rotors and between the external rotor and the crankcase;
- On the axial play of the rotors respect to the sliding surfaces;
- On the O-ring seal and the oil seal (on the high-pressure pump cover).





Oil intake pump: note the dot on the two rotors. The dot must face the inside of the engine.

Should the sliding surfaces with the rotors present deep or evident traces of corrosion, replace the deteriorated part.

To measure the radial play between the internal and external rotor and between the external rotor and the crankcase, proceed as follows:

Insert the two rotors in their specific seat with the reference dot facing the inside of the engine.

Using a thickness gauge, check that the play does not exceed that allowed, equal to:

Maximum radial play: 0.20mm

Take a thickness gauge again and a rectified reference surface and verify that the axial play does not exceed the maximum allowed amount:

Maximum axial play: 0.1mm

Should play be greater, replace the rotors.

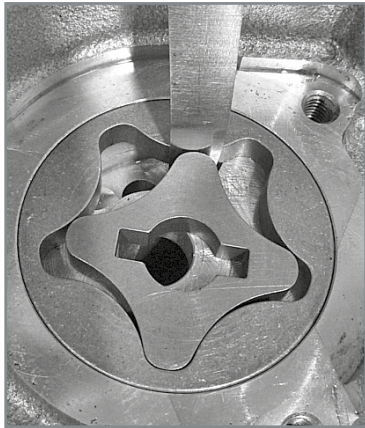

Evaluation of radial play between internal and external rotor.

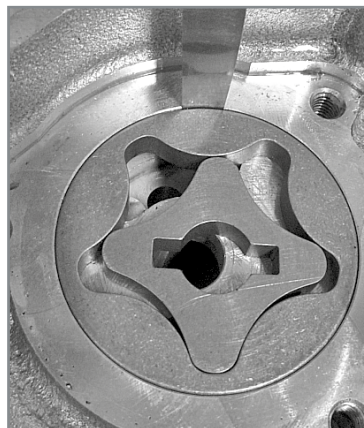

Evaluation of radial play between external rotor and crankcase.

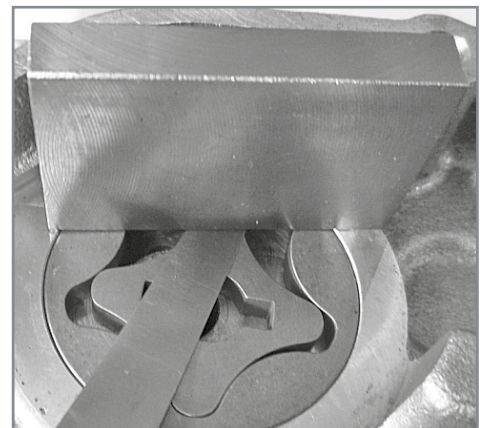

Evaluation of axial play between rotors and sliding surfaces.

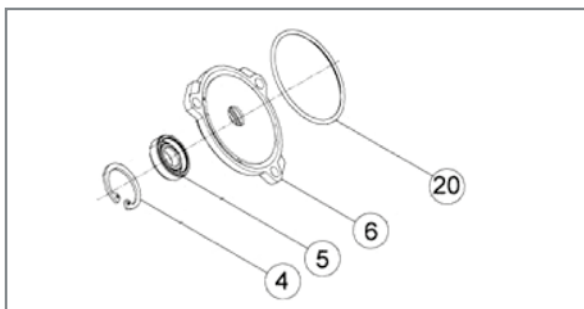

Exploded view of high-pressure pump cover. 4) Circlip JS24; 5) Oil seal 10x22.6; 6) Oil pump cover; 20) O-ring 45x2.

As to the high-pressure pump (located in the outside right crankcase half), one must check that the oil seal **5** is not worn (it is recommended to replace it). In order to disassembly it, the circlip **4** must be removed. Check the state of use of the O-ring **20** and replace it if needed.

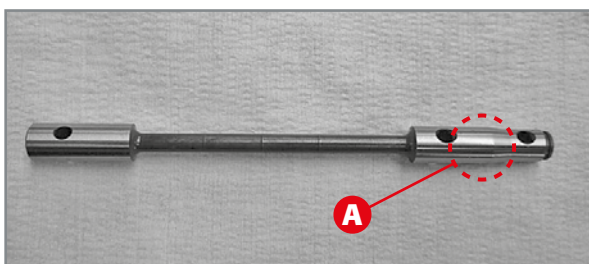

Checking oil pump control shaft.

Also check that the drive shaft is not too marked in the area **A** where the oil seal slides.

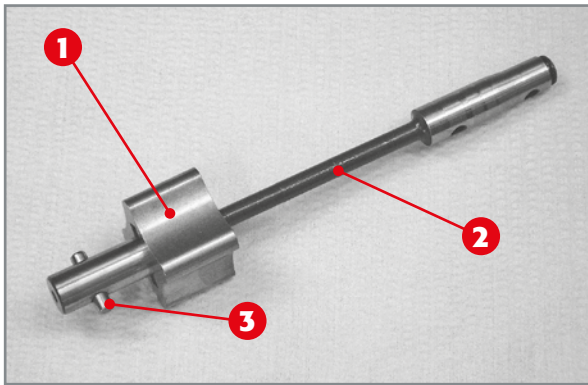

Shaft intake pump internal rotor and roller unit.

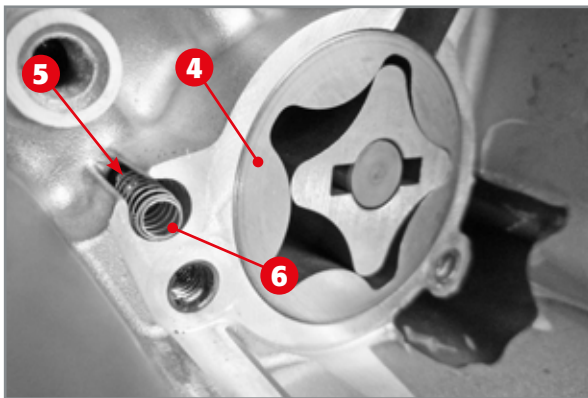

Complete intake pump coupled to the crankcase.

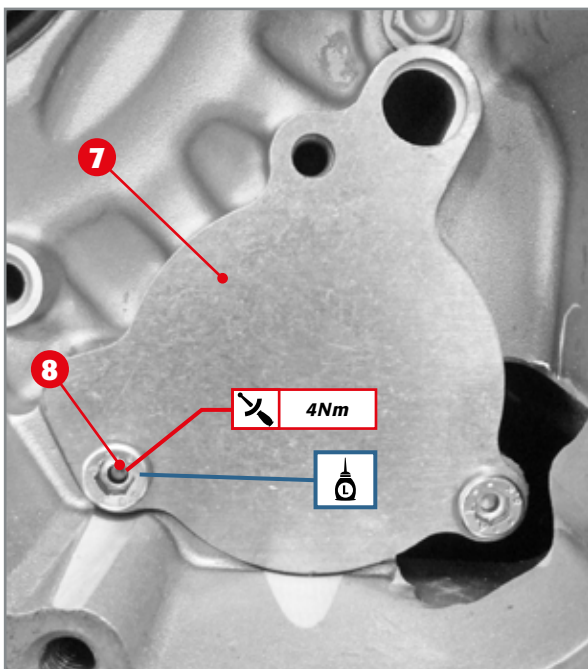

Coupling the oil intake pump cover to the crankcase.

3.11.1 INTAKE PUMP ASSEMBLY

Insert the internal rotor **1** on the shaft **2** so that the dot on the front of the rotor faces inwards. Then insert the roller **3** on the shaft.

Use motor oil to lubricate the seat of the rotors on the outside of the crankcase half, insert the external rotor **4** and the internal shaft-rotor unit in its proper seat.

Insert the ball **5** (diameter 5.5mm) and the respective compression spring **6**.

Lubricate with motor oil and, while rotating the protruding segment of the drive shaft (from the outside of the right crankcase half), make sure it rotates freely and does not jam.

Fasten the cover **7** to the crankcase with the three screws **8**, which must first be spread with medium strength threadlocker. These screws must be tightened to the indicated torque.

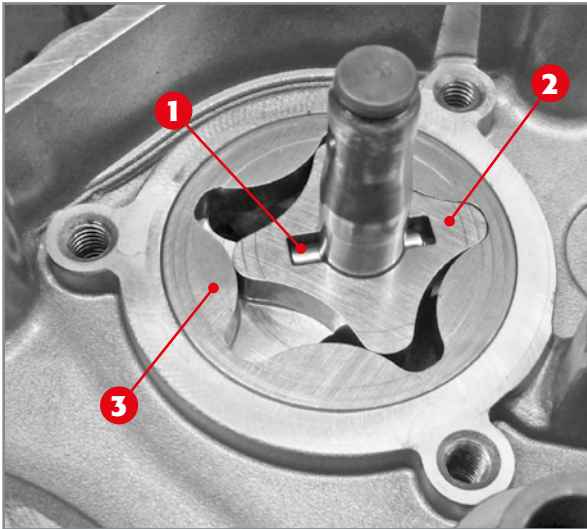

Coupling the high-pressure pump rotors to the control shaft.

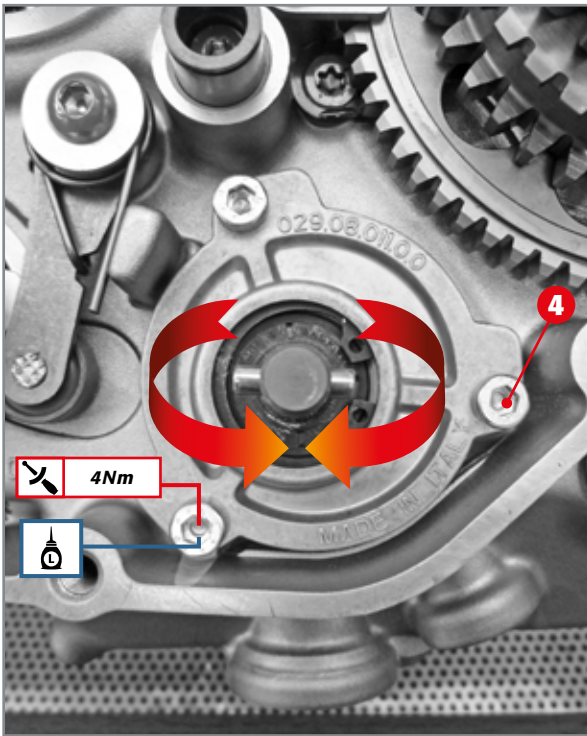

Coupling high-pressure pump cover to crankcase.

3.11.2 HIGH-PRESSURE PUMP AND CONTROL GEAR ASSEMBLY

Lubricate the area where the pump is housed (outside right crankcase half), and insert the roller in its hole 1. Then insert the internal rotor 2 and the external rotor 3, making sure to position them with the reference dot facing the inside of the engine.

Lubricate the pump body with motor oil.

Grease the oil seal, insert the cover in the end of the shaft and press towards the crankcase. Insert the three screws 4 after having applied them with spread medium strength threadlocker. Tighten them to the indicated torque.

Turn the shaft holding on to the protruding end and make sure it rotates freely without getting jammed.

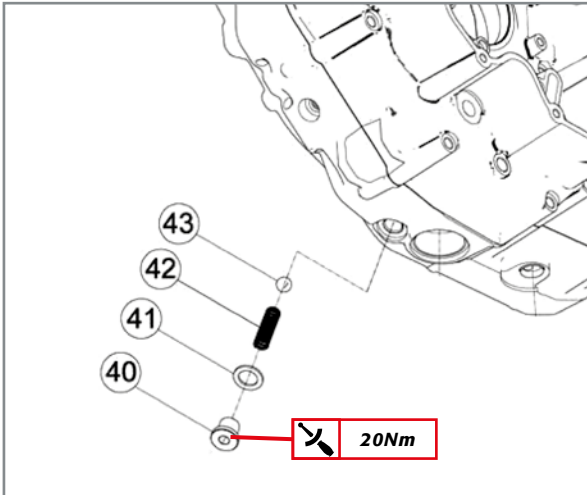

PRESSURE CONTROL VALVE.

- 40) Screw;
- 41) Thrust washer;
- 42) Spring;
- 43) Ball.

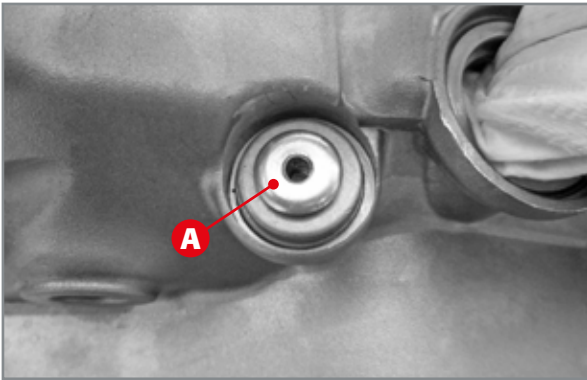

3.11.3 CHECKING AND ASSEMBLING THE PRESSURE CONTROL VALVE

The pressure control valve is made up of a ball **43**, spring **42**, calibrated washer **41** and screw **40**.

Check the length of the free spring on this component:

Service limit: 29.5mm

Tighten the screw to the indicated torque.

Attention: if one of these elements making up the control valve is not inserted, engine functioning will be jeopardised.

Attention: always restore the original thickness value of the washer **41**. If this must be replaced, replace it with one of the same original thickness.

Attention: once valve assembly is complete, apply a 6 mm diameter x 8 mm length aluminium rivet **A** in the hexagonal slot. This device prevents accidental dismounting of the pressure regulation valve.

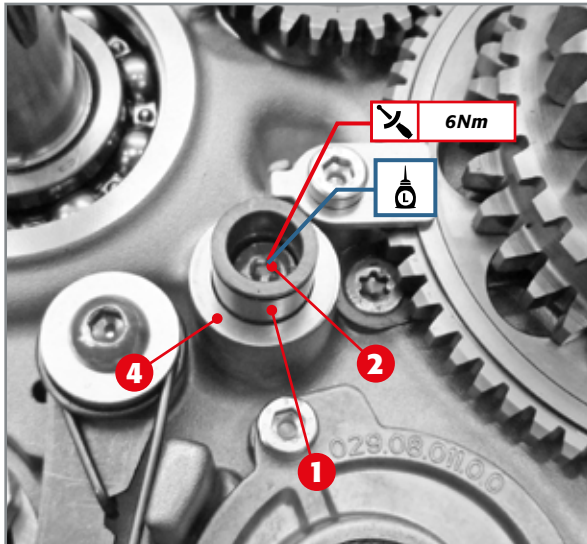

Oil pumps control gearwheels support pins.

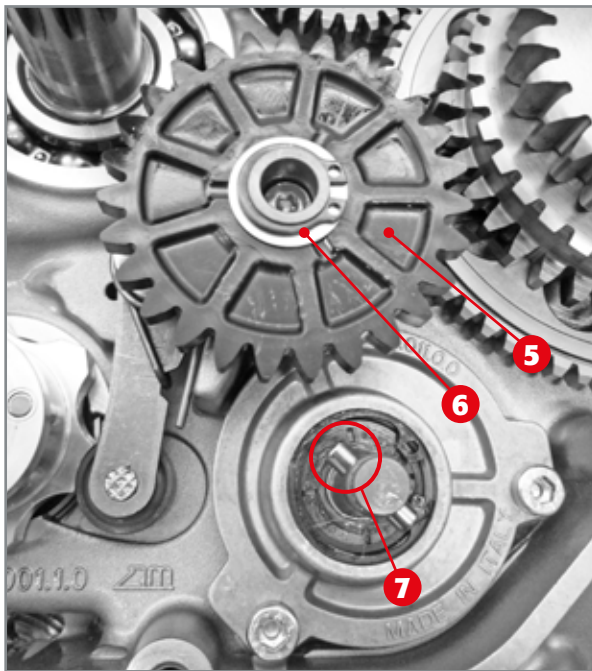

Coupling pump control gearwheels to crankcase.

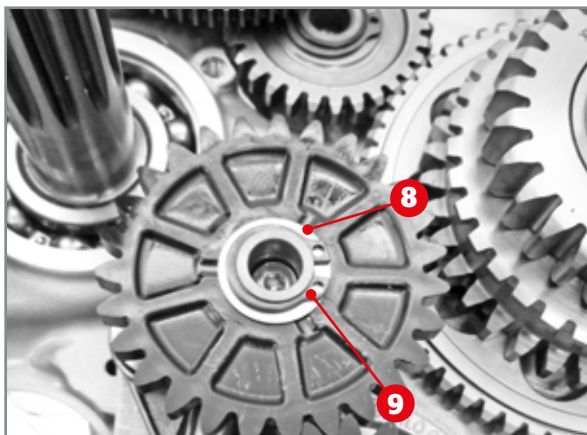

Coupling pump control wheel.

3.11.4 CHECKING AND ASSEMBLING THE OIL PUMP CONTROL GEARS

The oil pumps are controlled by a gear cascade driven by the clutch case.

The gearwheels, being made of plastic, must not have chips, grains or signs of abnormal wear.

If pump control idler wheel support pin 1 is dismantled, reconnect it to the crankcase half. The pin is fastened to the crankcase half with screw 2 (after application of medium strength threadlockers) and locked at the indicated torque.

Couple the thrust washer 4 to the pin and lubricate it with gear oil.

Couple the pump control idler wheel 5 to the pin so that the most protruding segment faces the casing.

Then insert the thrust washers 6 and circlips to prevent the wheels from coming off the pins.

Insert the roller 7 at the end of the pump control shaft.

Couple the oil pump control wheel 8 to the end of the shaft so that the groove on the gear inserts into the roller. Then apply the benzing ring 9, so that the gear does not slip off.

3.11.5 PAPER OIL FILTER INSERTION

Lubricate the rubber gasket on the filter. Insert the filter **1** into its housing and push it towards the inside of the engine as far as it can go.

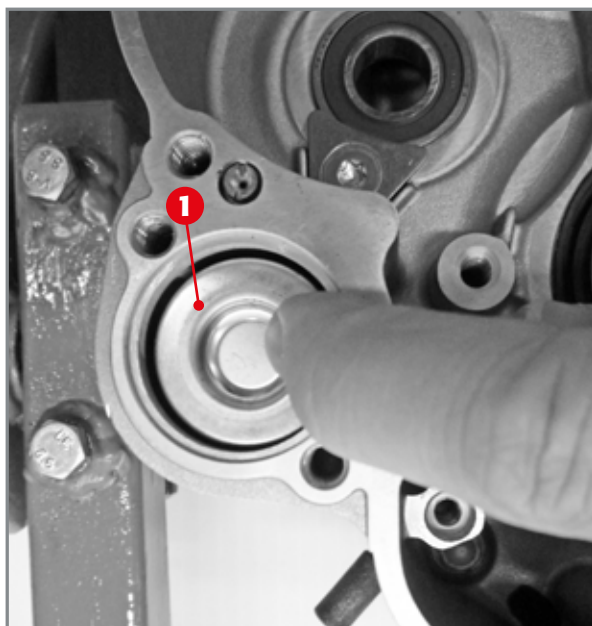

Oil pumps control gearwheels support pins.

Insert the O-ring **2** onto the oil filter cover **3** and apply the unit to the crankcase half.

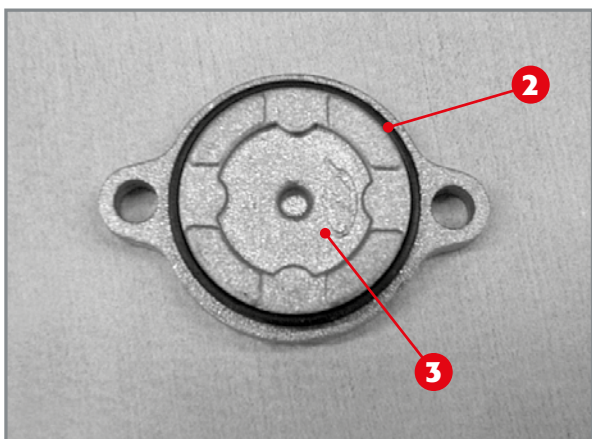

Paper oil filter cover complete with O-ring.

Apply the two screws **4** M6x16 to be tightened to the indicated torque.

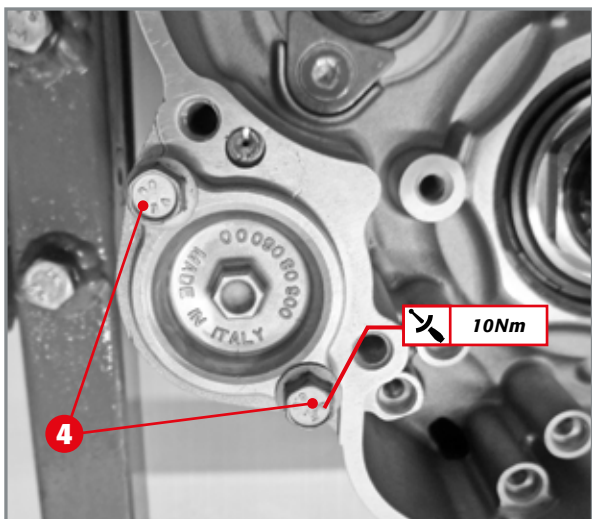

The two paper oil filter cover fastening screws.



EXPLODED VIEW OF COUNTERSHAFT

- 1) Shaft;
- 2) Counterweight;
- 7) Elastic washer
- 8) Nut M12x1

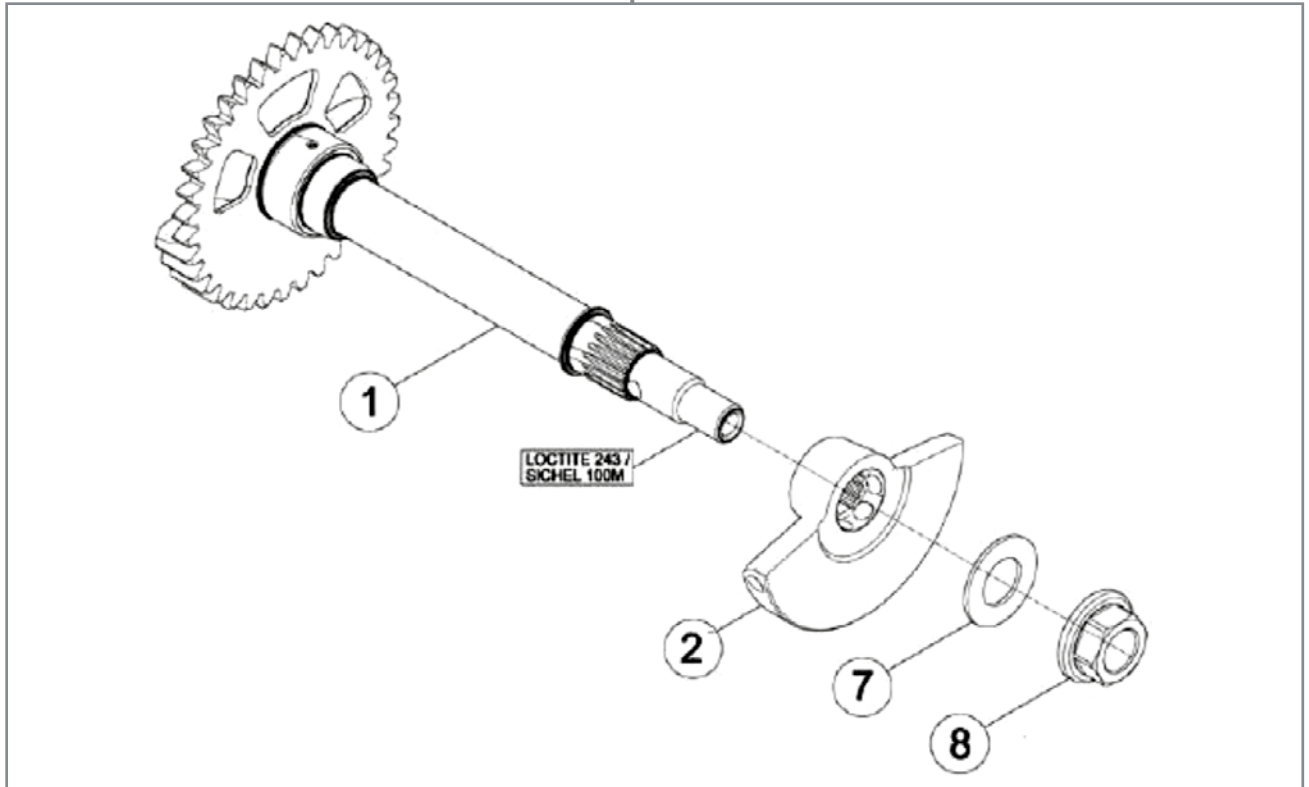
**3.11.6 CHECKING AND COUPLING THE COUNTERSHAFT**

Check the state of use of the areas where the shaft rests on the bearing. Should they show signs of abnormal wear, have the shaft replaced. Make sure that the toothed segment of the shaft does not have traces of abnormal wear.

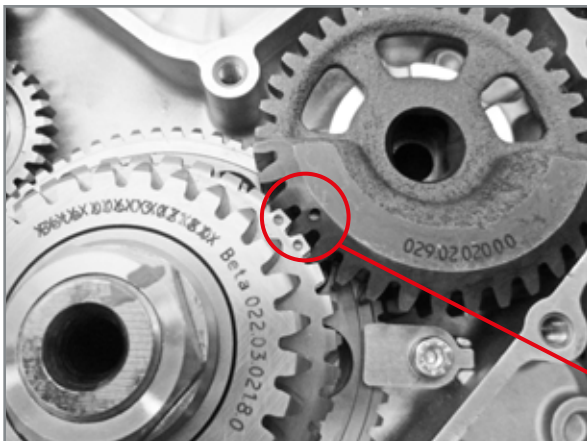

Coupling countershaft to crankcase.

Grease the oil seal and insert the countershaft in its seat. Position it so that the reference sign on the shaft is between the two reference signs on the primary gear.



Enlargement of references.

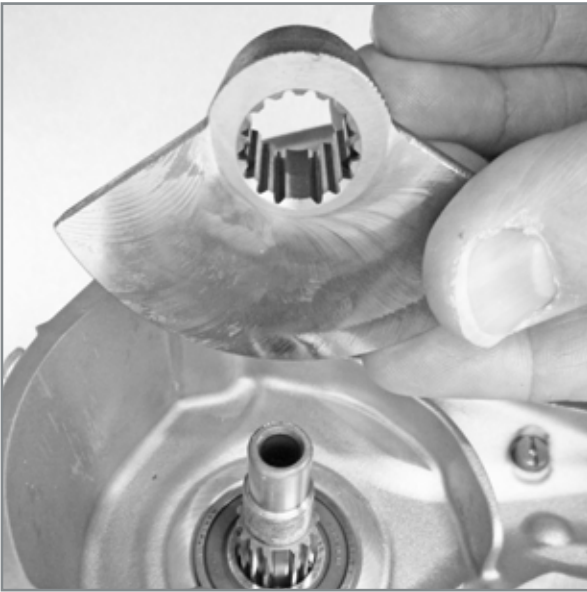

Coupling counterweight to countershaft.

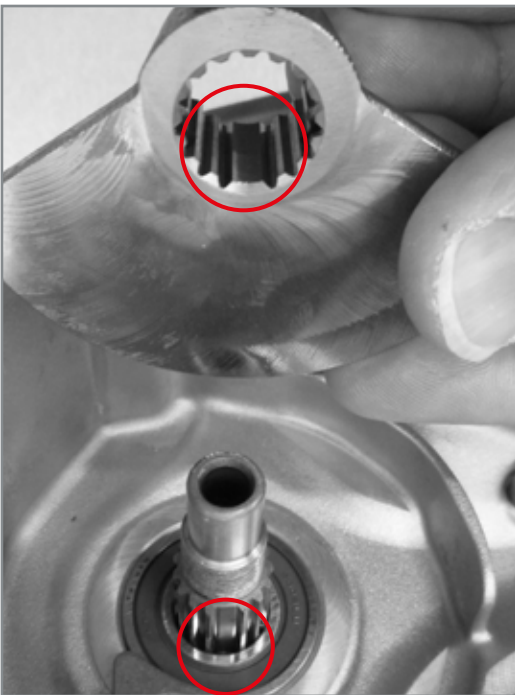

Detail of grooved profiles for coupling.

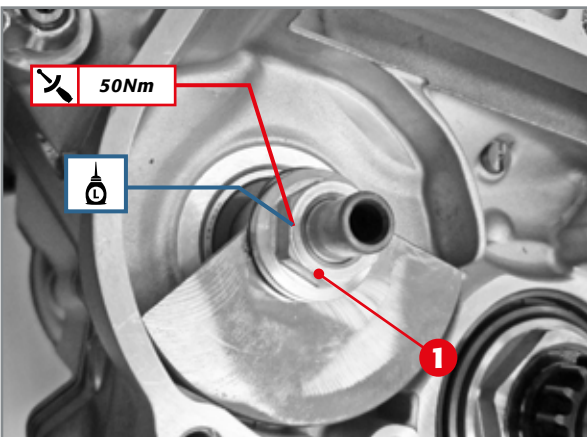

Countershaft nut.

While keeping the countershaft in place, insert the counterweight on the left side depending on the position set by the grooved shaft.

Then couple the elastic washer and the nut **1** after having applied medium strength thread-locker on their threading. The nut must be tightened to the indicated torque.

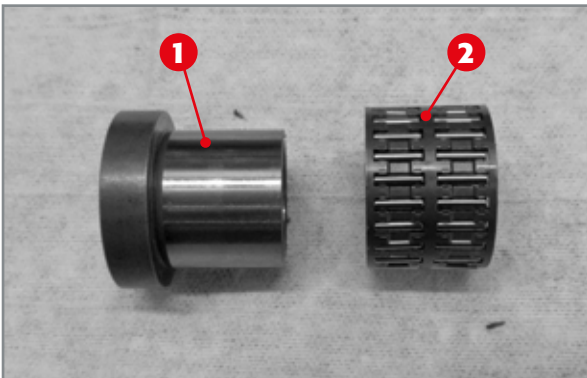
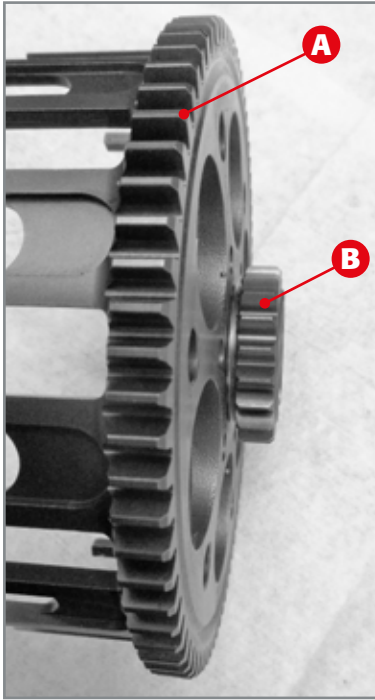

3.12 CLUTCH UNIT

Before reassembling the clutch unit, carry out some checks on the various components described below.

3.12.1 CHECKING THE CLUTCH CASE, ROLLER BEARING AND INTERNAL CENTRE BEARING

Before reassembling the clutch case, make sure that the sides of the teeth **A**, dedicated to main transmission and **B** dedicated to meshing with the kickstart idler gear and oil pumps, have no superficial nicks or abnormal wear.

Check the state of use of the internal centre bearing **1** which must have no traces of meshing or abnormal wear. Check the state of use of the roller bearing **2**. If it is worn, have it replaced.

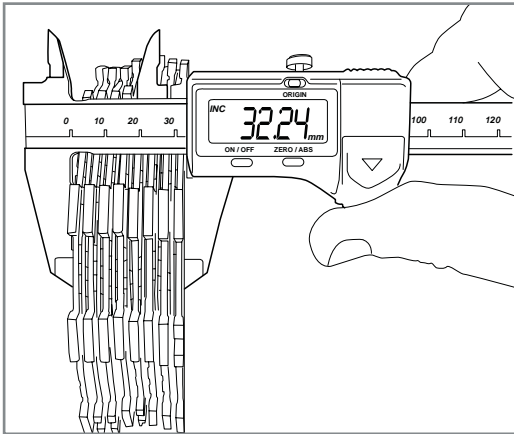

3.12.2 CHECK OF CLUTCH DISCS

The clutch discs are divided into driving and driven: eight driving discs and seven driven discs.

The driving discs have cork inserts on both sides which wear out due to the driven discs sliding on them. It is necessary to check that the thickness of the clutch pack (driven and driving discs) is not lower than a minimum set value equal to:

minimum thickness of complete disc pack: 31.6mm

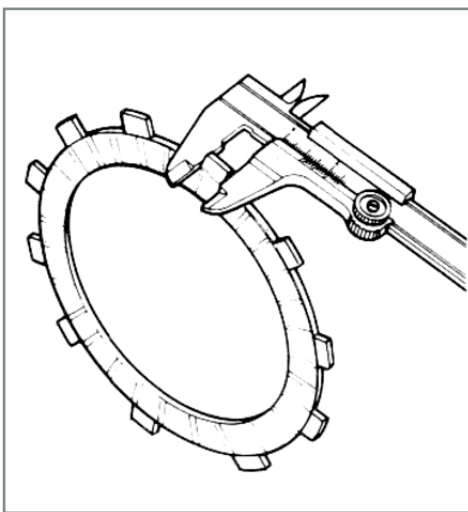

The other value that needs to be checked is the thickness of the teeth of each driving disc. They must not be less than the minimum value fixed at:

minimum driving disc tooth thickness: 13.3mm

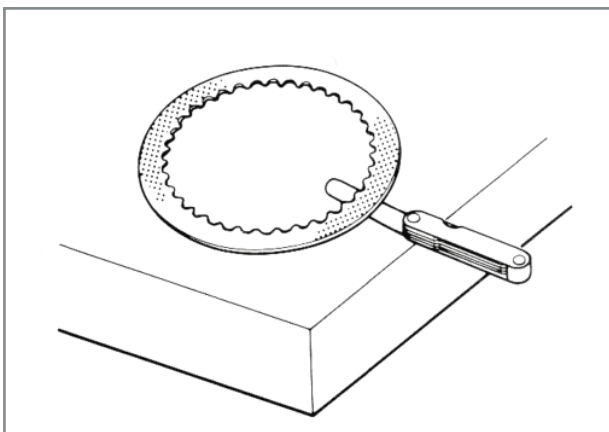

Also check the distortion of the driving discs. This operation is done by placing the driving discs on a perfectly flat surface and using a thickness gauge to check that the gap between the disc and the surface is not greater than:

allowable distortion of driven discs: 0.10mm

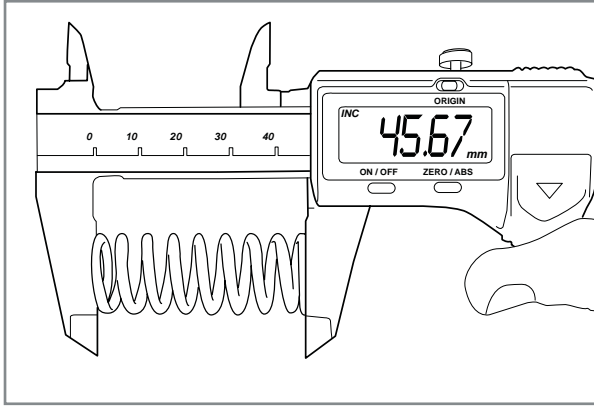

3.12.3 CHECKING THE SPRINGS

To ensure the correct pressure between the clutch discs, the state of the springs must be checked. The minimum acceptable length must be:

**minimum clutch spring length:
45mm**

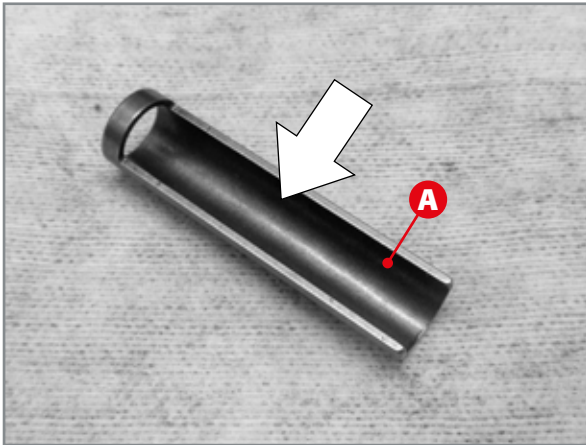

3.12.4 CLUTCH DRUM AND CAP CHECK

The clutch drum engages with the driven clutch discs by means of the sliding pins **a**: make sure that the area shown in the figure is free from meshing or abnormal wear. If so, replace the sliding pins.



Check that the disc friction area is free from scratches, meshing or abnormal wear. If so, replace the clutch drum

Also control that the radial holes present on the clutch drum are not obstructed and are free from sediments.

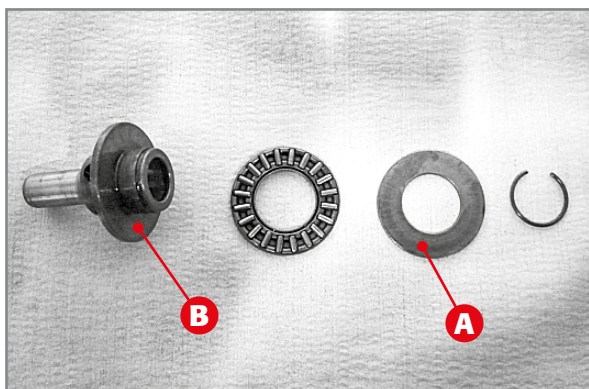

Thrust bearing device.

3.12.5 CHECKING THE THRUST BEARING DEVICE

Check the state of use of the thrust bearing and the surfaces upon which it rests.

In order to check the thrusting bearing, just see if it slides. When the device is assembled, simulate rotation of the front centre bearing **A** with respect to the rear one **B**.

Pay attention to the presence of traces of meshing or wear on the sliding surfaces. In the event of signs of deterioration replace the entire unit.

3.12.6 CLUTCH UNIT ASSEMBLY

Lubricate the end of the primary gearbox shaft, the internal centre bearing **4** and the roller bearing **5**. Fit the roller bearing **5** and the centre bearing **4** on the clutch case **1**. Mount the unit on the primary shaft; in order to facilitate insertion of the clutch case, slightly turn the kickstart idler gear (optional), the idler gear for oil pump control and the case itself, thus facilitating meshing. Mount the washer **6**, which the clutch drum **2** rests against. Fit the sliding pins **35** on the drum. Fit the safety washer **7** and after having applied medium strength thread-locker, couple the lock nut **8**.

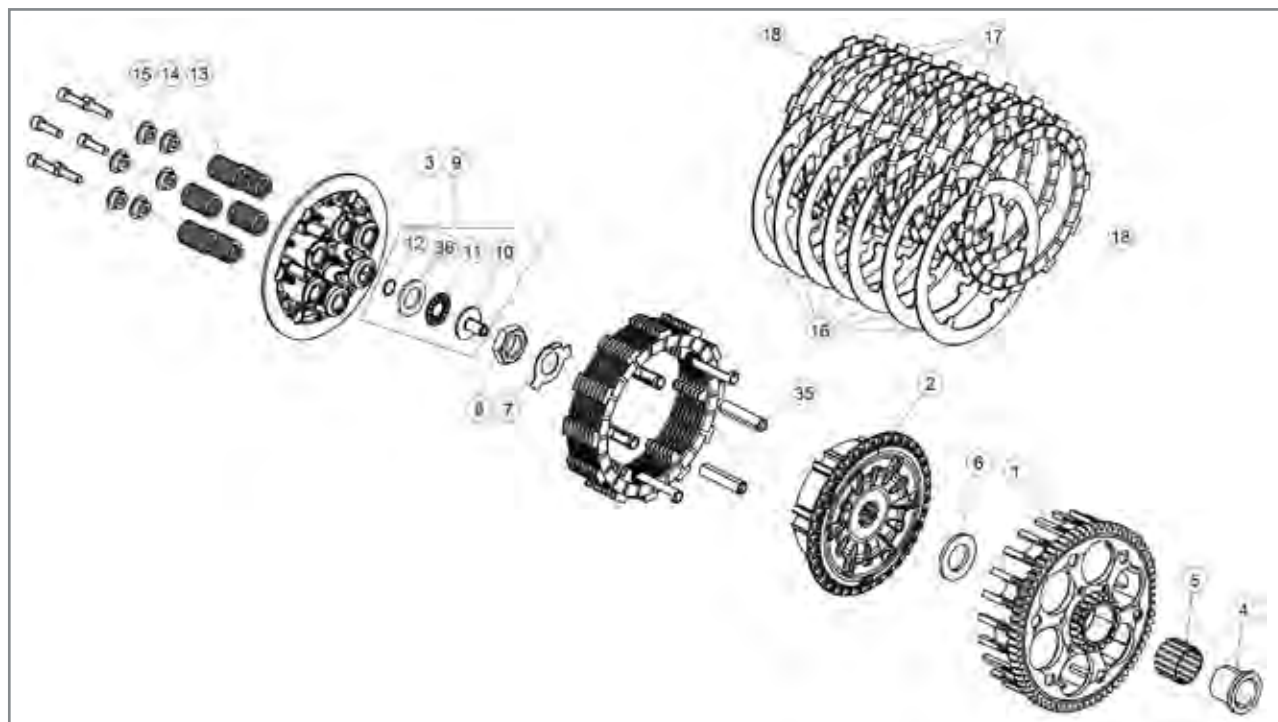

EXPLODED VIEW OF CLUTCH UNIT.

1) Complete case; 2) Clutch drum; 3) Clutch cap; 4) Internal centre bearing; 5) Roller bearing 26x30x22; 6) Washer; 7) Safety washer; 8) Nut M18x1.5; 9) Overall thrust bearing; 10) Clutch body rod coupling; 11) Thrust bearing; 12) Circlip RB14; 13) Clutch spring; 14) Clutch spring retainer; 15) Screw TCCE 6.20; 16) Driven discs; 17) Driving discs - GREEN edge; 18) Driving disc - BLUE edge; 35) Guide pin; 36) Thrust bearing washer.



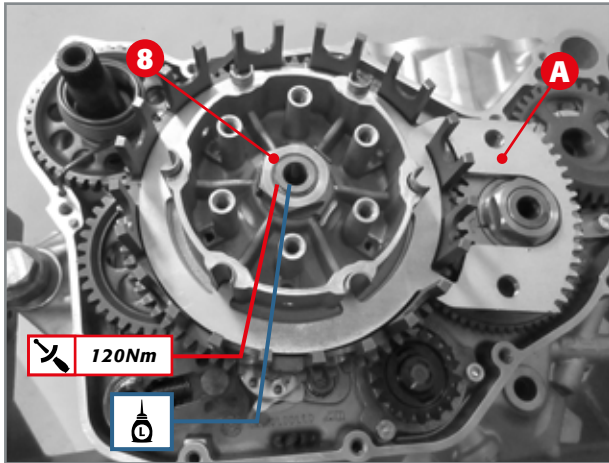

To unscrew the nut **8** the clutch drum must be blocked with a relevant tool **A** (code 029.14.002.50.00). Tighten at the specified torque.

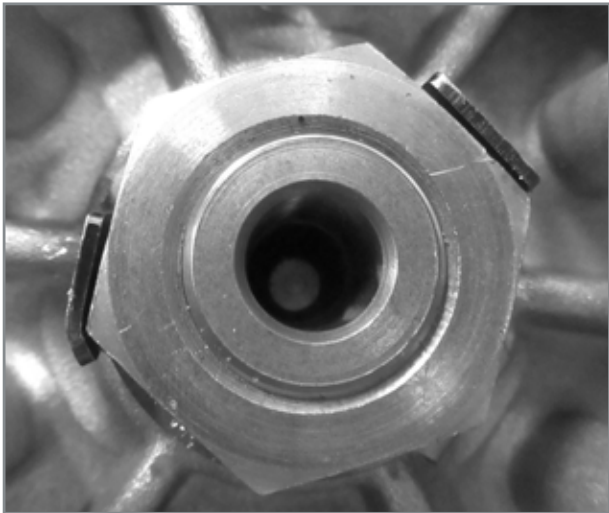

Having tightened the nut, bend the two blocking flaps on the safety plate.

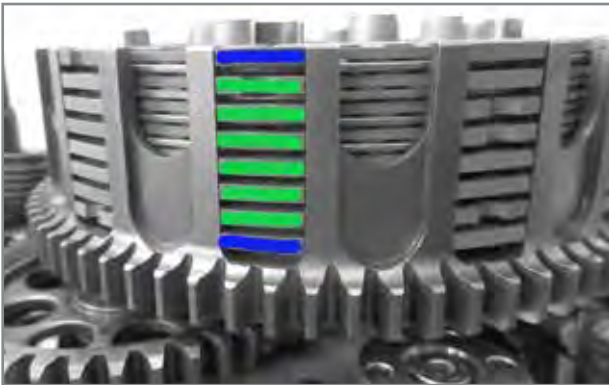

Lubricate the clutch discs with gear oil and apply the driving disc with **BLUE** edge and a driven disc. Then alternate the driving discs with **GREEN** edge and the driven discs. The other driving disc with **BLUE** edge will close the disc pack.

Notice that the driven discs must be inserted so that the radius on the teeth faces inwards towards the engine.

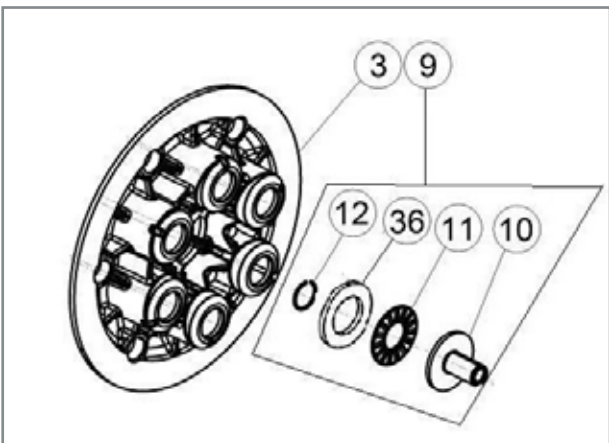

Insert the overall thrust bearing **9** (after having lubricated it with transmission oil) in the hole on the gearbox mainshaft and check its free axial sliding.

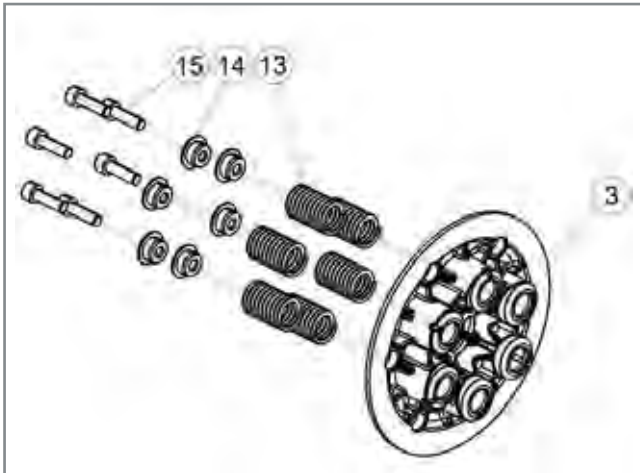

Close the clutch unit with the clutch cap **3**, the springs **13**, the spring retainers **14** and the screws **15**.

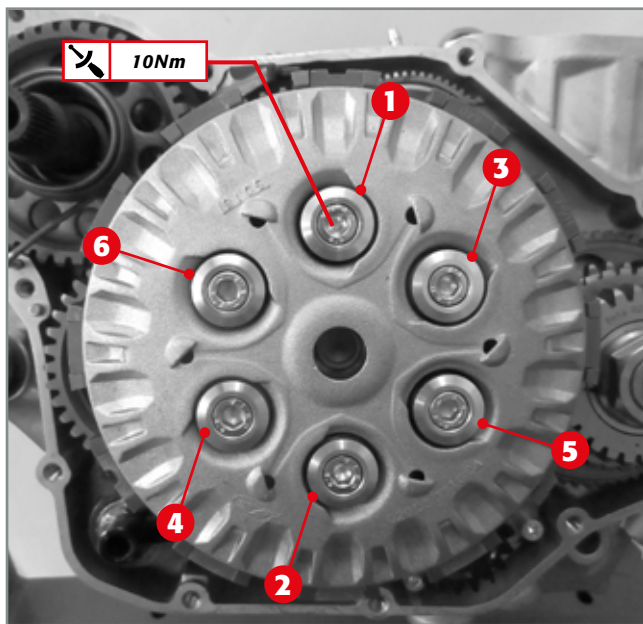

Tighten the screws to the indicated torque.

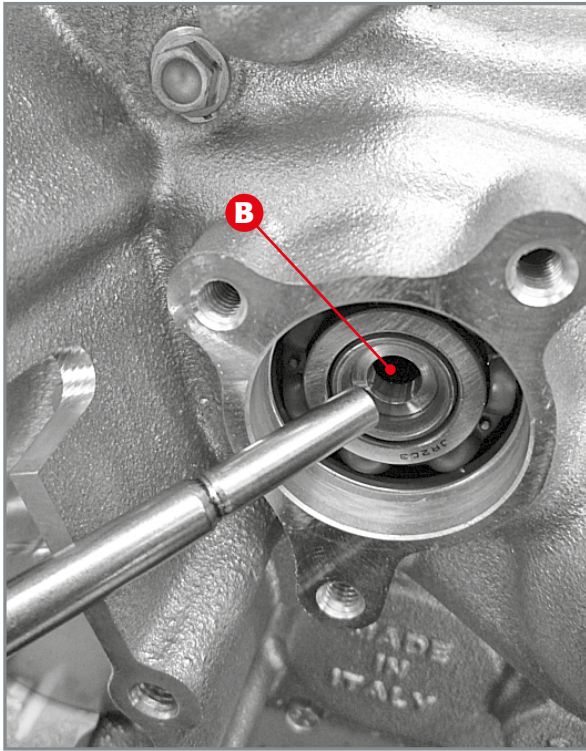

Insertion of clutch rod in housing B.

Insert the clutch rod in the seat **B** from the left side of the engine, turning the smaller section towards the inside of the engine.

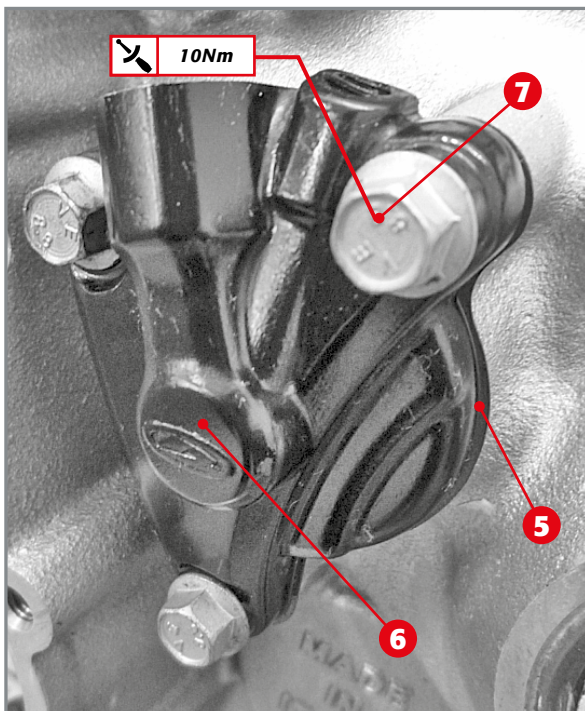

Application of the gasket 5, actuator 6, screw 7 M6x30 and two screws 8 M6x20.

If only the clutch actuator pipe was removed during the disassembly of the engine from the vehicle, operating on the actuator as well, proceed as follows. Apply the gasket **5**, the complete hydraulic actuator **6** the M6x30 screw **7** and the two M6x20 screws **8** to the left crankcase half. Tighten the three screws to the indicated torque.

EXPLODED VIEW OF WATER PUMP

- 1) Drive shaft
- 2) O-ring 5.5x1;
- 3) Bearing 10x19x5;
- 4) Oil seal 12x30x7;
- 5) Bush 8x12x10;
- 6) Impeller;
- 7) Washer;
- 8) Blind nut M6x1;
- 9) Gasket;
- 10) Gasket cover;
- 11) Washer;
- 12) Screw M6x40.

3.13 COOLANT PUMP

The water pump must guarantee, depending on the set rotation speed, the correct flow rate of the coolant in order to extract the needed amount of heat from the thermal unit.

The shaft **1** is supported by two bearings **3** and sealing of coolant and gear oil is ensured by the O-ring **2** and oil seal **4**.

The impeller **6** is fastened to the shaft **1** and the coupling is ensured by tightening the nut **8** onto the shaft **1**.

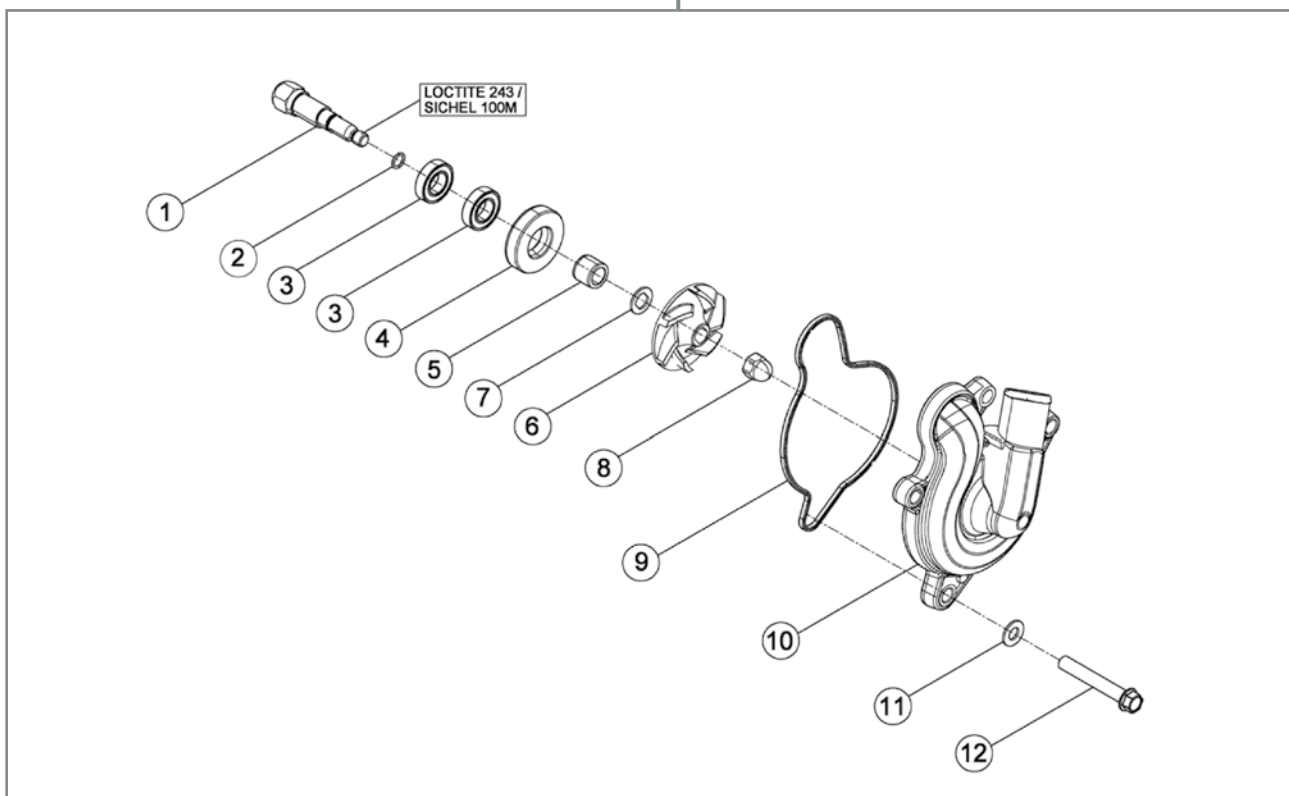

Complete internal clutch cover of water pump.

3.13.1 CHECKING PUMP UNIT AND DISASSEMBLY

Disassembly of the entire pump unit can be done only with the entire clutch cover removed. Disassembly of the pump unit is performed by removing the nut **8** which allows you to extract the impeller **6**, the washer **7**, and the shaft **1**. This can be removed by pressing the threaded part of shaft towards the inside of the clutch cover.

Extract the oil seal **4** and, heating the bearings **3**, remove them.

Once the shaft is pulled off **1** from the crankcase, it is recommended to replace the O-ring **2**. Replace the oil seal **4** every time and if the bush **5** is marked in the area of contact with the oil seal, replace it as well.

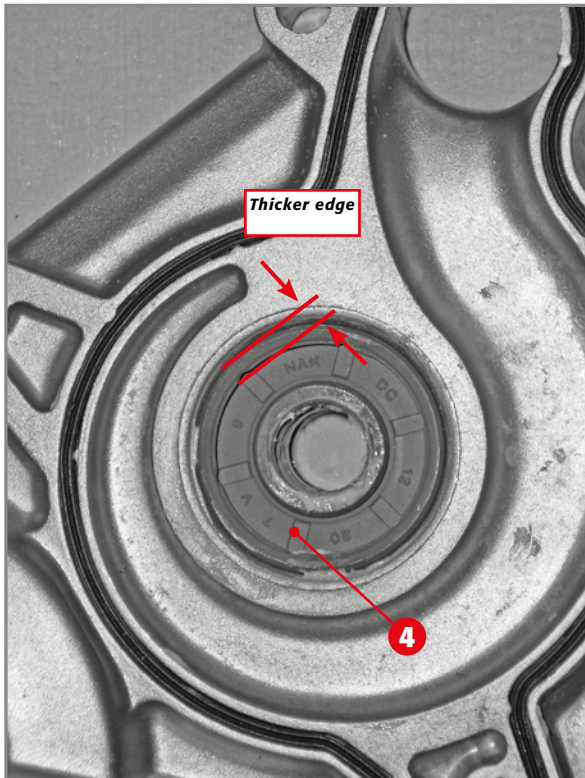

Application of oil seal on inner clutch cover.

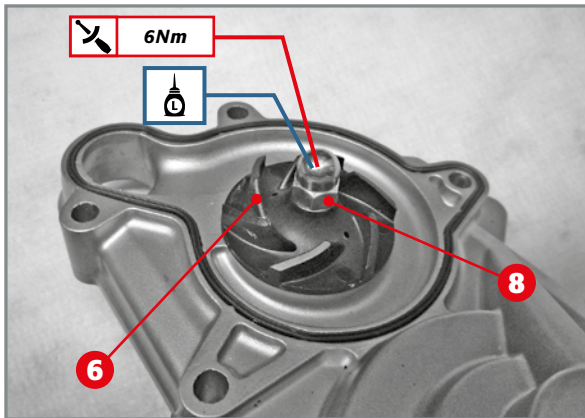

Complete coolant pump unit.

3.13.2 PUMP UNIT ASSEMBLY

Heat the concerned area to couple the bearings **3** to the inner clutch cover. They must be pushed until they are flush with the shoulders on the pump body.

Grease the oil seal housing. Position the oil seal **4** so that the thicker edge faces the outside of the cover. Insert the oil seal in the inner clutch cover, having it enter the seat very slowly to keep it from deteriorating.

Couple the shaft **1** with the O-ring **2** to the inner clutch cover and then insert the bush **5**, the washer **7** and the impeller **6**.

Then couple the blind nut **8** to the threaded segment of the shaft after having applied medium strength threadlocker. Tighten it to the indicated torque.

When coupling is complete, check that the pump unit turns freely without meshing or friction. Check the axial play of the pump unit. Make sure it is not beyond 0.3 mm.

It is recommended to replace the gasket in between the inner clutch cover and the pump cover.

3.14 ASSEMBLY OF COMPLETE CLUTCH COVER

Apply a new gasket **1** placed between the right crankcase half and the inner clutch cover using the two reference pins **2** to keep it in place.

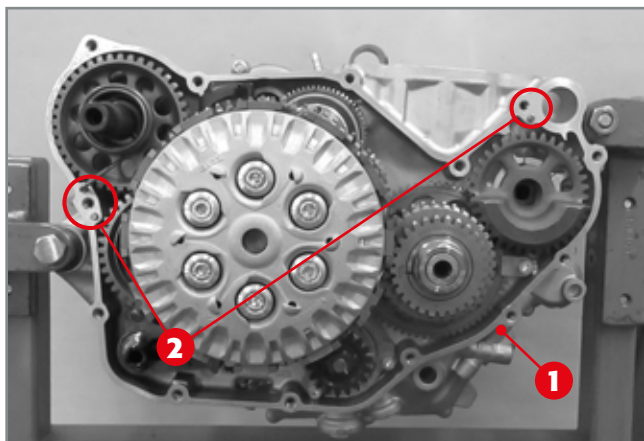

Positioning of gasket 1 and centring pins 2.



Application of complete inner clutch cover on right crankcase.

Couple the inner clutch cover to the right crankcase half and turn the water pump impeller until the pump shaft inserts perfectly in the housing on the countershaft which drives it.

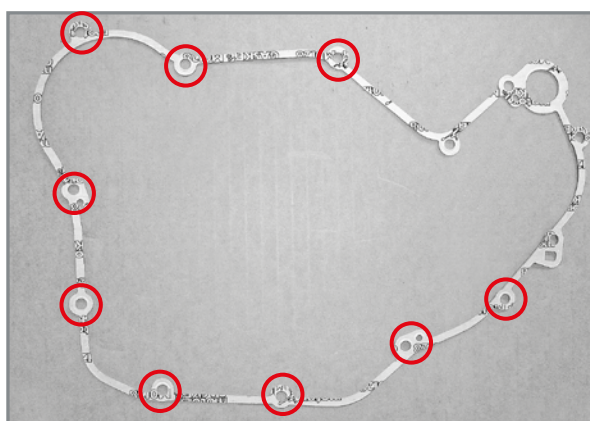

Positioning of M6x25 screws.

Apply the nine M6x25 screws as shown in the figure, tightening them by hand until they are flush.

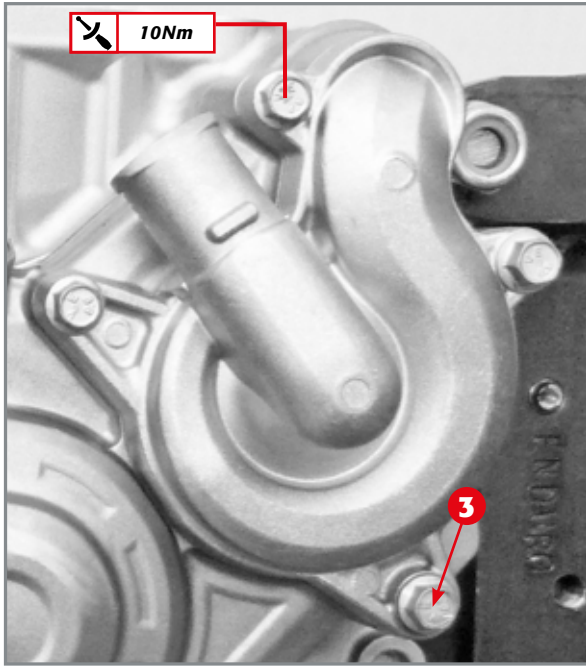

Coolant pump cover: pay attention to the washer 3.

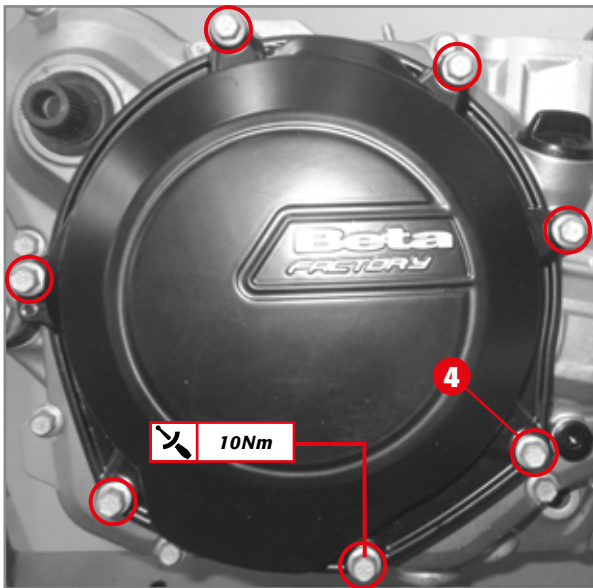

The screws 4 that fasten the outer clutch cover to the internal cover.

Couple the water pump cover to the inner clutch cover applying the M6x40 screws, making sure to apply the copper washer 3 to the lower screw of the pump cover.

Fasten all thirteen screws at the indicated torque following a criss-cross pattern.

If only the outer clutch cover was removed, put it back on the inner cover and fasten the 4 and tighten to the indicated torque.

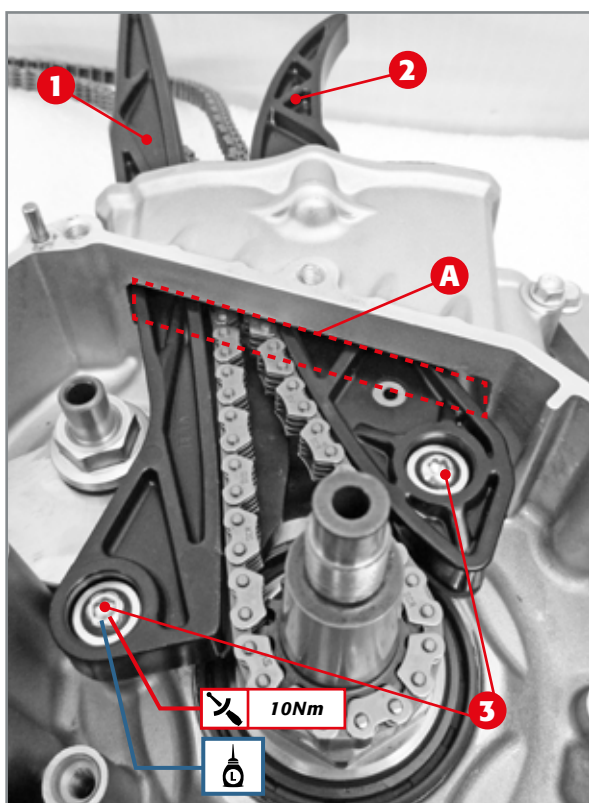

Timing chain with relative fixed and movable pads.

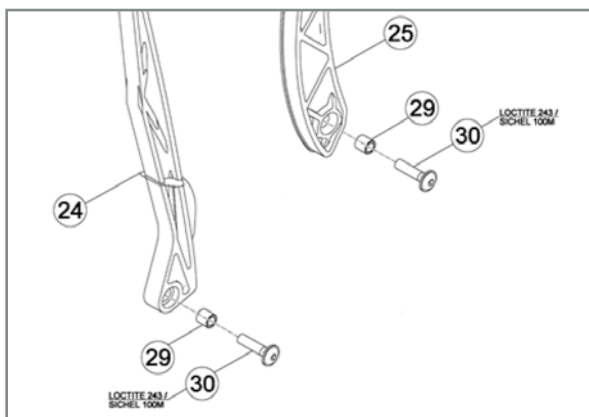

Mounting bushes in lower eyelets of pads.

3.15 CHECKING AND COUPLING OF TIMING CHAIN, FIXED AND MOBILE PADS

The chain has the task of transmitting motion from the crankshaft to the camshafts present on the cylinder head. The links must be checked to make sure there is no excessive radial or axial play between them.

The fixed and movable guides guarantee a correct movement of the chain. The hydraulic chain tensioner ensures correct tensioning.

Make sure that the guides do not have deep traces caused by the rotation of the chain.

In order to assemble the chain to the engine, just introduce it in the vertical passage compartment **A** on the left crankcase and insert it in the gear on the crankshaft.

Insert the fixed pad **1** and the movable pad **2** inside the compartment **A**. Insert the specific 6.2x9x9 bushes inside the lower eyelets of the pads. After having applied medium strength threadlocker, tighten the relative screws **3** to the indicated torque.

3.16 IGNITION SYSTEM

Before reassembling the ignition system, it is recommended to check its correct functioning. The ignition system is made up of the magnetic pick-up, the stator unit and the flywheel. The system is completed by the electronic control unit, the ignition coil and the spark plug, which are not dealt with in this text.

3.16.1 IGNITION SYSTEM CHECK

Accurately degrease the various elements and carry on with the checks.

The main check is the one concerning the electrical verification which can be done by using a standard tester. The resistance values detected at the terminal heads must respect those carried in the table (at 20°C).

Element	Cables	Strength values
Pick up	Red – Green	100Ω ± 20%
Stator	Black - Black	0,46Ω ±20%

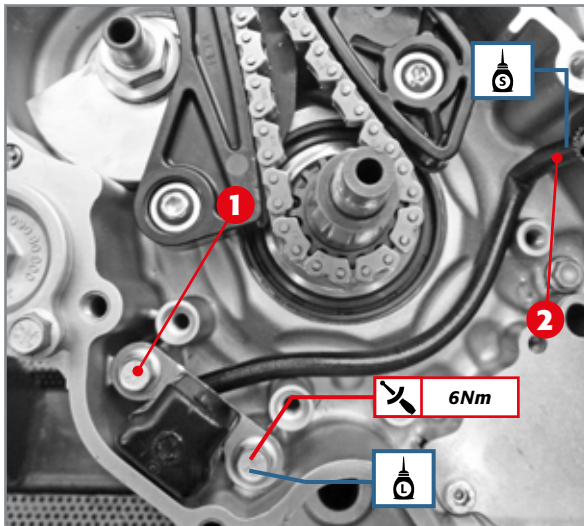

Coupling of pick up to crankcase.

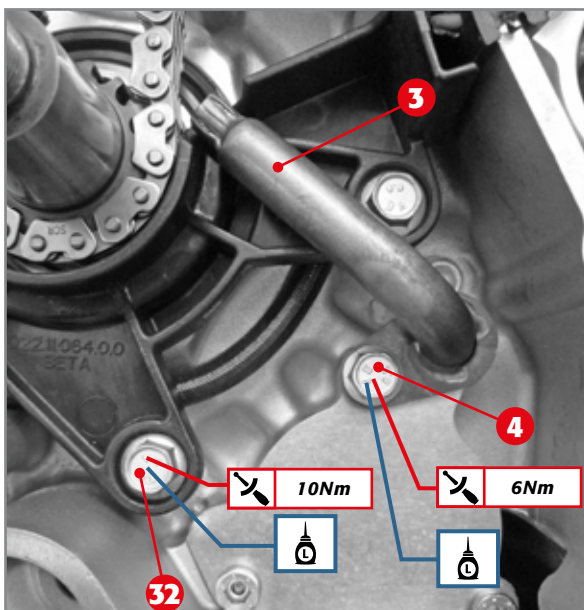

Coupling chain guard to crankcase.

3.16.2 COUPLING OF IGNITION SYSTEM TO CRANKCASE

Set the pick-up on the crankcase so that the two holes on its support coincide with the two outer holes on the crankcase.

Cover the threading of the two screws 1 with medium strength threadlocker and tighten them to the indicated torque.

Lay the cable on the crankcase half, apply the groove of the cable gland 2 with gasket paste (code 3625000000) and insert it in the specific housing in the crankcase, removing excess paste.

Couple the chain guard to the crankcase half, insert the two 6.2x9x9 bushes in the lower eyelets and couple the two screws 32 after having applied them with medium strength threadlocker. Then tighten them to the indicated torque

Attention: pay close attention so that the cables are well fastened to the wall of the crankcase halves near the cable gland.

Apply the oil jet 3 and the respective screw 4 that must be previously covered with medium strength threadlocker and then tightened to the indicated torque

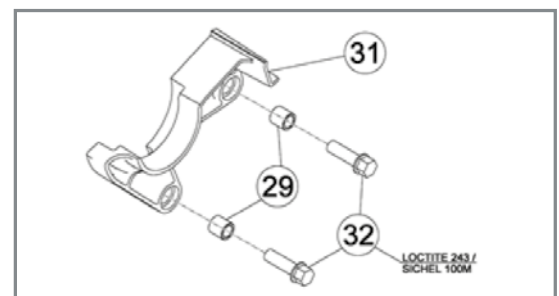

Mounting bushes in lower eyelets of chain guard.

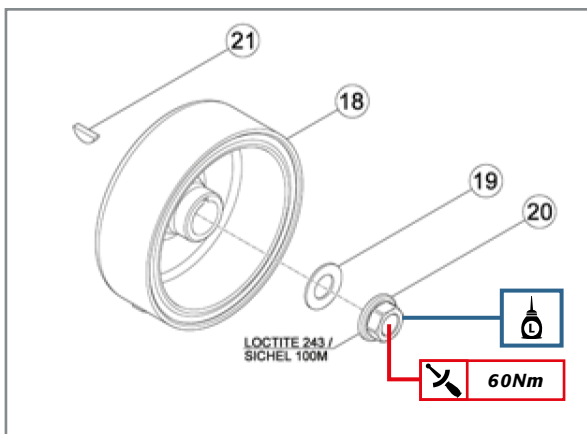

Exploded view of flywheel. 18) Flywheel; 19) Elastic washer; 20) Nut M12x1; 21) Woodruff key

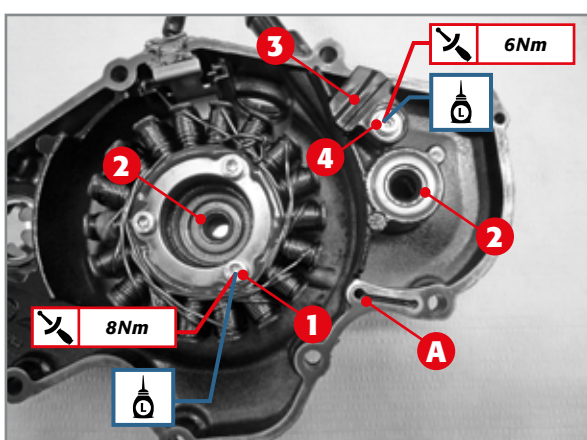

Thoroughly degrease the crankshaft conical section, apply the Woodruff key **21** in the appropriate groove present on the crankshaft, couple the flywheel **18**, the elastic washer **19** and the nut **20**, after having spread the threading with medium strength threadlocker. Tighten the nut to the indicated torque.

Couple the stator to the flywheel cover by means of screws **1**. Cover the threading with medium strength threadlocker and tighten them at the torque indicated.

Insert the cable gland in its specific seat and check its perfect sealing.

Check the state of use of the two oil seals **2**. If they are deteriorated, they must be replaced. Blow compressed air in the hole **A** making sure the lubrication pipe is perfectly clean. Also check the state of use of the chain guide **3**. If it is deteriorated, it must be replaced. In that case, before putting on the screw **4**, apply it with medium strength threadlocker and tighten it to the indicated torque.

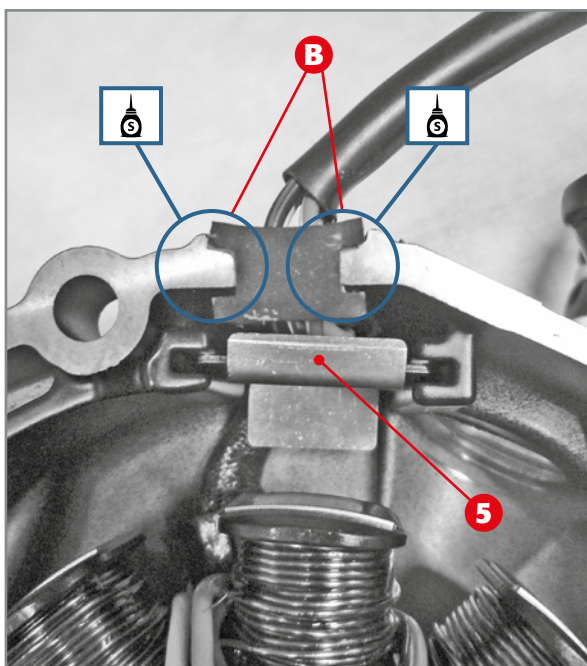

Reposition the plate **5** which must be inserted in the relevant guides and pressed towards the outside of the cover.

When coupling it to the left crankcase half, apply a drop of gasket paste (code 3625000000) in the two areas **B**, in order to ensure perfect sealing between the cover and the crankcase half in the concerned zone.

Application of cable protection plate **5**. zones **B** where a drop of gasket paste must be applied.



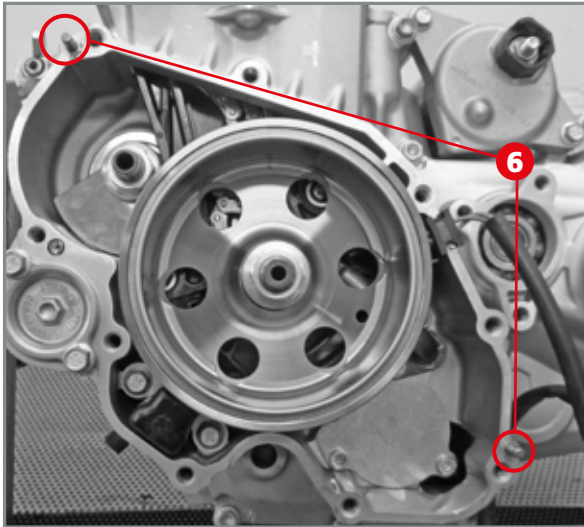

Insert the centring pins **6** on the crankcase and fasten a new gasket.

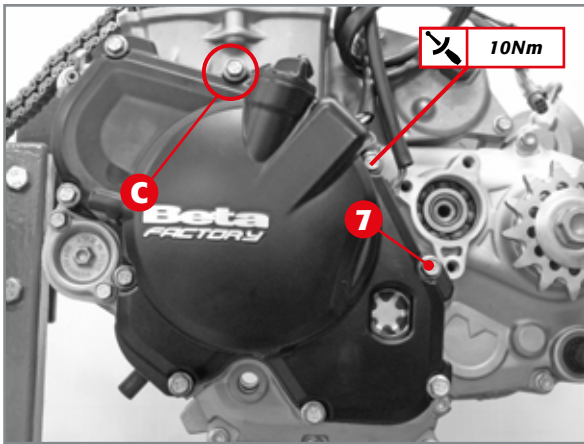

Grease the oil seal on the flywheel cover and couple it to the left crankcase with the nine M6x25 screws **7**.

Notice that a copper washer (12x6.3x1) **C** must be applied to the screw.

Tighten the screws at a torque of 10Nm.

Flywheel cover coupled to crankcase.

3.17 THERMAL UNIT

Before assembling the thermal unit, thorough controls must be carried out on the cylinder, piston, pin bolt, piston rings, cylinder head and the timing unit described hereafter.

3.17.1 CHECKING THE PISTON, PIN BOLT AND PISTON RINGS

Eliminate carbonaceous sediment from the top of the piston and wash the entire piston with specific degreasing agent.

Do not use sharp points or tools for cleaning.

Then carry out a careful analysis of the piston which must be free from forcing, scratches, cracks or any type of damage.

Analyse the outside diameter of the piston whose service limit is carried in the table below concerning their specific class. The diameter must be measured at a distance X from the inner edge of the skirt, perpendicularly to the axis of the pin bolt.



Quota at which to measure the outside diameter of the piston.

Displacement [cm ³]	Quota X [mm]	Service limits based on relevant class [mm]	
		1	2
350	6	87.92	87.93
390	6	87.92	87.93
430	6	94.92	94.93
480	5.5	99.92	99.93

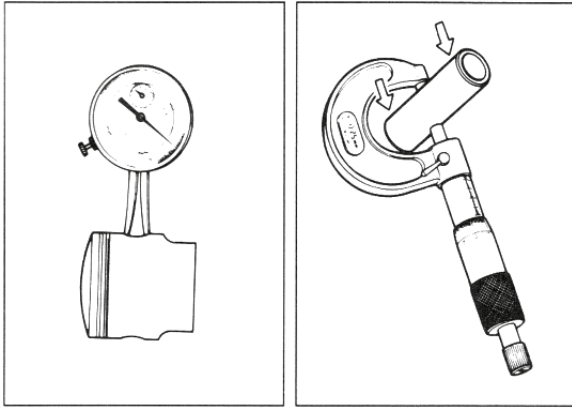

Measurement of pin bolt seat and pin bolt.



Elastic band wear limit check.

Check the size of the pin bolt seat located on the piston and the size of the pin bolt. This last control must be made at the end of the pin bolt itself in the area where it is engaged with the piston.

Displacement [cm³]	Size limit [mm]	
	Pin bolt seat	Pin bolt
350 -390	18.04	17.98
430-480	19.04	18.98

See the relative chapter regarding crankshaft and connecting rod controls for controls on connecting rod foot (par. 2.2).

In order to check the state of use of the piston ring and oil-scraper ring, the ring must be inserted in the cylinder so that its axis is aligned with the axis of the cylinder. Then measure the distance between the two opposite edges.

The respective service limits are carried in the table below.

Displace- ment [cm³]	Service limit of elastic band [mm]	Service limits of upper and lower oil- scraper ring [mm]
350-390	0.8	1.0
430-480		

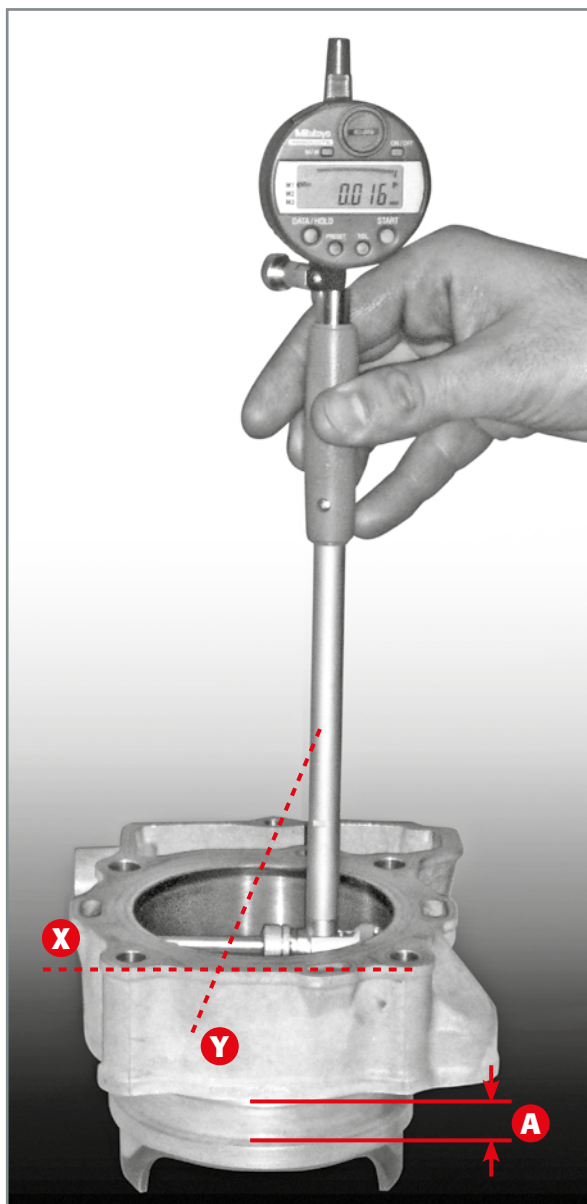

3.17.2 CYLINDER CHECK

Make sure the bore is within the service limits of the relevant class carried in the table below. Carry out measurement at a distance **A** from the top of the cylinder (surface between cylinder and cylinder head). To measure it correctly, it must be done according to the **X** and **Y** directions orthogonal between them. Consider the maximum measurement to determine the cylinder wear.

The difference between the two measurements is the ovalization.

This measurement must be carried out by placing the bore meter in such a way that its axis is perpendicular to the axis of the crankshaft.

Displacement [cm ³]	Quota A [mm]	Service limits based on relevant class [mm]		
		1	2	Ovalization [mm]
350	30	88.022	88.034	0.015
390	30	88.022	88.034	0.015
430	30	95.022	95.034	0.015
480	30	100.022	100.034	0.015

3.17.2.1 Coupling play

The following table carries the coupling play between the cylinder and piston.

In order to calculate the coupling play between the cylinder and the piston, a subtraction must be carried out between the diameter of the cylinder and that of the piston.

Displacement [cm ³]	Coupling play based on relevant class [mm]				Coupling play limit based on relevant class [mm]	
	Class 1		Class 2		Class 1	Class 2
	Min	Max	Min	Max		
350	0.035	0.057	0.037	0.060	0.10	0.10
390	0.035	0.057	0.037	0.060	0.10	0.10
430	0.035	0.057	0.037	0.060	0.10	0.10
480	0.045	0.067	0.047	0.070	0.12	0.12



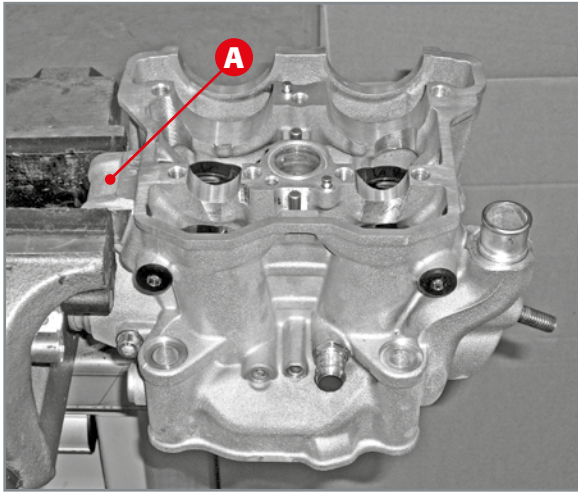

Blocking cylinder head on vice.

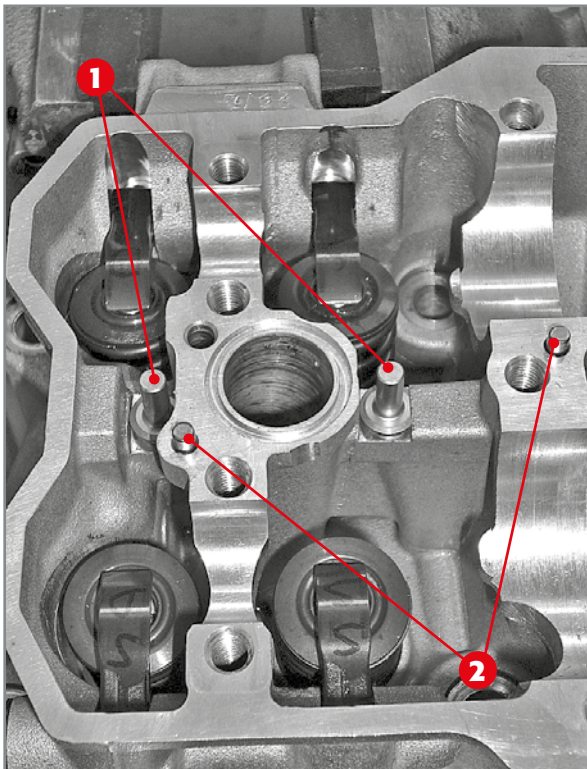

The oil jets 1 for the lubrication of the cylinder head and the two centring pins 2.

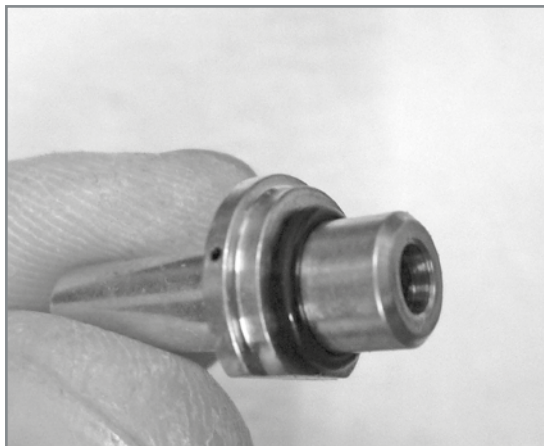

Detail of the lubrication oil jet 1.

3.17.3 CYLINDER HEAD: DISASSEMBLING AND CHECKING AUXILIARY DEVICES

Before disassembling the cylinder head, clean the entire unit thoroughly. The various elements must be cleaned and named bit by bit as they are disassembled. Proceed as follows for disassembly and inspection of the cylinder head. Clamp the cylinder head using protective jaws, gripping it at the head connection **A**. Disassemble the spark plug using the special spark plug wrench (code 020440100 000).

3.17.3.1 Lubrication jets and centring pins

Pull out the two oil jets **1** for lubricating the cylinder head and make sure the holes are free from any impurity. Take off the O-rings- If damaged, replace them.

Pay attention to the two centring pins **2**.

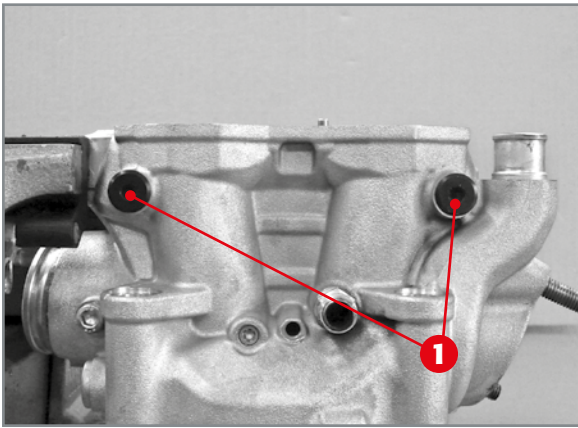

Closing caps for rocker arm support shaft seats.

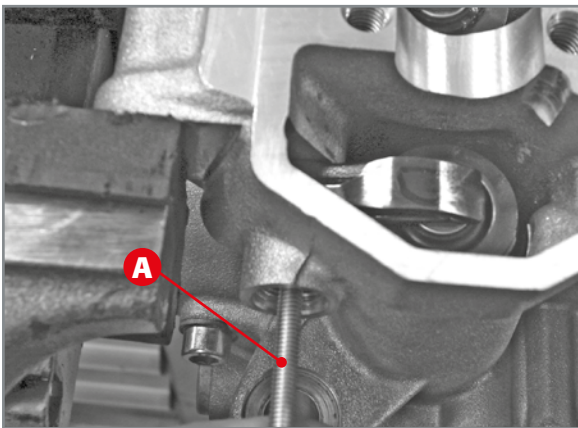

Application of M4 screw to allow the removal of the rocker arm support shafts.

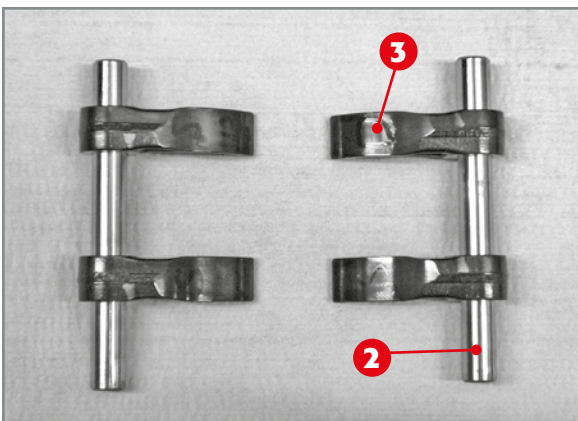

Rocker arm/shafts unit.

3.17.3.2 Rocker arm/shafts unit

Disassemble the two caps **1** which keep the rocker arm pins in place.

Make sure the face of the cap facing the shaft does not have deep traces or signs of wear. If so, replace the caps.

Check the state of use of the two O-rings between the caps and the cylinder head.

The rocker arm pins have a threaded hole (M4) at the end so that they can be extracted. To pull them out, just screw a sufficiently long M4 screw **A** in this hole and pull out. In this way, the rocker arms can be extracted.

Make sure the outside diameters of the pins **2** and the inside diameters of the holes on the rocker arms **3** respect the following service limits:

Shaft service limit: 6.98mm
rocker arm service limit: 7.03mm
Play limit: 0.05mm

Check to see that the contact areas between the rocker arm and the calibrated discs, and between the rocker arm and the cams are not chipped or particularly worn. If so, replace the rocker arm.

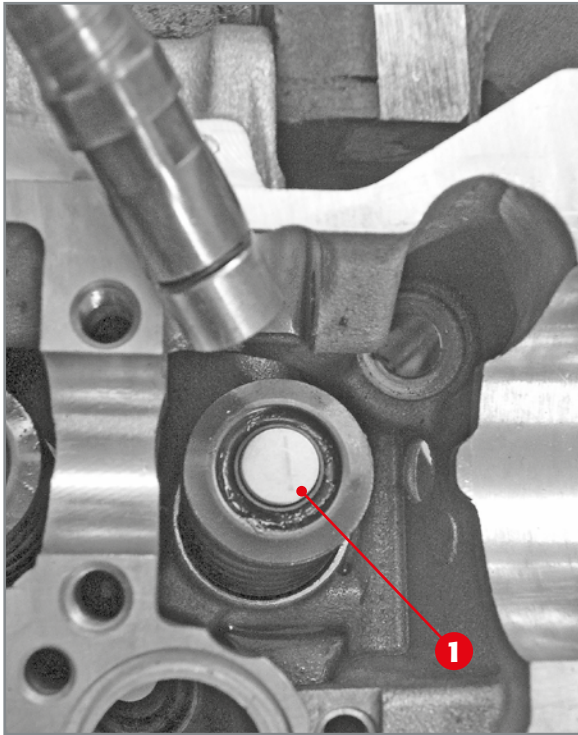

Removal of calibrated discs from seats.

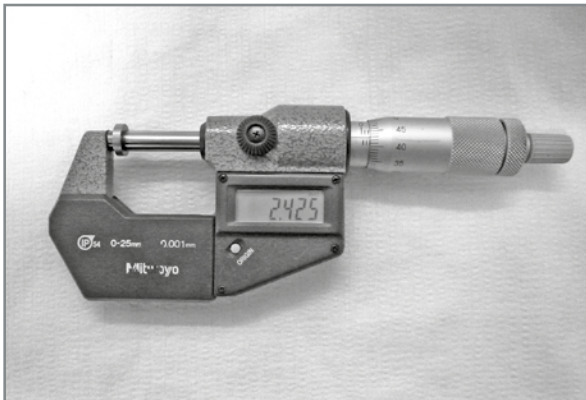

Calibrated discs measured with a (digital) thickness gauge.

3.17.3.3 Calibrated discs for valve play adjustment

Using a magnet, pull out the calibrated discs **1** from the seats in the cups.

Once the calibrated discs are extracted, measure them with a thickness gauge.

The calibrated discs range from 2.00mm to 3.200 according to the intervals carried in the table below.

Interval thickness[mm]	Step [mm]
2.000 ÷ 2.300	0.050
2.325 ÷ 3.000	0.025
3.050 ÷ 3.200	0.050

Once you have done the measurement, take note and mark the calibrated disc depending on its original position.

Should the calibrated discs be deteriorated, replace them with others having the same dimensions. Thus you can know whether to replace it with a thicker or thinner calibrated disc when determining the valve play.

3.17.4 CYLINDER HEAD: DISASSEMBLING AND CHECKING VALVE UNITS

Clamp the spring removal/assembly jaw **A** (code 0100043 000) and apply the spring removal/assembly tool onto it **B** (code 006140030 000). Then position the cylinder head and disassemble the springs.

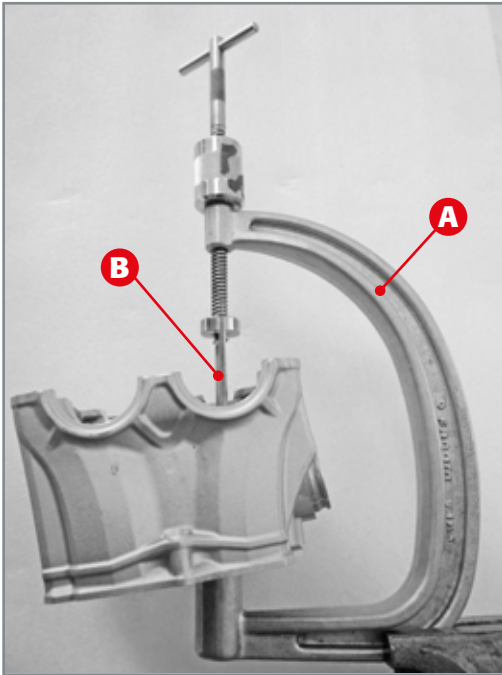

Positioning of cylinder head on device for valve spring disassembly.

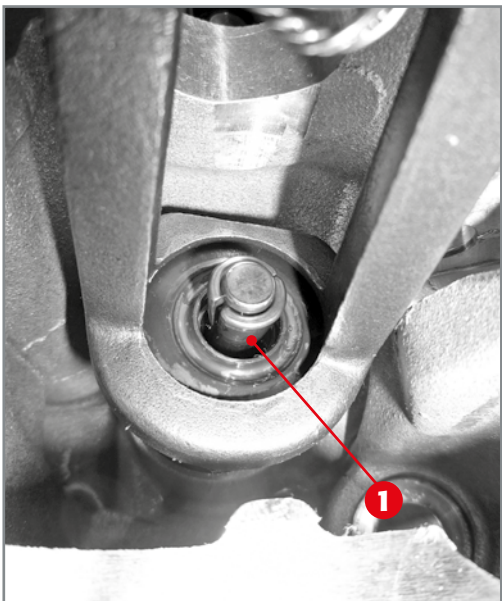

Extraction of half-cones.

Compress the spring as much as necessary to extract the half-cones **1**.

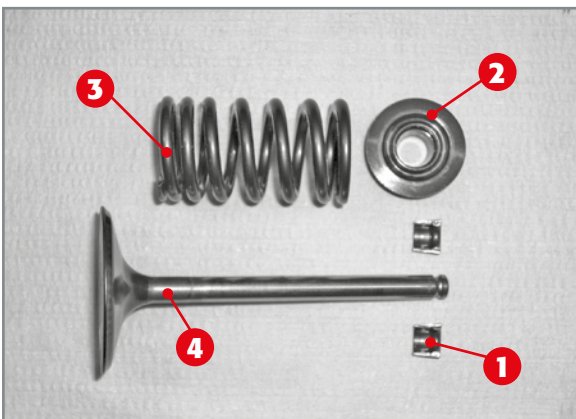

Valve unit.

After extracting the half-cones, release the spring and extract the cup **2**, the spring **3** and the valve **4**.

ATTENTION! Mark all the pieces you disassemble. Pay particular attention to the valves.



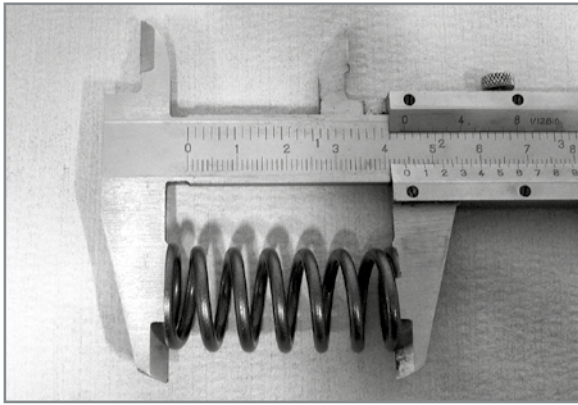

Measuring length of free spring.

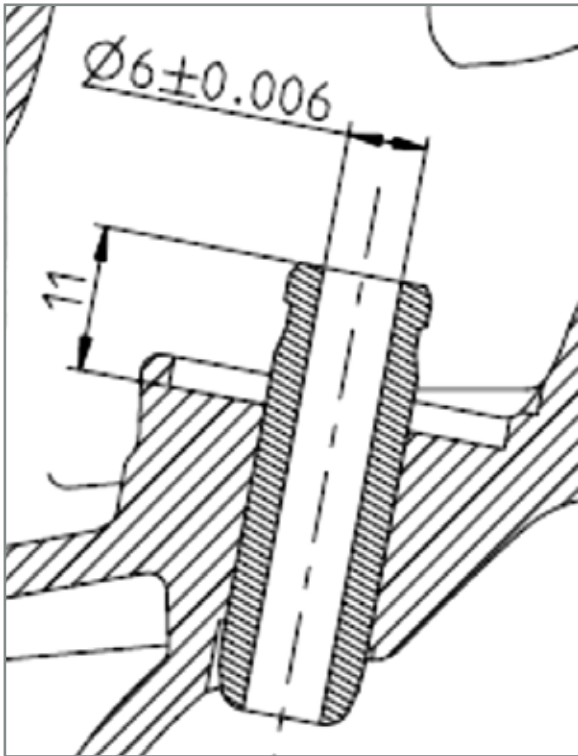

Reference dimensions for processing and fitting the valve guide.

3.17.4.1 Springs

Each valve is retained by a spring. The length of these springs must be checked while they are loose:

service limit = 42 mm

Should the springs be shorter, have them replaced.

3.17.4.2 Valve guides, valves and seats

Make sure that the valve guides are free from scratches or any type of nicks. To check the correct diameter, introduce the gauge in the valve guides from the side of the combustion chamber code 006140180 000. If the gauge can enter, the valve guide must be replaced at a rectification workshop. To this purpose, keep to the data carried in the drawing.

Remember that if replacing the valve guides, the seats of the valves must be repossed as described later on.

Brush the valve mushroom head thoroughly and degrease the entire valve.

Make sure that the valve stems are free from scratches or any type of nicks. Measure the diameter of the valve stems, making sure it is not less than the service limit:

Valve stem diameter service limit: 5.95mm

If it is, replace the valve.

Play between the valve and the valve guide must not be greater than the limit carried below:

**Play limit between valve and valve guide:
0.08mm**

Check that the valve mushroom and seat contact area is not dented: if so, replace the valve.

Check the state of wear of the valve seats and the sealing surface. In order to do this, apply a light layer of Prussian blue paint on the contact zone of the valve with the seat. Then insert the guide valve until you press it against the seat and turn it on its own axis.

Taking the valve out, the paint will be missing in the contact zone. Its width must not be greater than the following service limit:

Width service limit of valve seat contact zone: 1.9 mm.

The contact zone can principally take on three different appearances, as shown in the figure:

- A** - correct;
- B** - incorrect (contact face damaged);
- C** - incorrect (uneven seat width)

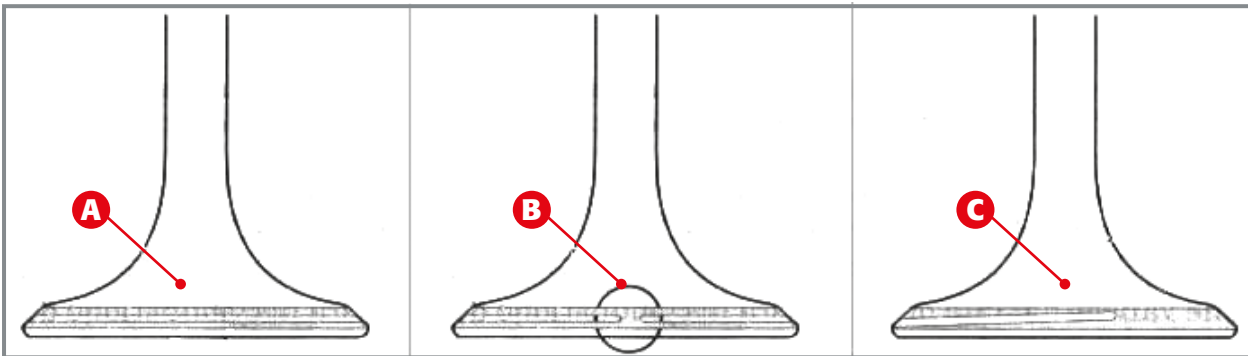

Valve-seat contact conditions: A) Correct; B) Incorrect - contact face damaged-; C) Incorrect - uneven width.

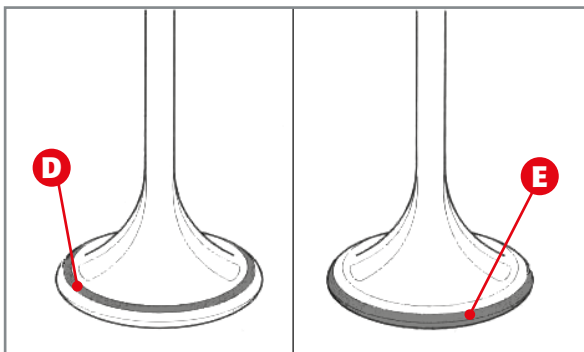

Positioning of contact area: D) too high; E) too low.

Also check the correct positioning of the contact area. It must be neither higher (case D) or lower (case E).

Should the incorrect conditions described above occur, the valve seats must be rectified, respecting the conditions carried in the following drawing.

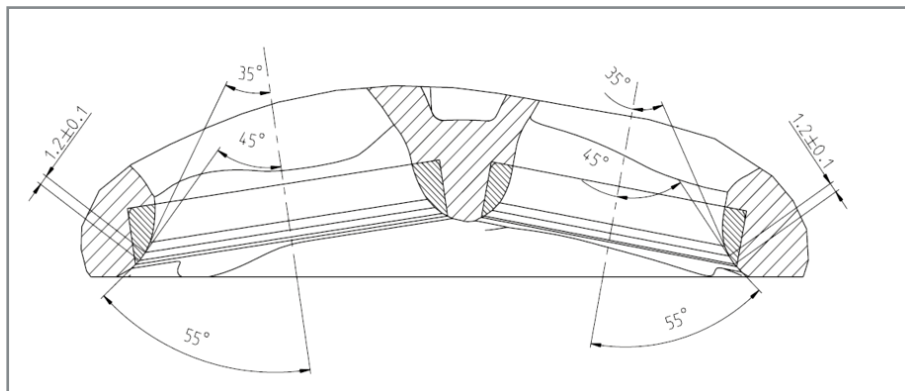

Taking the valve out, the paint will be missing in the contact zone.

If the valve seats are beyond recovery, replace the cylinder head.



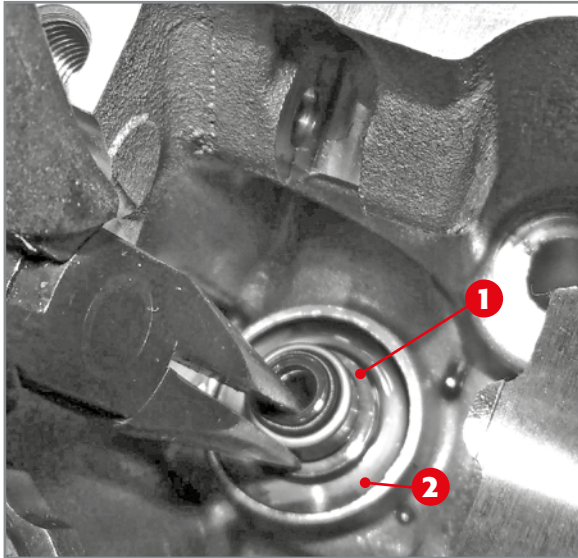

Removal of valve stem oil scraper rings.

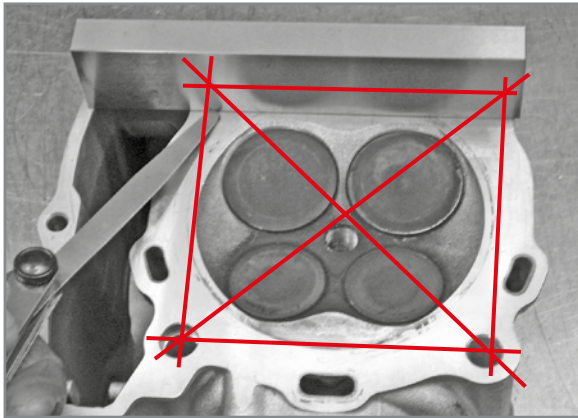

Reference dimensions for processing and fitting

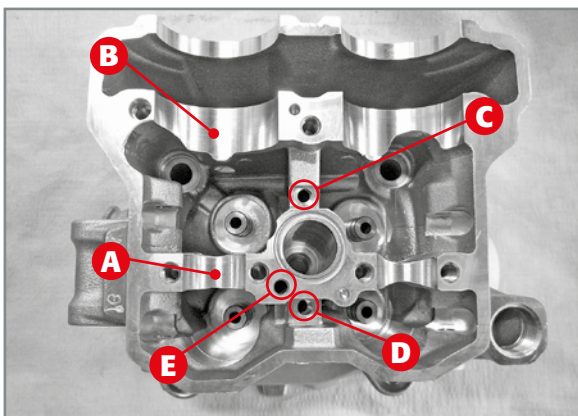

3.17.4.3 Oil-scraper rings and lower cup

Should there be excessive oil consumption or a white-like exhaust smoke which cannot be blamed on the oil-scraper bands on the piston, replace the oil-scraper rings **1**, intended to prevent excess oil leakage.

It is recommended to replace them every time the cylinder head is overhauled.

In order to replace them, use needle-nose pliers to pull them out, being careful not to nick the valve guide.

Once the oil-scraper ring is extracted, the lower cup can be pulled out **2**.

3.17.5 CYLINDER HEAD: CHECKING THE CYLINDER HEAD BODY

Check the flatness between the head and cylinder coupling surfaces.

This can be done using a rectified block and a thickness gauge by positioning the block according to the directions shown in the figure.

The service limit is:

cylinder head service limit: 0.05mm

Check that the state of use of the sliding zones **A** with the camshafts and **B** of the camshaft support bearing housing are free of scratches or signs of meshing.

Clean the oil passages for lubricating the cylinder head by blowing compressed air into the holes **C**, **D** and **E**.

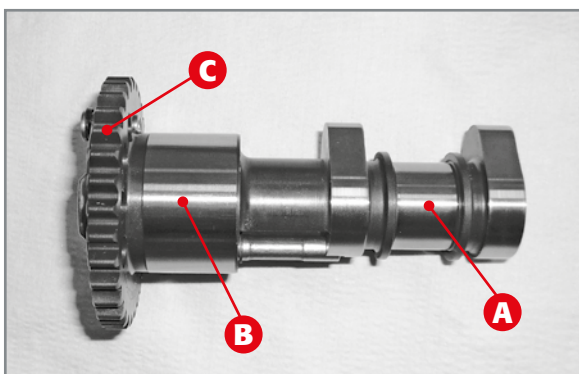

Cam zone to be checked.

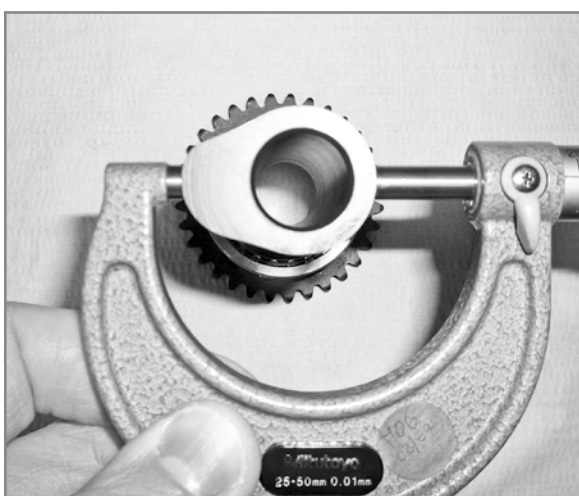

Cam height measurement.

3.17.6 CHECKING CAMSHAFTS

Verify the zones **A** and **B** on the camshafts making sure they have no traces of meshing or abnormal wear. Make sure the sides of the teeth **C** are not chipped or have no trace of abnormal wear.

The zone **A** comes into contact with the cylinder head becoming part of a hydrodynamic support bearing. Zone **B** on the other hand supports the roller bearing.

Make sure that the shafts in the cam zones are free of abnormal colouring which is typical when working without oil.

Use a thickness gauge to check the wear limit of the cams referring to the values carried in the table.

Sometimes the cams can be scratched and this can be accepted, provided that the profile is within the envisaged limits of wear.

Displacement [cm ³]	Intake		Exhaust	
	Nominal size [mm]	Size limit [mm]	Nominal size [mm]	Size limit [mm]
350 - 390	34.1	34.0	33.75	33.65
430	34.1	34.0	33.4	33.3
480	33.75	33.65	33.4	33.3

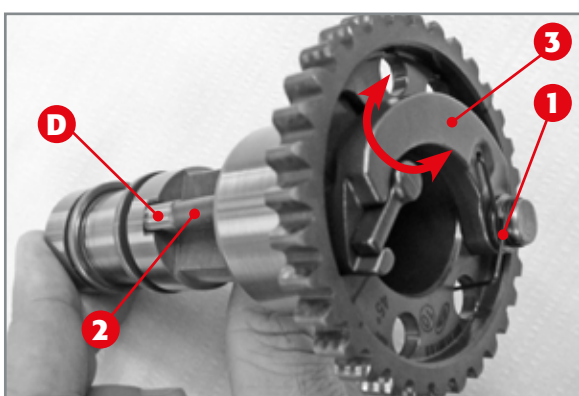

Check on the exhaust camshaft that the spring **1** of the centrifugal decompressor recalls the rest of the device so that the cylinder segment **D** of the rod **2** protrudes completely without any play.

Turn the lever **3** all the way to make sure the device is not jammed.

Make sure that the cylinder segment **D** of the decompressor is not worn or chipped.

Should it be deteriorated, replace the decompressor shaft.

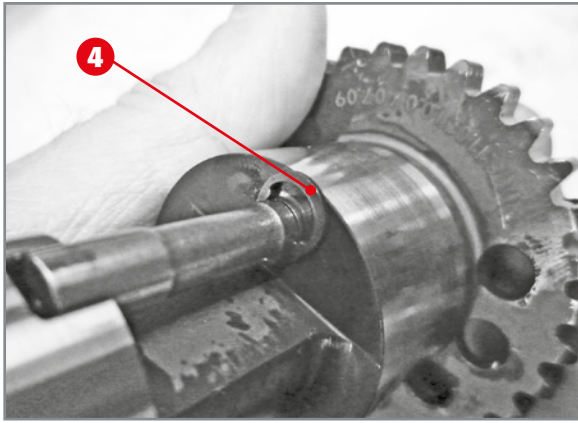

Extraction of Benzing ring from decompressor shaft.

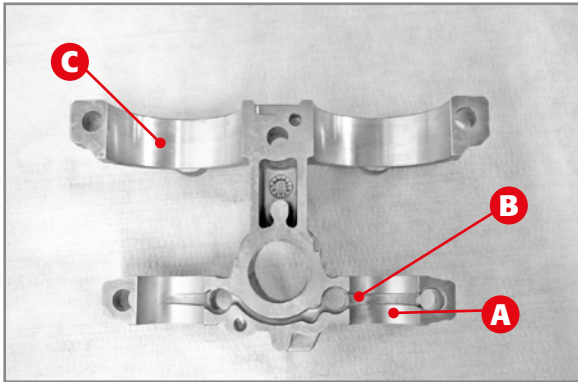

In order to extract it, remove the Benzing ring **4** and pull the shaft out. Operate inversely to reassemble it. When replacing the decompressor shaft, replace the Benzing ring as well.

3.17.7 CHECKING CAMSHAFTS SUPPORT

The camshafts supports fasten the shafts so they maintain the correct position while operating. The support in the zone **A** has a channel **B** intended to lubricate the camshaft to allow the hydrodynamic support of the shaft itself. Therefore you must make sure that the zones **A** are free from scratches or traces of corrosion.

Make sure the zones **C** for housing the roller bearings have no traces of meshing or scratches.

Attention: *if the support needs to be replaced, the cylinder head must be replaced as well.*

3.17.8 CYLINDER HEAD: INSERTION OF LOWER CUP AND OIL-SCRAPER RING

If the lower cups and oil-scraper rings were disassembled*, reassemble them as follows. First insert the lower cup **1** facing the flat part downwards. Lubricate the upper part of the valve guide lightly and insert the oil-scraper ring **2**. Pay close attention that while inserting the valve stem seal, its axis is aligned with that of the valve guide. The oil-scraper ring must be pressed towards the bottom of the cylinder head until it is flush with the valve guide.

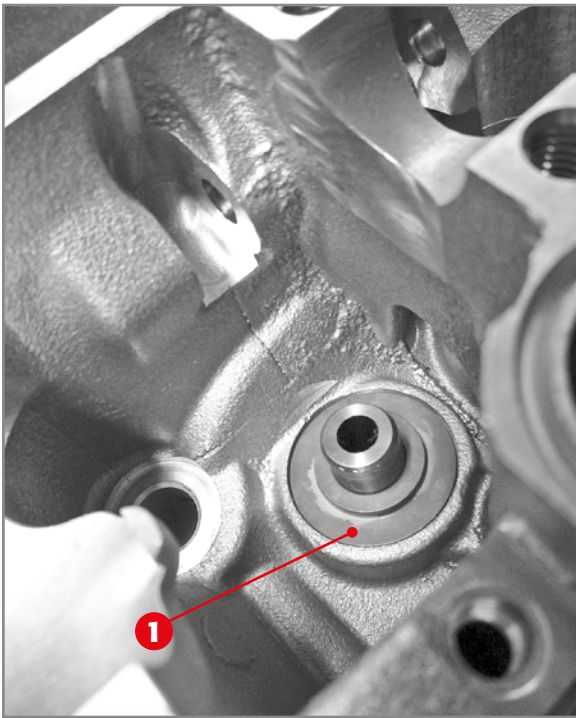

Insertion of lower cup.

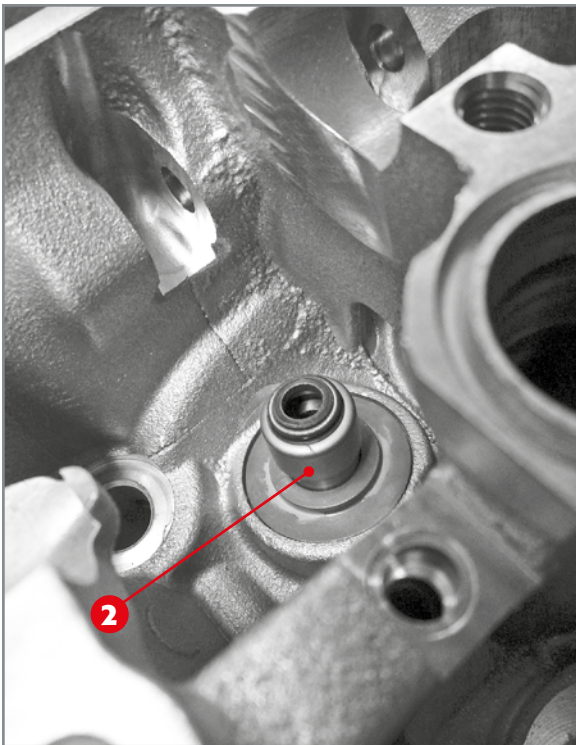

Insertion of oil-scraper ring.

Remember the valve stem seals must be replaced once they have been taken off.

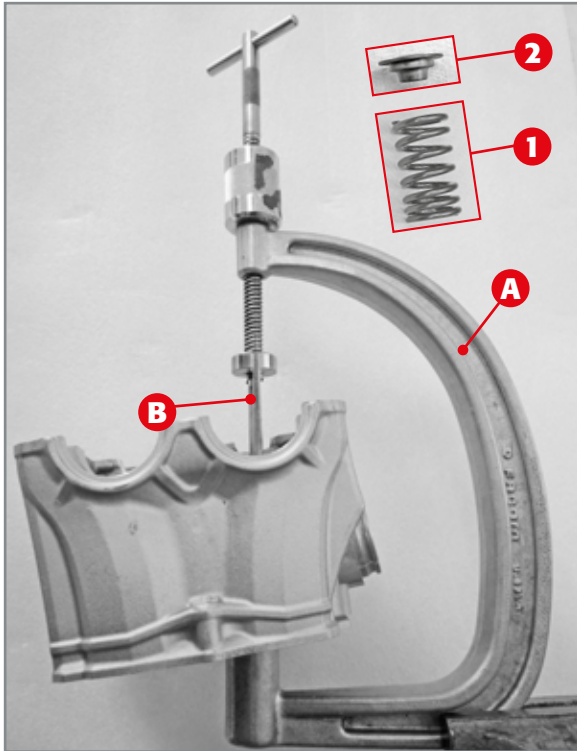

Positioning of cylinder head on device for valve spring disassembly/assembly.

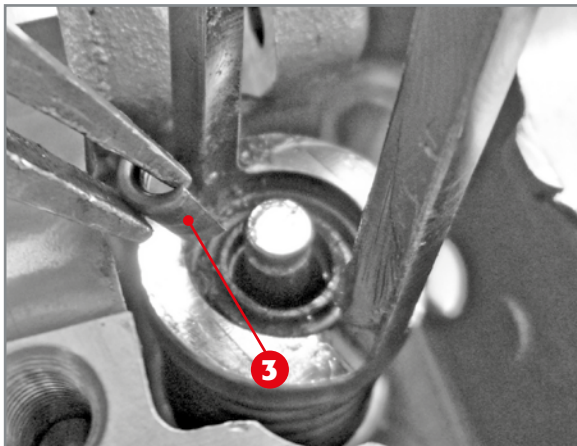

Spring compression, half-cones insertion. Insertion of valve stem seal.

3.17.9 CYLINDER HEAD: ASSEMBLY OF VALVE UNIT

Clamp the spring removal jaw **A** (code 0100043 000) and apply the spring removal/assembly tool onto it **B** (code 006140030 000).

Insert the valve stem in the valve guide* from the combustion chamber side.

Place the valve in the specific lower housing of the jaw and introduce:

- The spring **1**, being careful to insert it so that the segment with the smaller pitch faces downwards;
- The upper cup **2**, turning the flatter part upwards.

Compress the spring as much as necessary to extract the two half-cones **3**. To facilitate their insertion, apply a small amount of grease on the stem in the half-cone housing zone.

* If the valves, valves guides and their seats have not been replaced, the valves must be put back in their original positions.

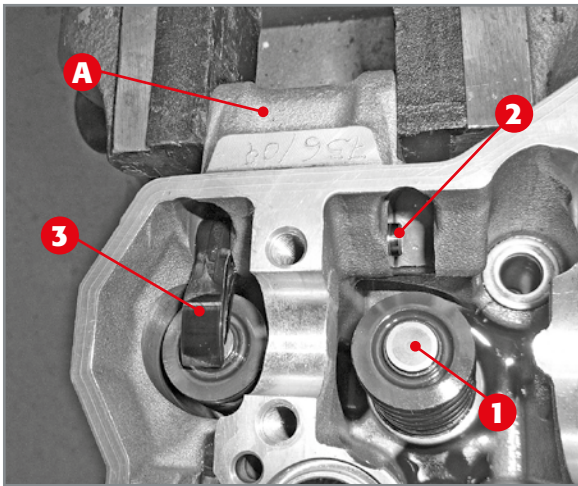

Insertion of pin 1 external rocker arm 2.

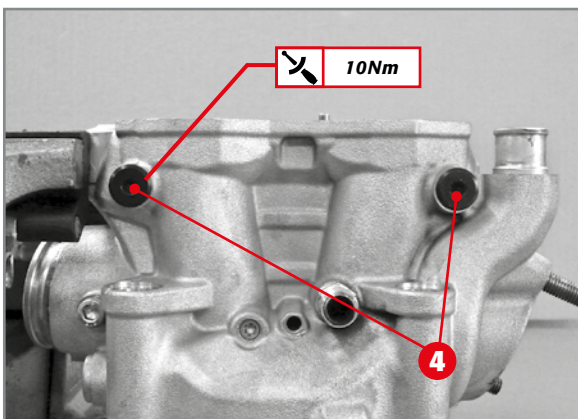

Application of two rocker arm pin caps.

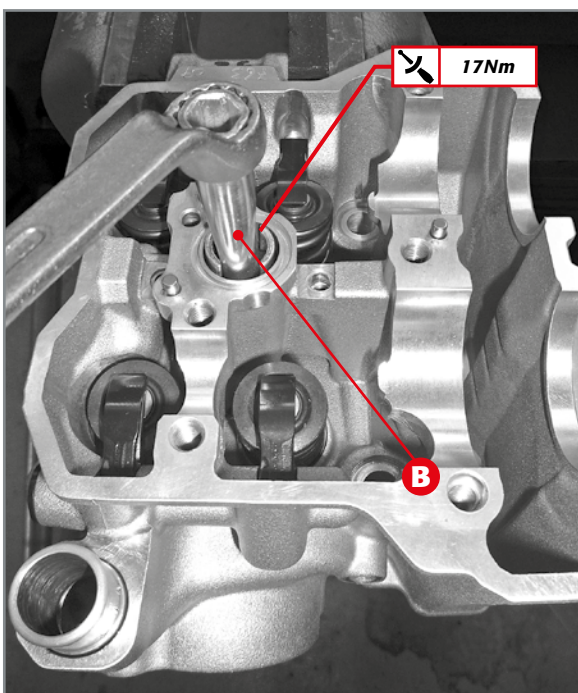

3.17.10 CYLINDER HEAD: REPOSITIONING CALIBRATED DISCS. ASSEMBLING ROCKER ARM PINS AND ROCKER ARMS AND COUPLING THE SPARK PLUG

Clamp the cylinder head using protective jaws, gripping it at the head connection **A**. Put the calibrated discs **1** back in place in their original positions (if not deteriorated see par. 2.17.3.3).

Insert the rocker arm shaft **2** partly in the specific seat as much as needed to be able to insert the outermost rocker arm into the cylinder head first **3**. Having fastened the outermost rocker arm to the shaft, push the shaft further until it reaches the seat of the innermost rocker arm. Having coupled the innermost rocker arm to the shaft push it all the way into the cylinder head.

Couple the two caps **4** with the O-rings to the cylinder head. They must be tightened to the indicated torque.

Apply the spark plug on the special wrench **B** (code 020440100 000), introduce the unit in the specific housing and tighten to the indicated torque.



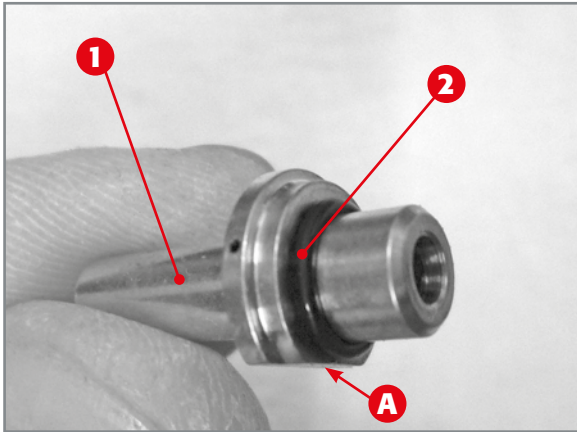

Oil jet with O-ring. Note flat reference area A on the side of the jet.

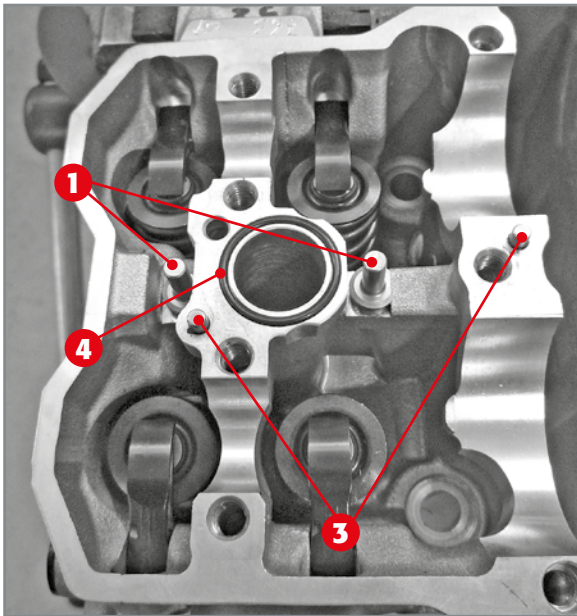

Overhead view of complete cylinder head.

3.17.11 CYLINDER HEAD: INSERTION OF OIL JETS, CENTRING PINS AND SPARK PLUG O-RING

Insert the oil jets **1** with the O-rings **2** in their specific seats on the cylinder head.

The positioning of the jets **A** is univocal thanks to the specific flat side.

If the centring pins **3** have been removed, put them back in place on the cylinder head. Apply the spark plug housing sealing O-ring **4** between the cylinder head and the camshaft support.



Application of the scraper ring strap, version 350cc-390cc.

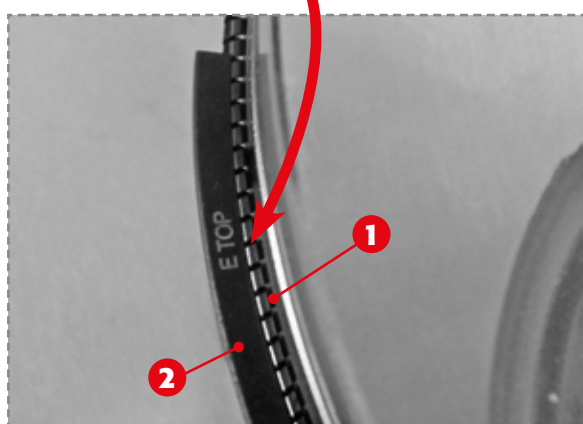

Picture showing positioning of the external scraper ring strap.

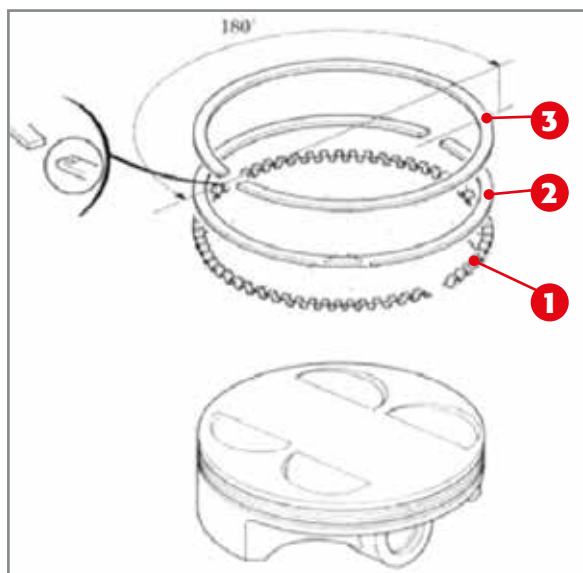

Application of piston segments.

3.17.12 PISTON: APPLICATION OF THE OIL-SCRAPER AND SEAL BANDS, APPLICATION OF THE SEEGER

3.17.12.1 Piston: application of the oil-scraper and seal bands, version 350cc-390cc

The indications in this paragraph refer to the vehicles listed in the table below:

Version	Model Year	up to no. VIN (included)
RR 350	2018	All
RR 390	2018	All
RR 350	2019	ZD3E615C0K0100723
RR 390	2019	ZD3E616C0K0200478

Lubricate the seats of the segments with plenty of oil and put the internal scraper ring strap **1** in the lower seat of the piston.

Lay the external scraper ring strap **2** on the internal one with the "TOP" marking facing the top of the piston.

Put the seal band **3** in the upper seat.

The oil-scraper ring and retaining straps must be laid so that their openings face the higher segment of the skirt and at 180° between them. The seal band **3** must be assembled with the reference (letter or number) facing upwards.



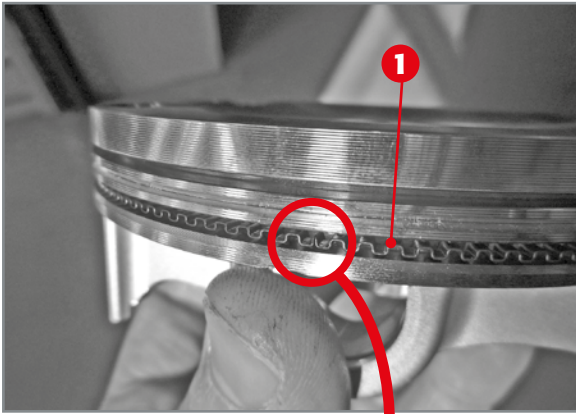

Application of the central oil-scraper band.

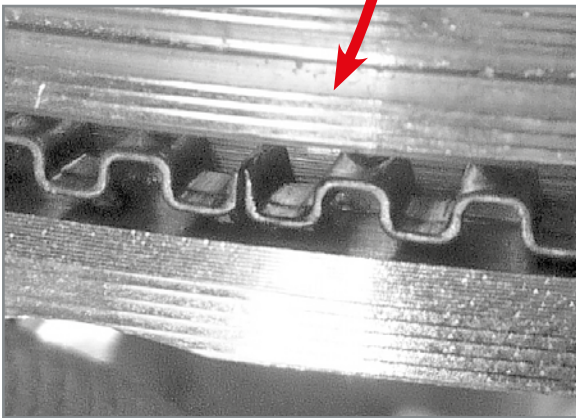

Detail of positioning of two edges.

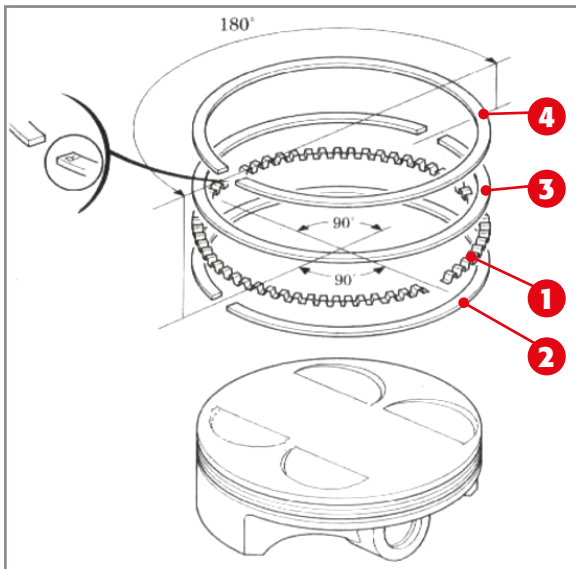

Application of piston segments.

3.17.12.2 Piston: application of the oil-scraper and seal bands

The indications in this paragraph refer to the vehicles listed in the table below:

Version/Model	Year (MY)	up to no. VIN (included)
RR 350	2019	ZD3E615C0K0100724
RR 390	2019	ZD3E616C0K0200479
RR 430	2018-2019	All
RR 480	2018-2019	All

Oil the segment seats abundantly and apply the central oil-scraper band in the lower seat of the piston **1** paying close attention that the two ends face one another but do NOT overlap.

The two ends must be aligned in axis with the pin bolt.

Apply the two lower **2** and upper oil-scraper rings **3** and then the seal band **4**.

The two oil-scraper rings must be placed so that their openings face the higher segment of the skirt and at 180° between them. Assembly of the seal band **4** must be done keeping the reference (letter or number) facing upwards and the opening must face the same way as the opening of the lower oil-scraper ring **2**.

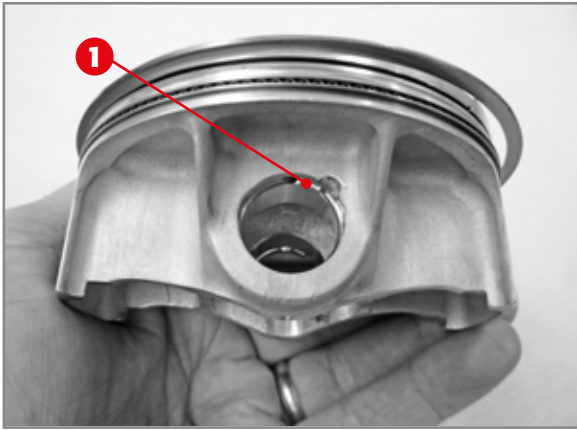

Application of circlip 1 to piston.

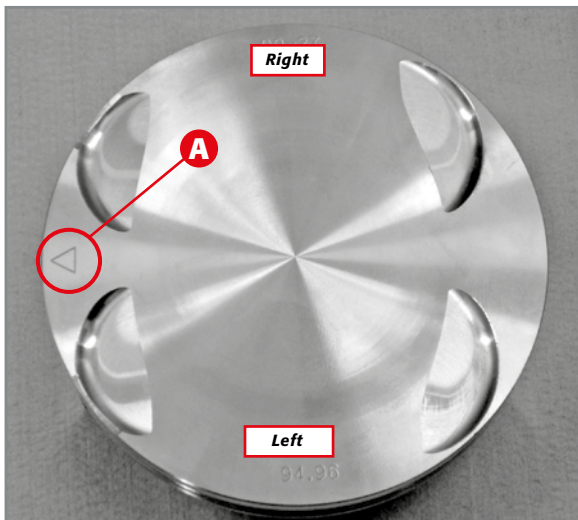

Identification of piston right and left side.

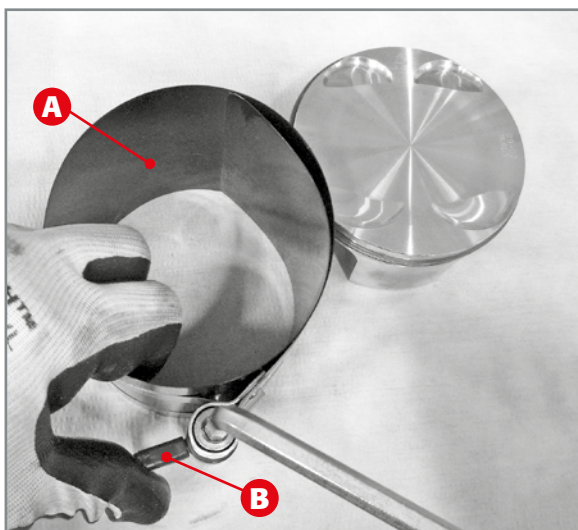

Preparation of elastic friction band A.

3.17.12.3 Piston: seeger application

Generously lubricate the seats for the pin bolt with motor oil and the circlip 1 in the left pin bolt seat, being careful to position it so that the lug on the circlip inserts itself in the specific seat on the piston.

In order to identify the right and left side of the piston, just use as a reference the arrow **A** stamped on the piston crown which must face the exhaust manifold.

3.17.13 APPLICATION OF PISTON TO CYLINDER

To couple the piston to the cylinder, place the cylinder while keeping the top facing upwards. Oil the cylinder with plenty of motor oil. Prepare the elastic friction band **A** (code 006140170000) as shown in the figure. Press the green locking lever **B** and turn the hex key anti-clockwise until the band reaches a dimension near that of the piston. Oil the inside of the band abundantly and insert the piston with all its rings inside of it. Press the green locking lever again and turn the hex key clockwise to tighten the segments and piston well.

Attention: the elastic band has edges which could be sharp. Be very careful when handling it.

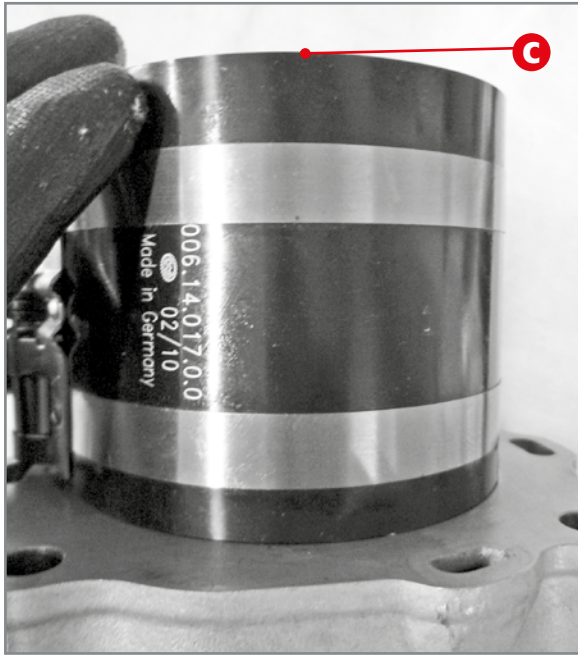

Application of the complete piston band on cylinder.

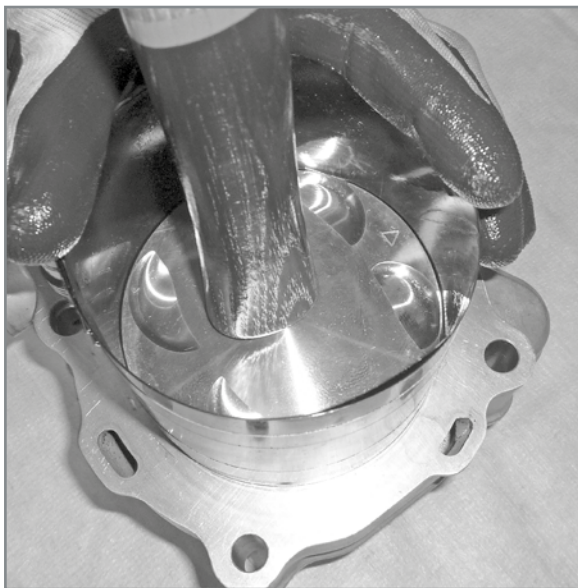

Insertion of piston into the cylinder.

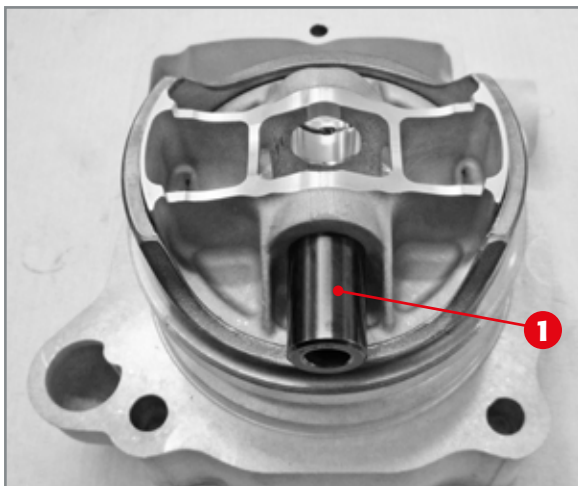

Application of pin bolt to piston.

Press the piston downwards having the higher segment of the skirt protrude a bit from the band. Rest the unit on the cylinder, making sure that the contact zones of the band rest correctly on the cylinder surface. For this purpose, make sure that the upper edge **C** of the band is perfectly aligned with the contact surface of the cylinder.

Note: When positioning the complete band-piston unit on the cylinder, be careful to place them so that the arrow stamped on the crown of the piston faces the exhaust manifold.

Holding the band firm with one hand, push the piston inside the cylinder, making sure that the axis of the piston is aligned with that of the cylinder. Towards the end of insertion it might be necessary to use the wooden handle of a hammer or a similar tool to lightly tap the piston crown in order to facilitate its complete insertion in the cylinder.

Attention: during the whole operation, hold the band firm with one hand without moving it. Make sure that the segments insert themselves correctly in the cylinder when passing through the band. Should there be excessive resistance when inserting the piston into the cylinder, do not insist in order not to deteriorate the parts: assess the cause.

When the piston has been inserted into the cylinder and the band has been removed, press the piston towards the bottom of the cylinder so that the pin bolt seats come out from the lower edge. Apply the pin bolt **1** into the right-hand seat as much as needed to allow it to be coupled with the connecting rod.

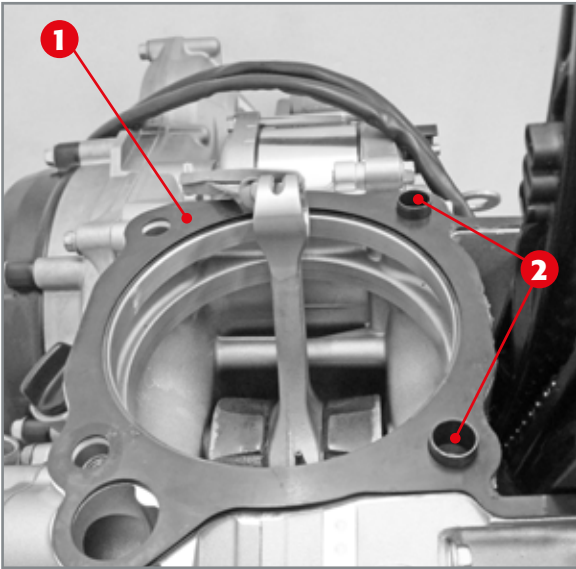

Application of cylinder/crankcase gasket and of centring bushes.



Passage of chain in cylinder.

3.17.14 APPLICATION OF PISTON-CYLINDER COUPLING TO CRANKCASE

Apply a new piston-cylinder gasket **1** to the crankcase and couple the two centring bushes to the left crankcase **2**. Lubricate the foot of the connecting rod abundantly with motor oil.

Insert the timing chain in the proper compartment in the cylinder and bring the piston/cylinder unit close to the connecting rod. Once the pin bolt reaches its housing in the foot of the connecting rod, push the pin bolt inside until it is inserted all the way. It may be helpful to use an aluminium cylinder (or similar tool) during this phase.

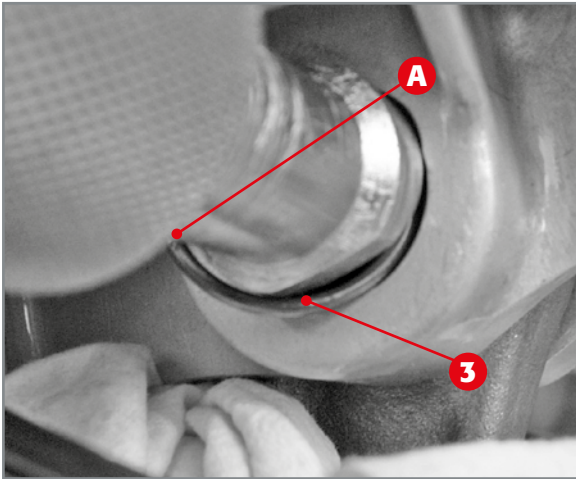

Circlip insertion.

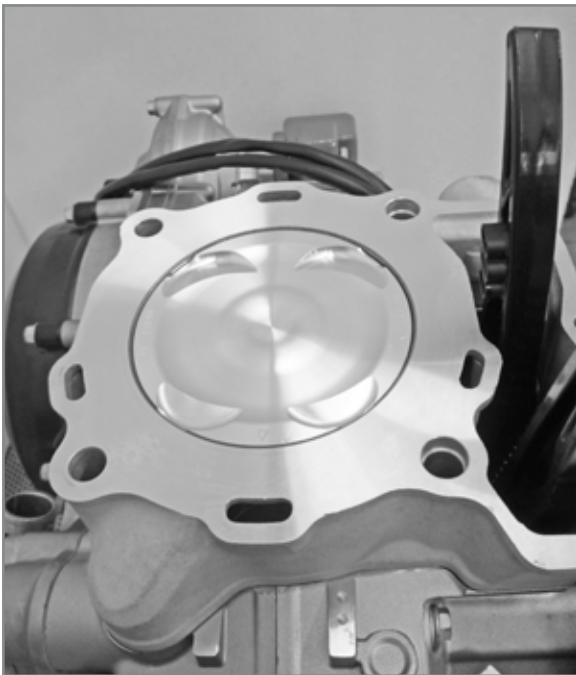

Coupling cylinder to crankcase.

Apply the lug to the circlip **3** in the pin bolt seat. Insert the cylindrical part of the special tool **A** into the pin bolt and, having one of the two flat surfaces of the tool coincide with the part of the circlip to be inserted, turn and push the special tool towards the engine until the circlip is fully inserted into a seat.

Push the cylinder towards the crankcase making sure the two centring bushes on the left crankcase are correctly inserted in the seats in the lower part of the cylinder.

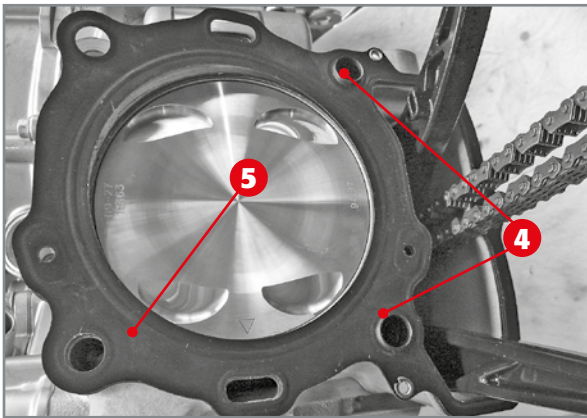

Application of guide bushes 4 and gasket 5 to cylinder.

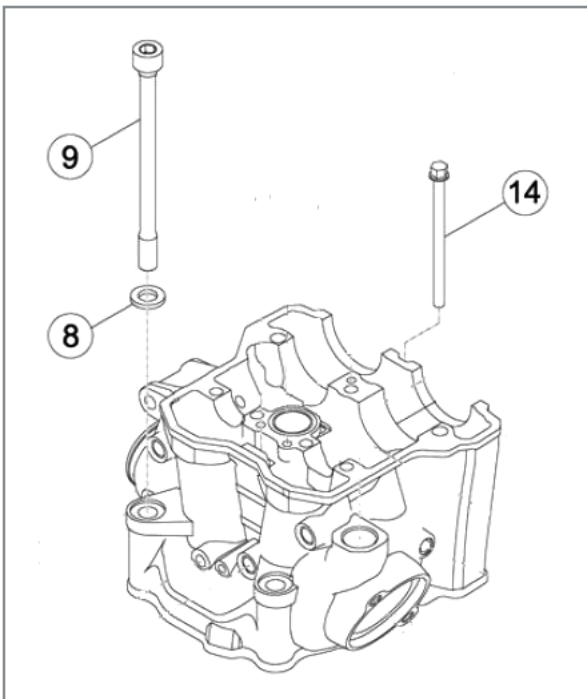

Application of components for coupling the head and cylinder to crankcase.

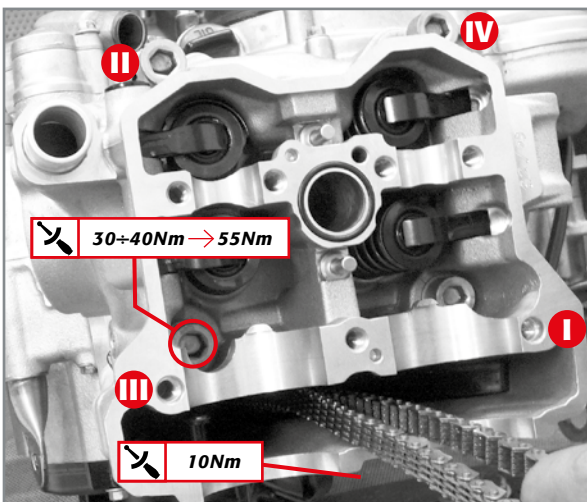

Tightening order of screws coupling the head and cylinder to crankcase.

Apply to the cylinder the two guide bushes 4 and the gasket 5 coupling with the cylinder head.

3.17.15 COUPLING HEAD TO CYLINDER

Introduce the timing chain in the compartment on the cylinder head. Keeping the chain tight, place the head on the gasket making sure it inserts perfectly into the two centring bushes on the cylinder.

Lubricate the four washers 8 and insert them into their specific seats on the outside and inside of the cylinder head. Then insert the four M10x1.25 screws 9 - after having lubricated them- and the M6x80 screw 14 which connect the head and cylinder to the crankcase.

Tighten the four screws in two stages following a criss-cross pattern and starting with one of the two screws inside the head.

The first tightening can be done at 30+40Nm, while the second and last one is fixed at 55Nm. The screw 14 must be tightened to the indicated torque. Keep the chain lifted so that it does not fall inside the chain compartment.



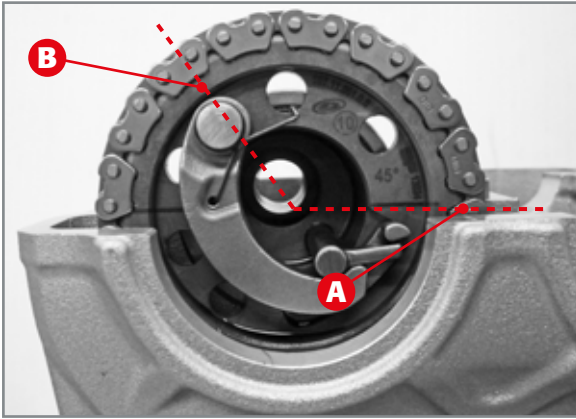

Positioning camshaft.

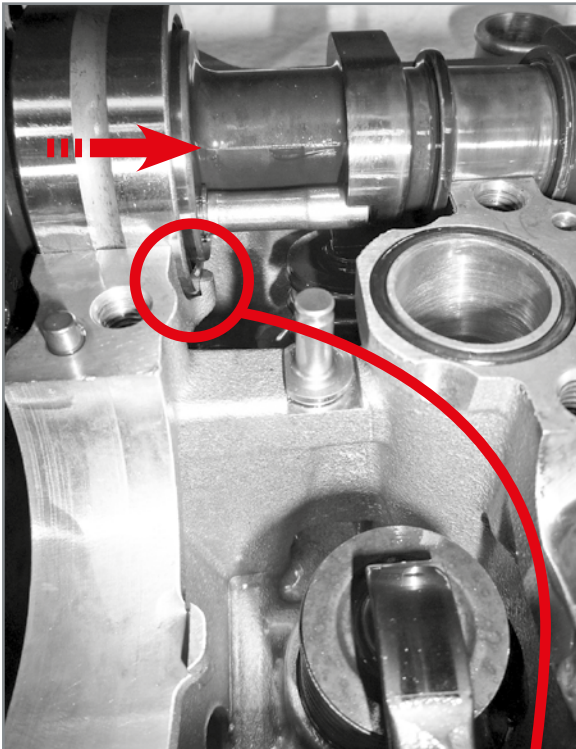

Positioning camshaft bearing.

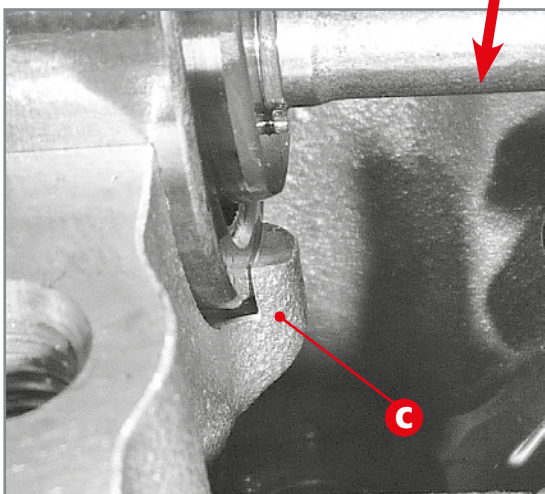

Detail of positioning bearing against shoulder C.

3.17.16 COUPLING CAMSHAFTS TO CYLINDER HEAD AND PHASING

Couple the bearings to the camshafts and lubricate them with motor oil.

Widening the timing chain, insert the exhaust camshaft upon whose gearwheel the timing chain must be placed. It is advisable already in this phase to position the shaft so that the reference notches **A** are horizontal with the cams facing upwards according to the approximate direction **B**.

Lift the camshaft slightly and move the bearing so that it is flush with the shoulder **C**.

Having carried out the above-mentioned positioning, rest the camshaft on the cylinder head.

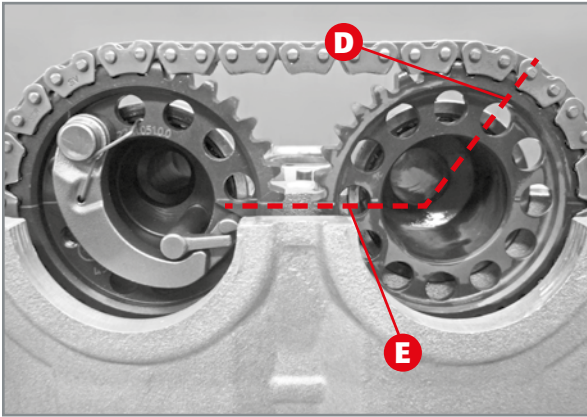

Application of components for coupling cylinder head.

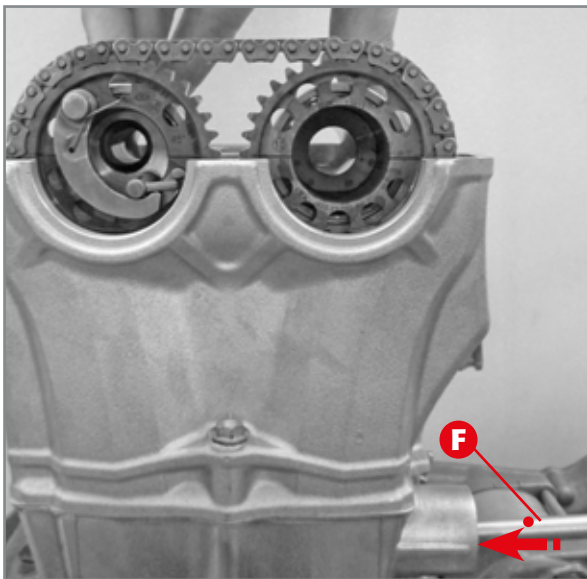

Phasing check. Note the pressure that the cylinder F exerts on the chain.

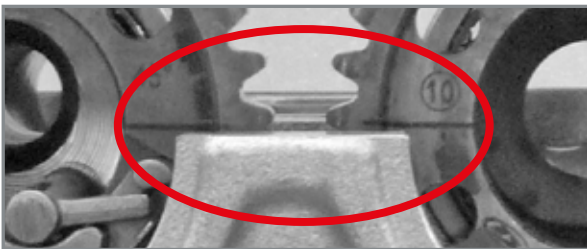

Detail of correct alignment of engraved notches on gearwheels of camshafts.

Lift the chain again and insert the intake camshaft placing the chain on the gearwheel. Place the shaft so that the cams face upwards according to the approximate direction **D** and the references **E** carved on the gear are horizontal. Position the bearing in the same way as for the exhaust camshaft.

Holding the camshaft still with one hand, insert an aluminium cylinder **F** in the housing of the hydraulic tensioner as far as needed to be able to push the movable guide against the timing chain. Make sure that the notches engraved on the two wheels are aligned one with the other. If so, the phasing is correct. If not, release the cylinder **F**, lift the timing chain so that the gearwheels disengage allowing the needed rotation to obtain correct phasing. Having checked phasing, extract the cylinder **F**.



Lubricate the entire camshaft unit with motor oil and apply the support **1**, making sure it is perfectly engaged both on the shafts and on the centring pins.

Note:
check the presence of the oil jets (par. 1.17.11).

Apply the fixed pad **2** and insert the three M7x38 screws **3** in the holes on the chain side and the four M7x33 screws **4** in the four remaining holes.

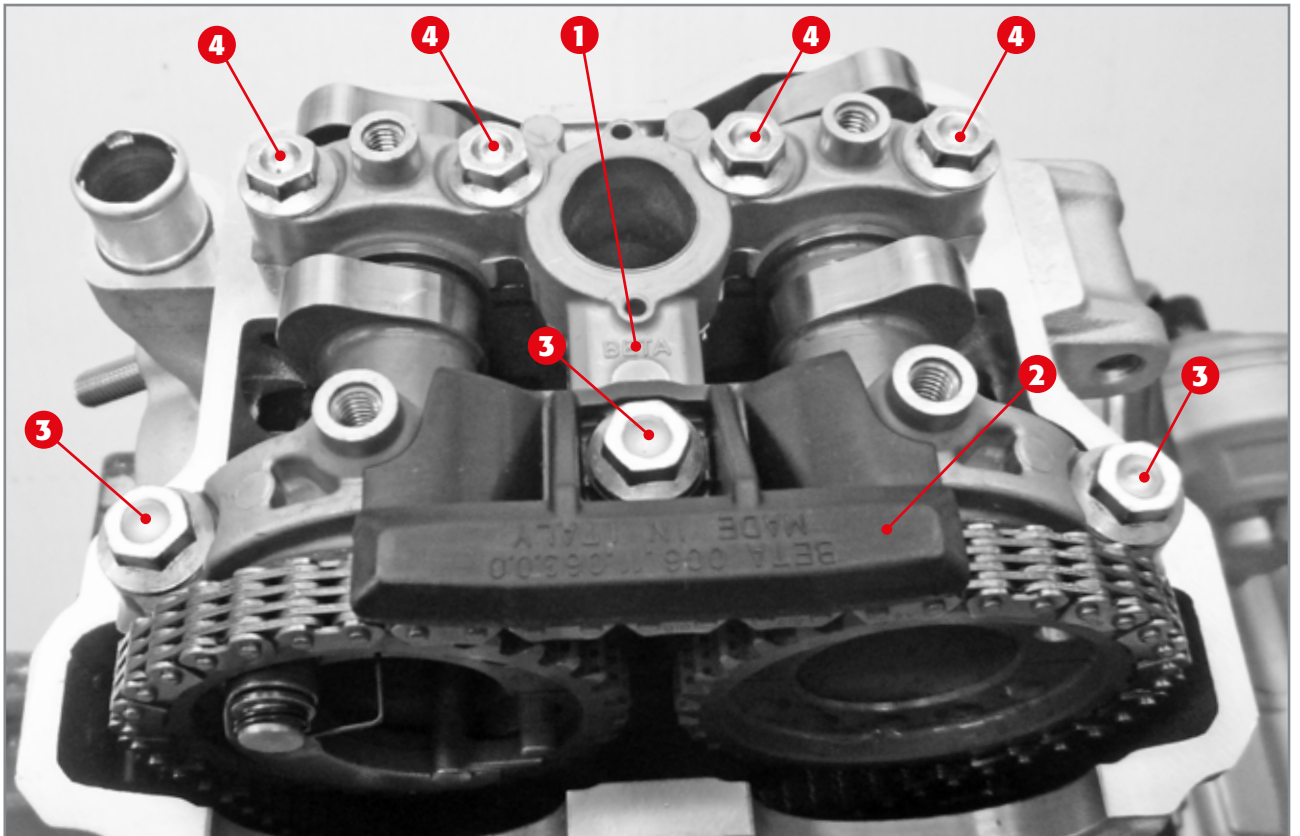

Application of camshaft support **1**, chain guide **2**, three M7x38 screws **3** and four M7x33 screws **4**.

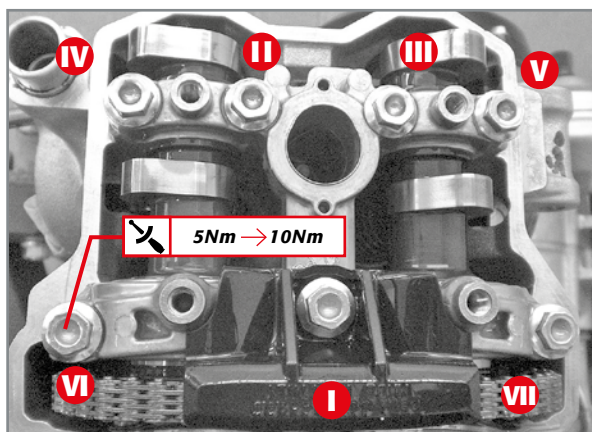

Tightening order of camshaft support screws.

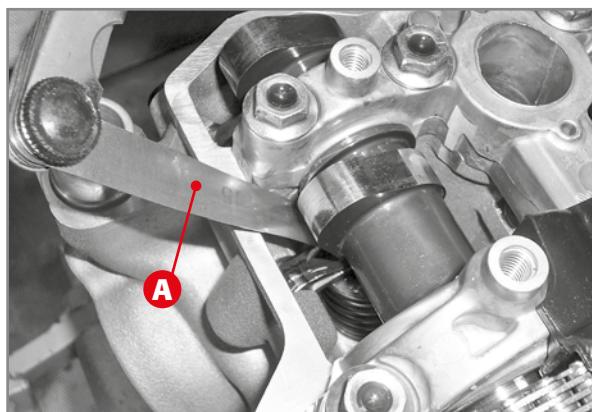

Checking valve play with thickness gauge.

Tighten the seven screws by hand until they are flush.

Check the correct position of the camshaft bearings as described on page 116.

Proceed with tightening in two moments, following the order indicated in the figure.

Carry out the first tightening operation at a torque of 5Nm and the second at 10Nm. At the end of this operation, make sure the camshaft moves freely.

3.17.17 VALVE PLAY

Checking for valve play must be carried out by placing a thickness gauge **A** (code 006140210000) in between the cam and the rocker arm. This control can be done even without the hydraulic tensioner coupled to the engine.

Attention:

The piston must be positioned at the Top Dead Centre (par. 2.7)! Following the order of this text, this position is already fixed.

Play must be within the values carried on the table below.

Side	Minimum [mm]	Maximum [mm]
Intake	0.10	0.175
Exhaust	0.125	0.20

If the play measured is greater than that indicated, the calibrated disc must be replaced with a thicker one. On the contrary, if the valve play is less than that indicated, replace the calibrated disc with a thinner one.

The value of the needed thickness can easily be assessed by calculating the difference between the detected play value and the one required. The following is a layout for calibrated disc replacement.

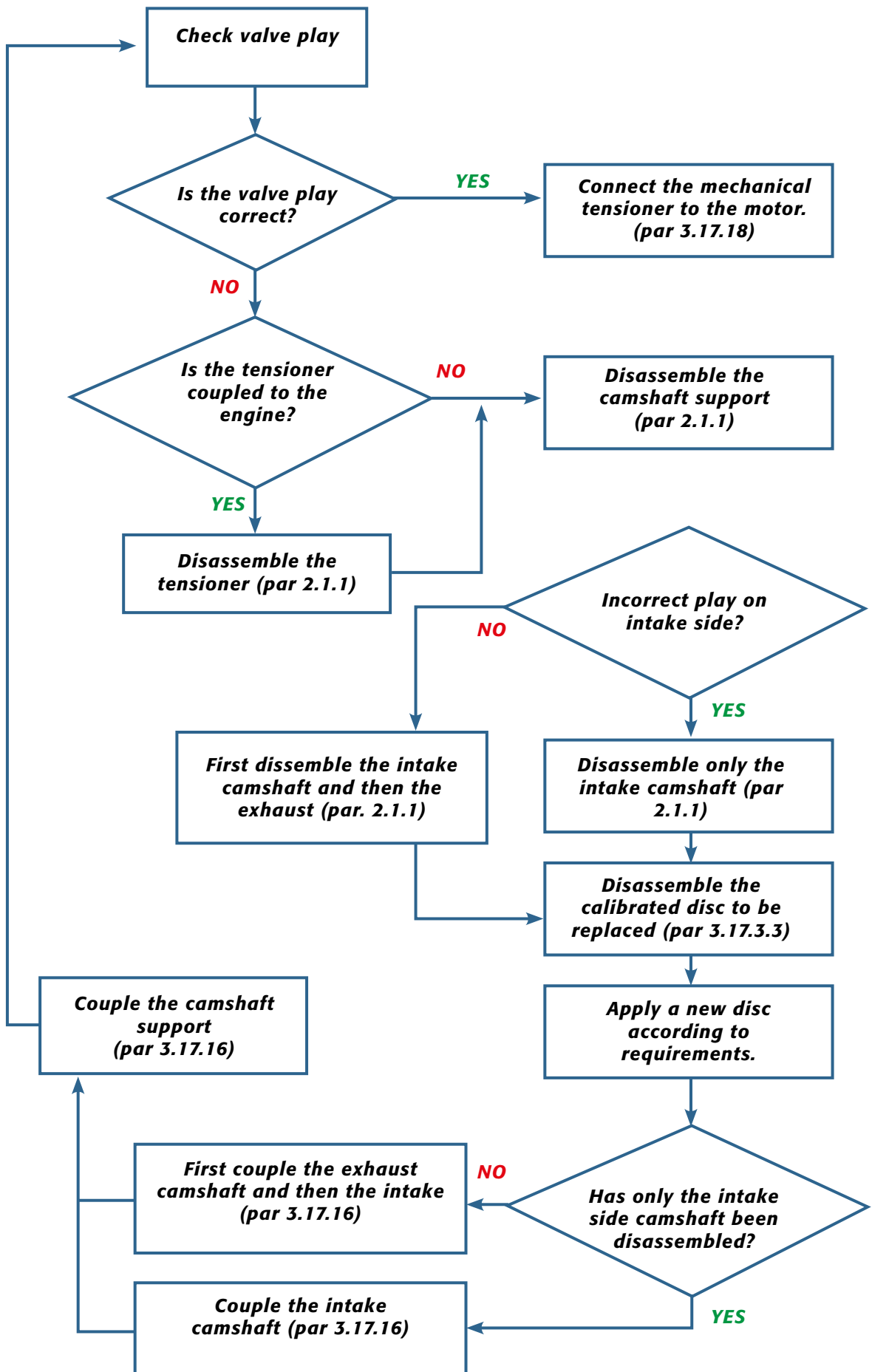

3.17.18 CHECKING AND COUPLING OF MECHANICAL TENSIONER TO ENGINE

The mechanical tensioner consists in:

1. a piston;
2. a spring;
3. a support;
4. a cap

Make sure the piston shows no signs of abnormal meshing.

Check that the length of the spring is not lower than the following limit value:

Spring limit length: 74mm

Insert the piston into the support and push it until it sticks out of the edge of the support by approximately 1 millimetre.

Insert the tensioner support in the specific seat on the cylinder, tightening it to the indicated torque and push the piston towards the front of the engine.

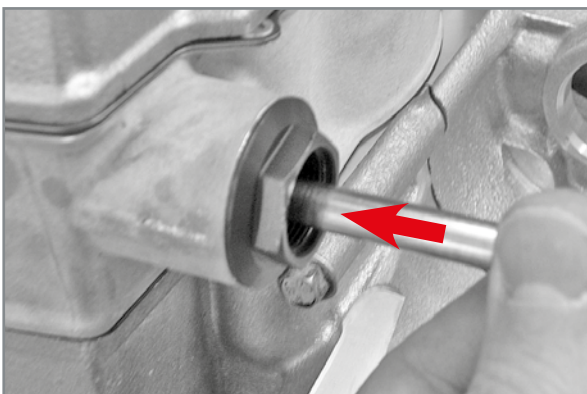
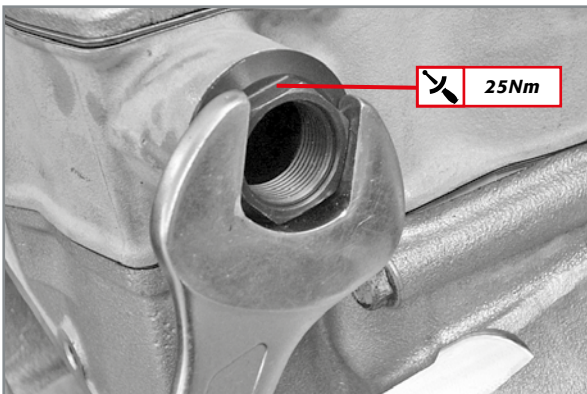
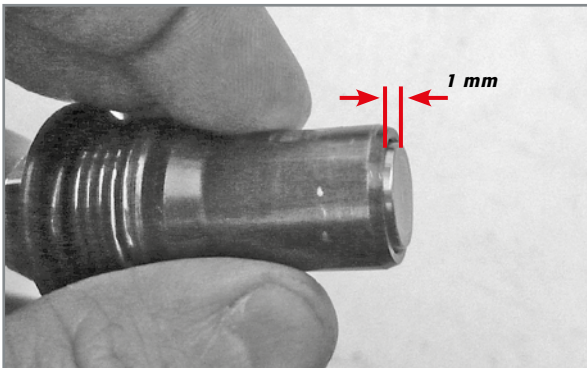
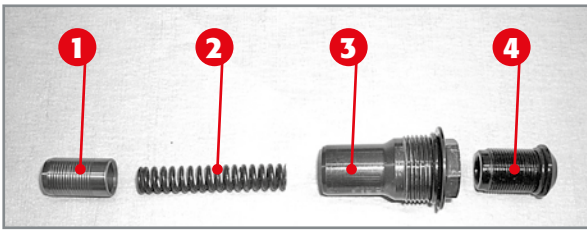

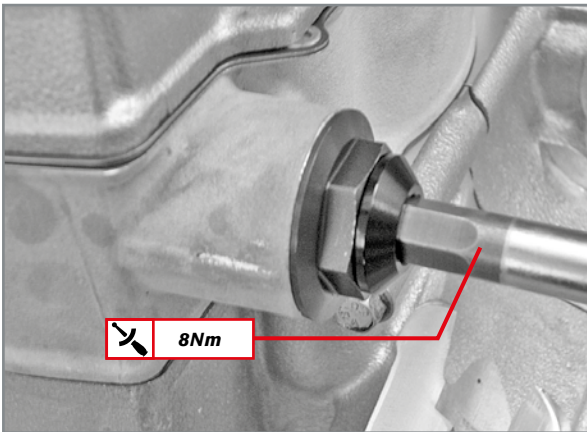
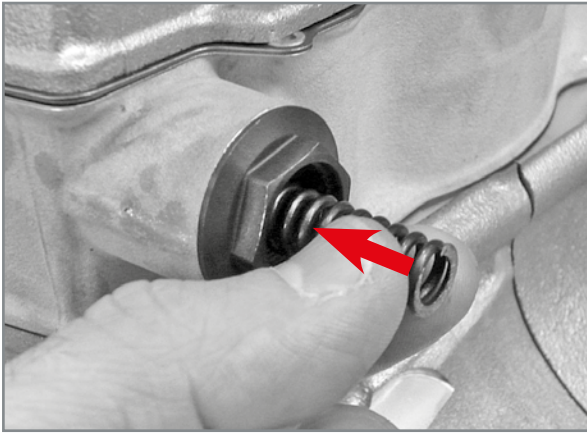

Insert the spring in the support and apply the cap to be tightened to the indicated torque.

3.17.19 COUPLING CYLINDER HEAD COVER GASKETS AND CYLINDER HEAD COVER

Apply the spark plug gasket 1 to the camshaft support inserting the two pegs **A** in the specific seats and positioning it so that it recopies the shape on the support.

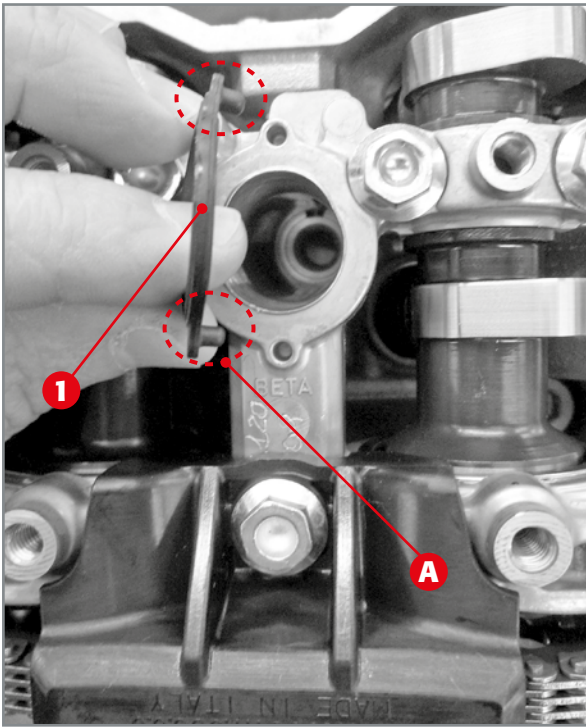

Application of spark plug gasket.

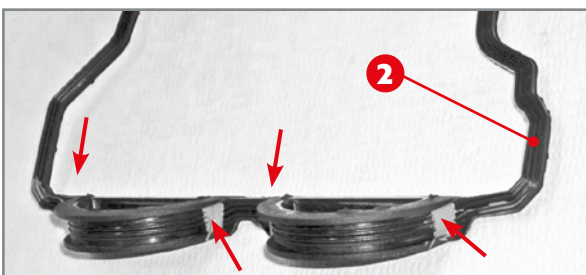
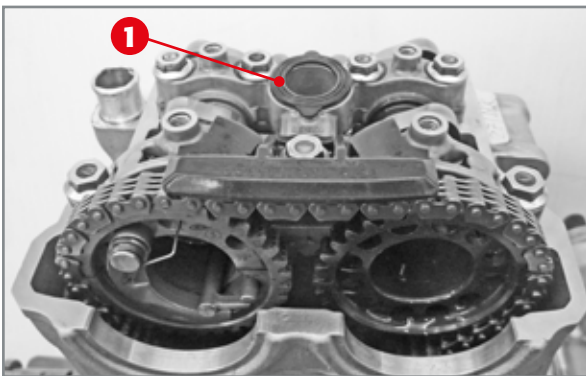

Edges where the gasket paste must be applied.



Insertion of gasket in groove on cylinder head cover.

Apply a few drops of gasket paste in the edges of the cylinder head cover gasket 2.

Insert the gasket in the cylinder head cover so that the protruding part fits perfectly into the groove in the cover.

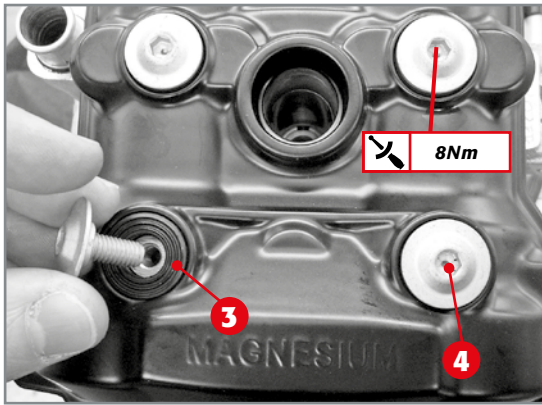

Application of rubber rings 3 and fixing screws 4.

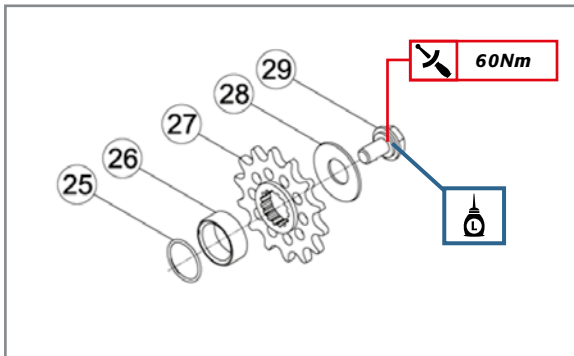

Exploded view of pinion unit. 25) O-ring 25x12x1.78; 26) Spacer 27) Pinion; 28) Washer; 29) Screw.

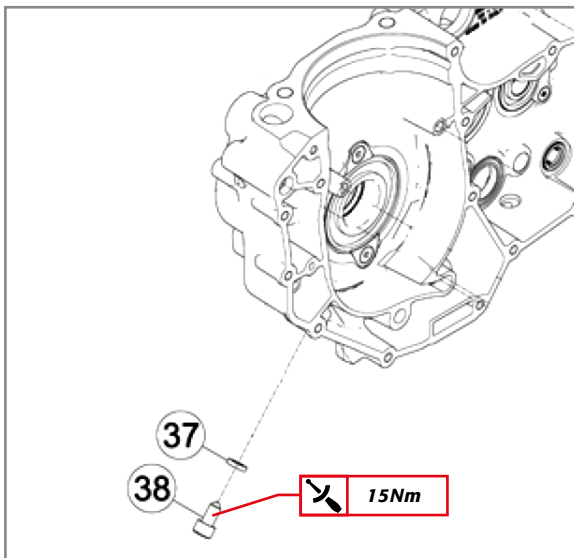

Place the complete cover on the cylinder head making sure that the gasket covers the surface correctly. Apply the four rubber rings 3 to the cover and insert the four screws 4 which fasten the cover to the cylinder head. Tighten the screws in a criss-cross pattern to the indicated torque.

3.18 PINION COUPLING

If the O-ring 25 is not coupled to the secondary shaft (par. 2.5), insert it followed by the spacer 26. Then apply the pinion 27, the washer 28 and the screw 29 which must be spread with medium strength threadlocker: tighten to the specified torque.

Attention:
do not use pneumatic devices!

3.19 RELEASING THE CRANKSHAFT

Remember that according to the order of this text, the crankshaft is blocked at the Top Dead Centre. It must be released by removing the screw 38 and applying the copper washer 37. Therefore reapply the screw-washer unit, tightened to the specified torque.

3.20 COUPLING OIL CAPS

Couple the engine oil drain plug **24** in the lower part of the right crankcase half, complete with O-ring **25**, with wire metal filter **27** and O-ring **26**. Tighten at the specified torque.

Apply the magnetic screw **28** with the O-ring **29** to the gear oil drain hole: tighten to the indicated torque.

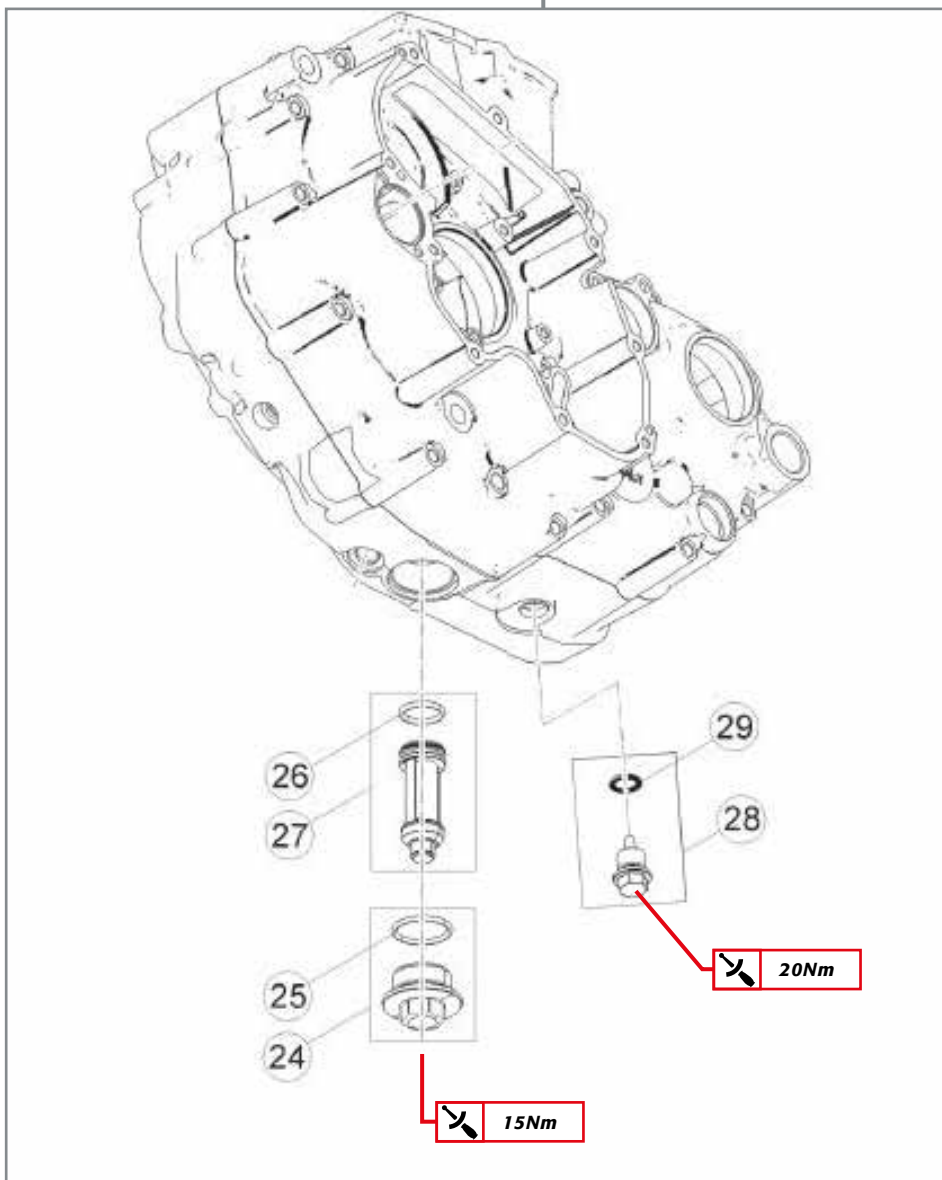

EXPLODED VIEW OF OIL DRAIN CAPS.

- 24) Motor oil drain plug;
- 25) O-ring 27x2;
- 26) O-ring 20x1.5;
- 27) Metal filter;
- 28) Magnetic screw;
- 29) O-ring 11x2.5

3.21 COUPLING GEARSHIFT LEVER

Couple the gearshift lever to the drive shaft by positioning it so that the part **A** of the lever coincides with the upper edge of the oil level inspection window.

Tighten the screw **1** to the specified torque after having applied medium strength threadlocker.

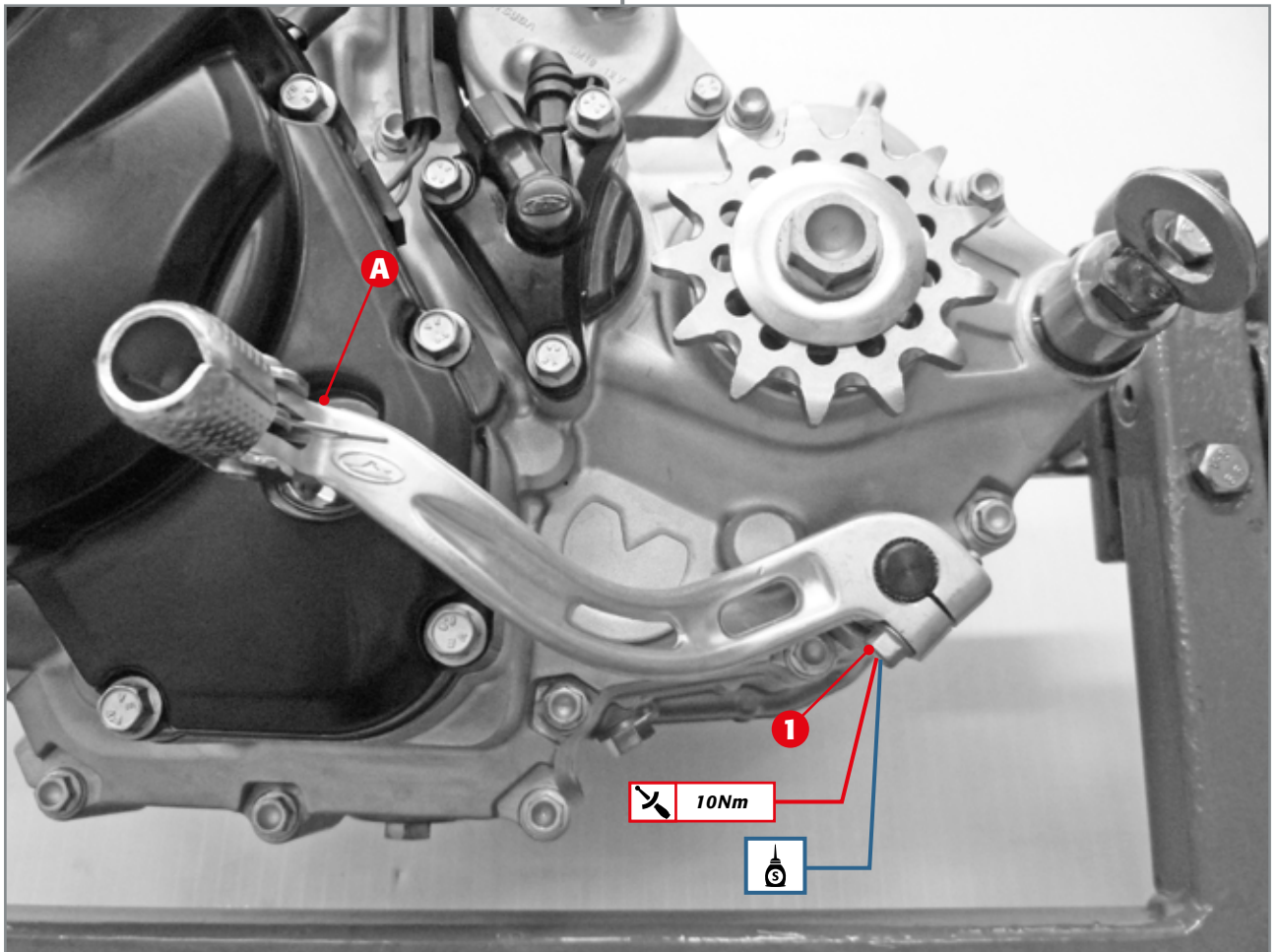

Positioning of gearshift lever.

4 REASSEMBLY OF ENGINE IN THE VEHICLE

4

REASSEMBLY OF ENGINE IN THE VEHICLE

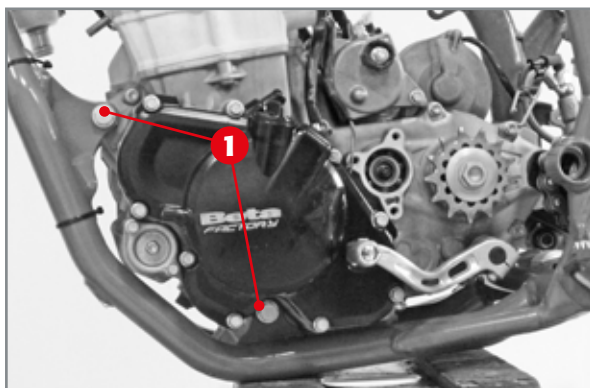

Insertion of engine pins.

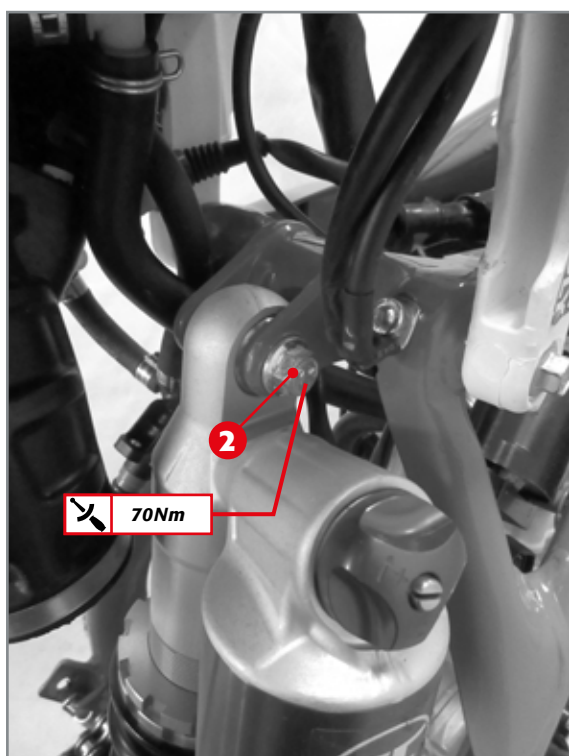

Insertion of upper shock absorber pin.

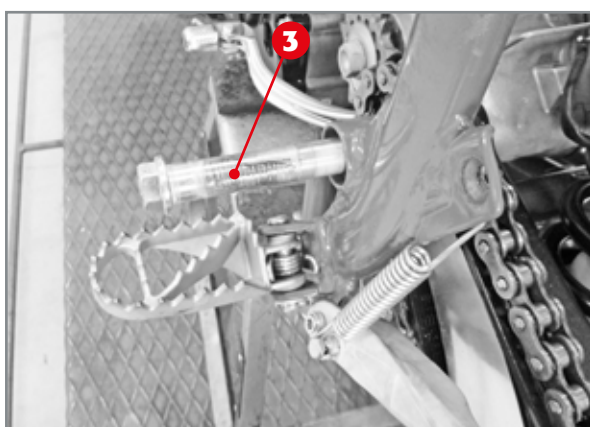

Insertion of swing-arm pin.

Insert the engine in the frame. We recommend insertion from the frame's left side.
Insert the engine pins 1.

Insert the upper shock absorber pin 2 and the swingarm pin 3. Fasten the shock absorber pin to the indicated torque.



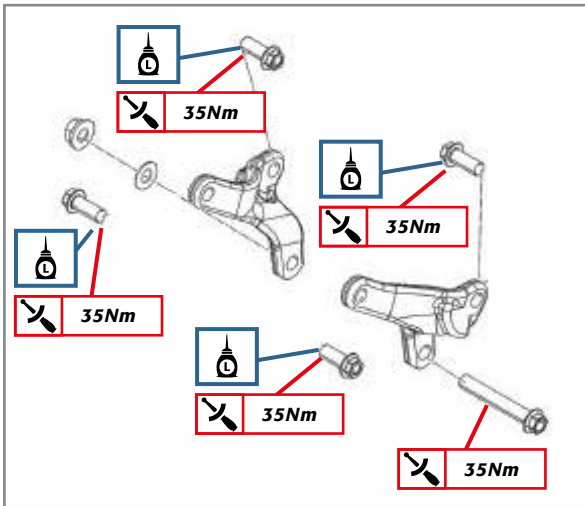

Apply the head connections.

Fasten the nuts and bolts following the table below.

Fixing	Screw	Torque [Nm]	Threadlocker
Head connection bracket to frame. Front fixing	M8 x 20	35	Medium-resistance
Head connection bracket to frame. Rear fixing	M8 x 16	35	Medium-resistance
Head connection brackets to engine	M8 x 65	35	
Engine pins	Special	45	
Swingarm pin	M16 x 245	125	

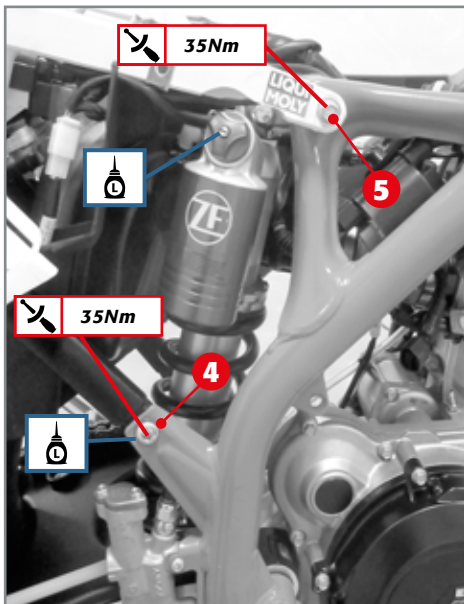

Put the throttle body on the manifold.

Rotate the filter box in its normal position. Apply the lower fixing screws **4** (one each side) prior application of medium strength threadlocker and fasten to the indicated torque.

Tighten the upper screws **5** to the indicated torque.

Note: we recommend removing the upper screws (one each side) and apply medium strength threadlocker.

Attention! During rotation, make sure the injector does not hit anything.

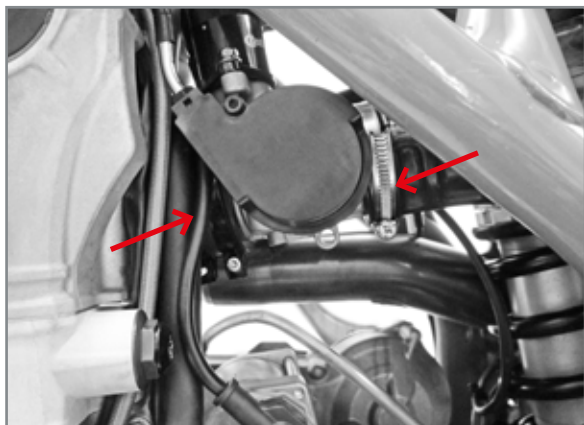

Make sure the filter box sleeve is correctly inserted inside the throttle body, fasten the two filter box side and manifold side straps.



Set the gas cable on the left side of the frame and make it pass outside the head connection. Apply the gas cables to the throttle body and tighten the nuts.

Attention! At the end of the operation, check for correct gas play.



Apply the throttle body cover and the relative screw. Connect the stop connectors.

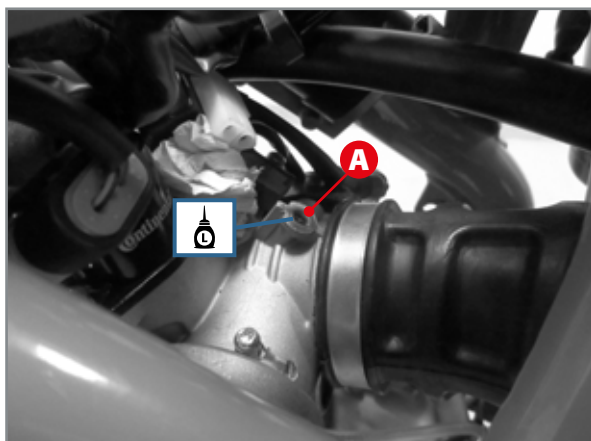

Apply a drop of medium resistance threadlocker to threaded bore **A**. Remove the protective cloth applied previously in the injector housing. Put the injector into its seat on the throttle body and push it all the way in.

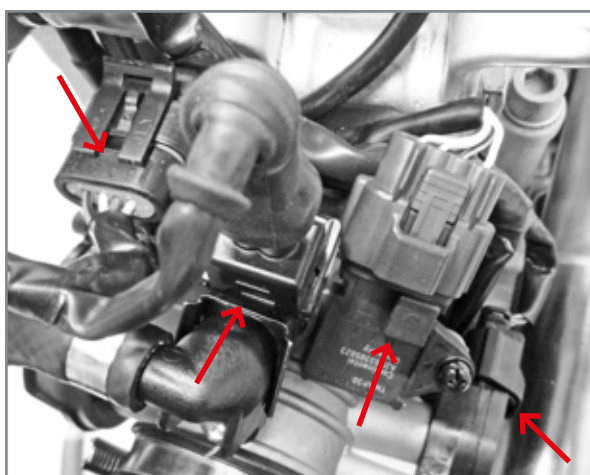
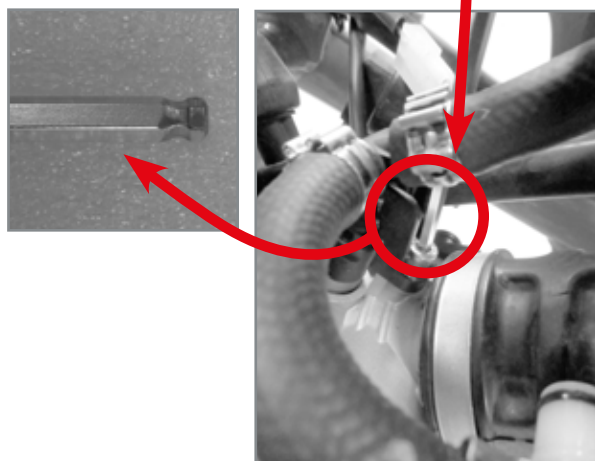
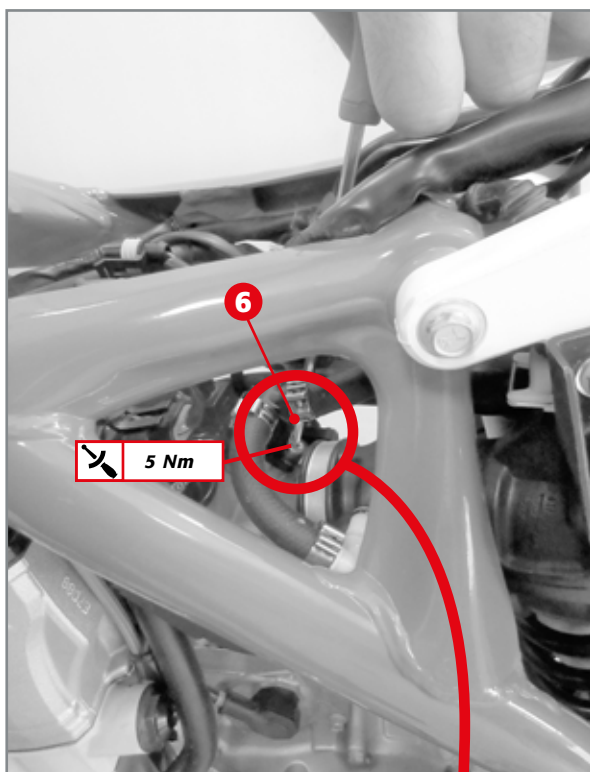

Fit the screw 6.

ATTENTION! Take the utmost care to make sure screw 6 is perfectly aligned with the respective threading. Should the screw not be perfectly aligned with the threading, **DO NOT FORCE IT while tightening. Instead, remove it and reposition it properly.** We recommend using a key like the one shown in the figure during handling. Tighten at the specified torque.

Connect the electric connectors indicated in the figure, relative to the throttle body.

Note. Before making the connection, it is advisable to blow compressed air in the connectors and treat them with spray for electrical contacts.

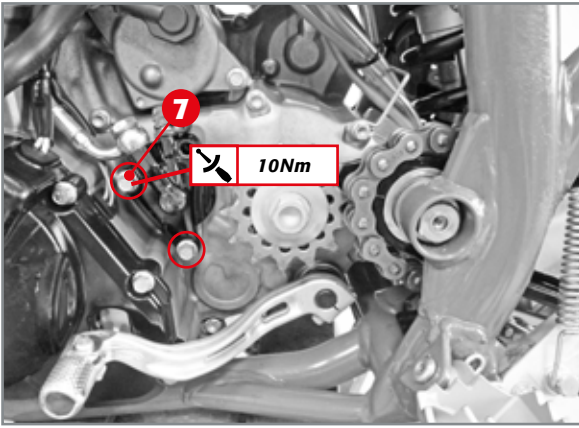

Apply the unit clutch actuator to the two fixing screws **7**.
Tighten to 10Nm.



Apply the spark plug cap.

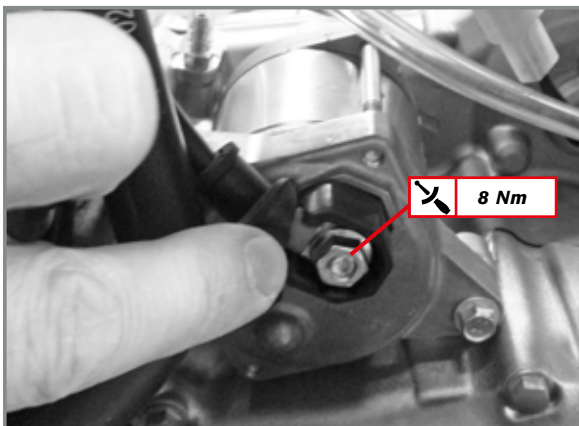

Apply the start motor cable and tighten the nut to the indicated torque.
Cover the connection using the specific protective cap.

Note. It is advisable to protect the electrical connector with a light veil of technical vaseline.

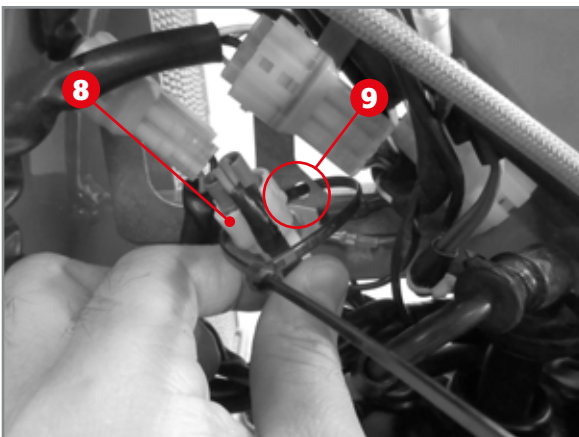

Disconnect the connector **8**.
Fasten the connector **8** with a plastic tie, feeding it through the specific hole **9**.

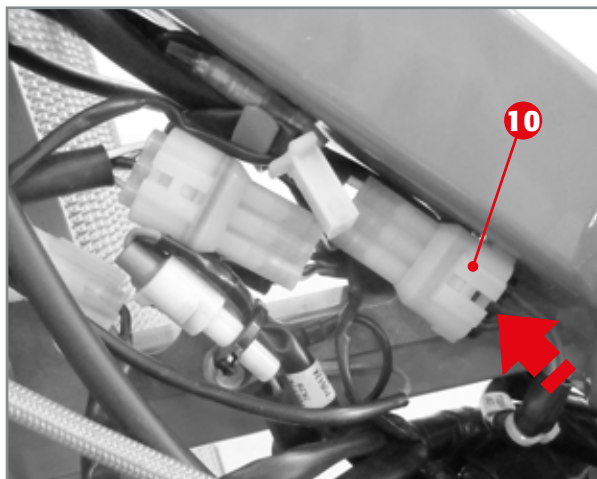

Connect the connector **10**.

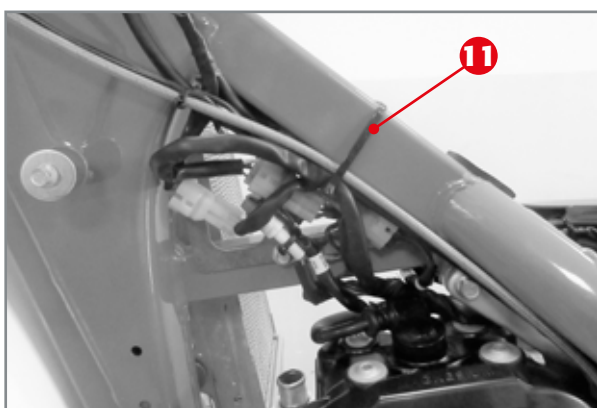

Apply a plastic tie **11** in order to collect the cables and pipes as shown.

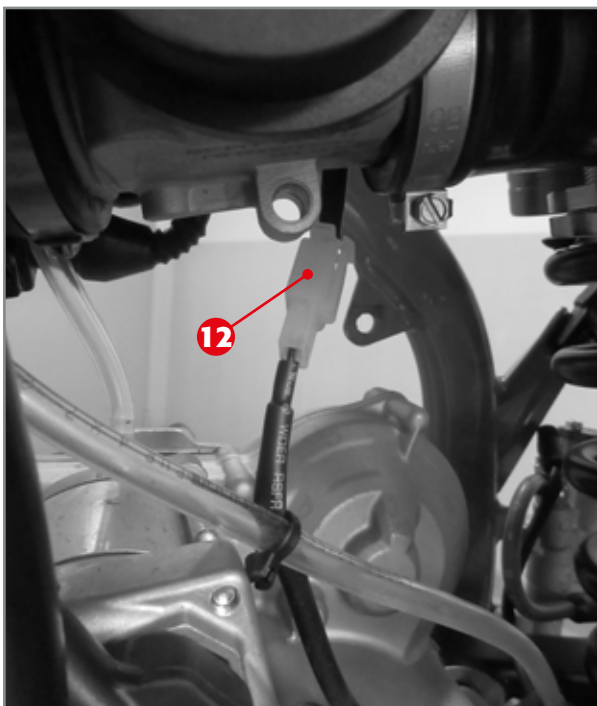

Connect the stop connector **12**.

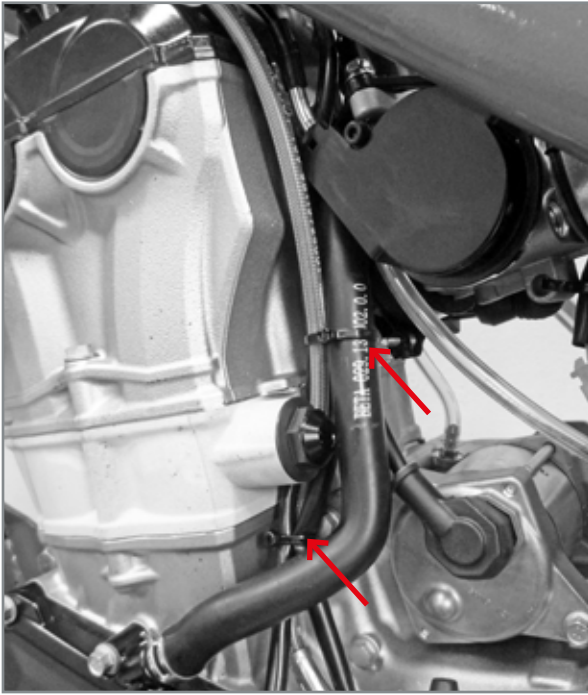

Connect the ventilation pipes to the engine.

Fix the cables from the engine to the gear actuator tube.

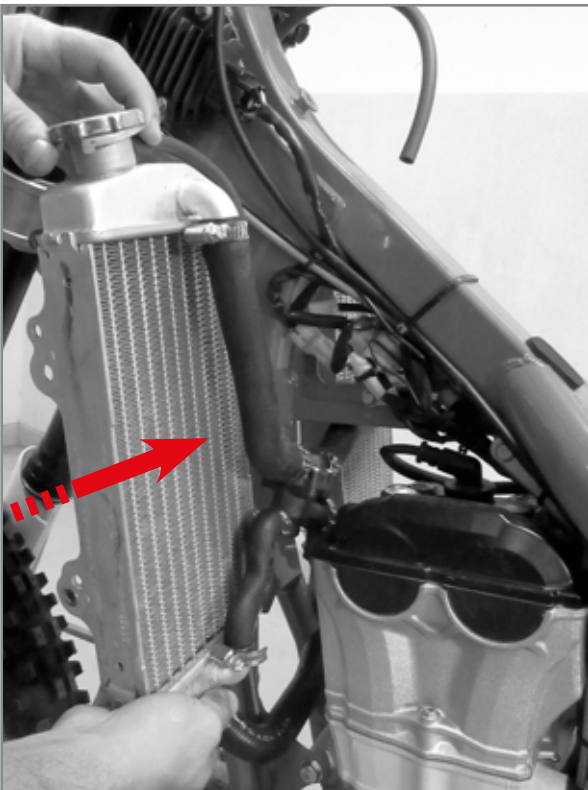

Apply the left radiator to the frame.

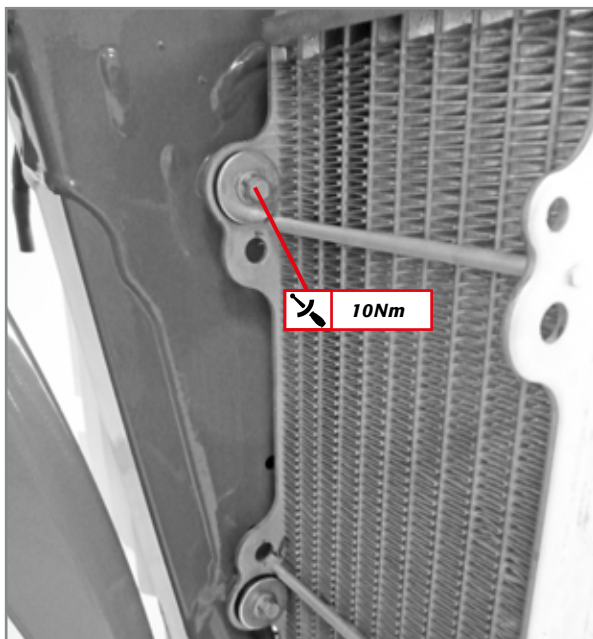

Apply the respective screws and tighten to the specified torque.

Apply the protective grid.

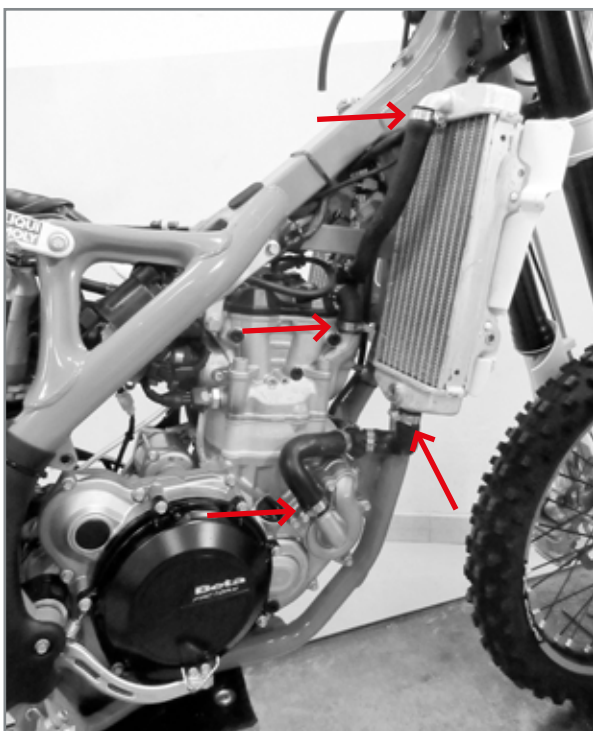

Connect the radiators to the engine.

Fasten the clamp straps and introduce the coolant liquid, letting the air bleed through the screw cap **A**.

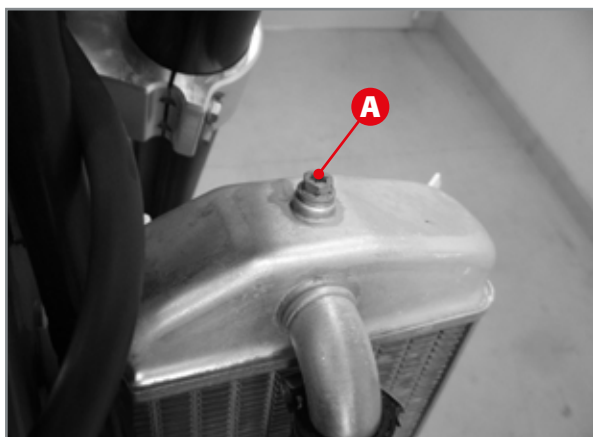

Apply the loading cap and fasten the bleed screw at 10Nm.

Air bleeding.



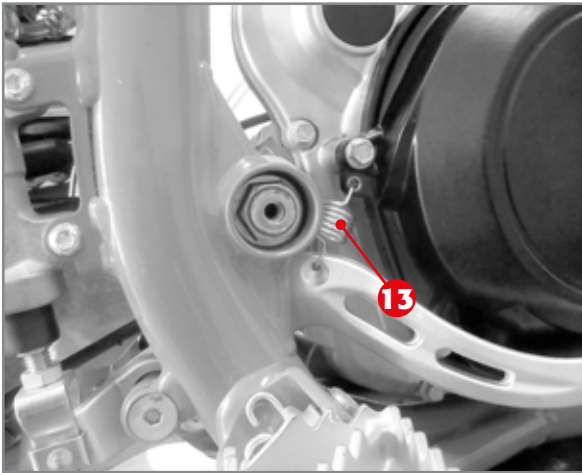

Apply the Kickstart lever (optional). Apply the dedicated medium-strength threadlocker on the screw and fasten at 25Nm.
Apply the brake pedal return spring **13**.

Mount the chain on the pinion.

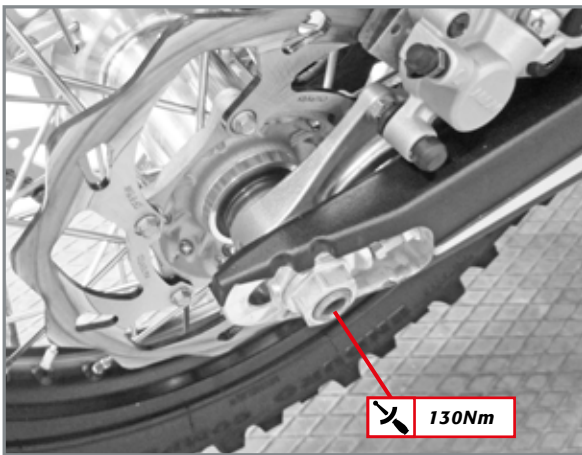

Move the wheel towards the rear, mounting the adjustment frames according to the image.

Attention! Before fastening the rear wheel, check for its correct alignment.

Tighten the nut to the indicated torque.

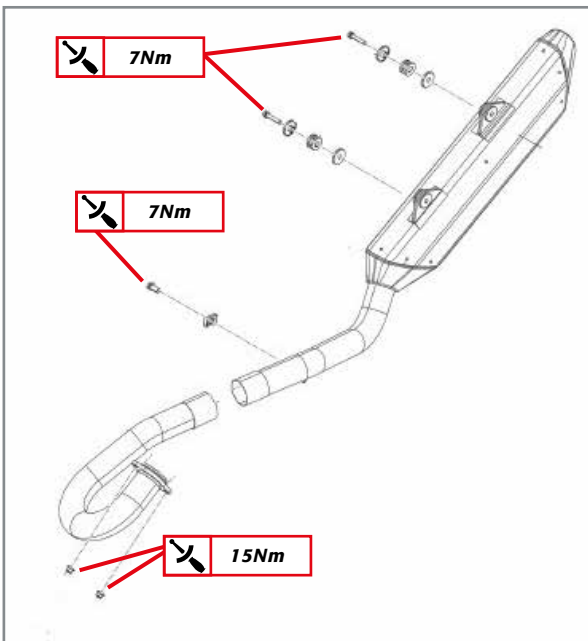

Apply the silencer to the vehicle, then the exhaust manifold; fasten according to the torque indicated in the figure.

Attention! Position the exhaust manifold in order to have a 5÷10mm gap with the water hose.

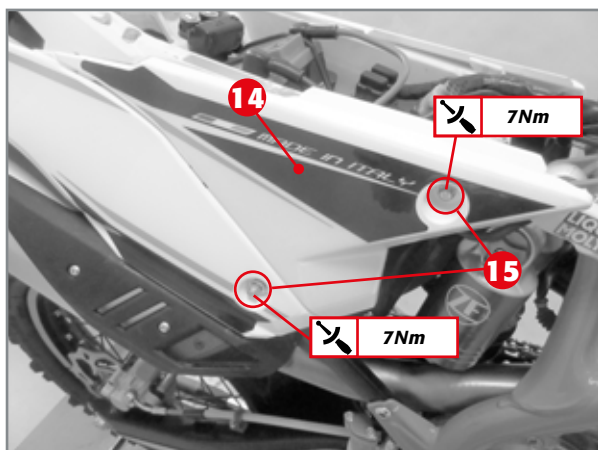

Apply the side panel **14** and tighten the screws **15** to the specified torque.

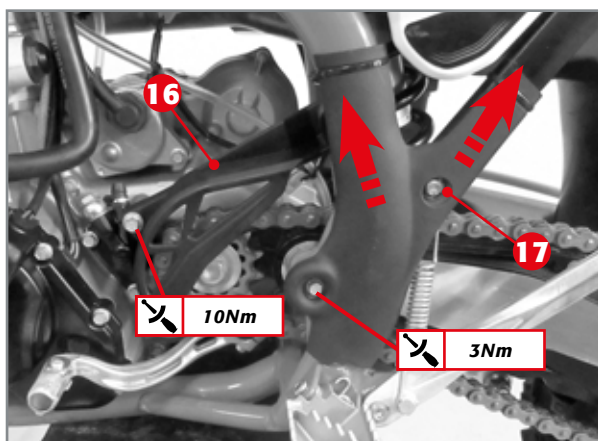

Apply the pinion guard **16** and the frame side guards **17** and **18**.

Fasten the screws at 10Nm and apply the fixing straps between the side guards and frame.

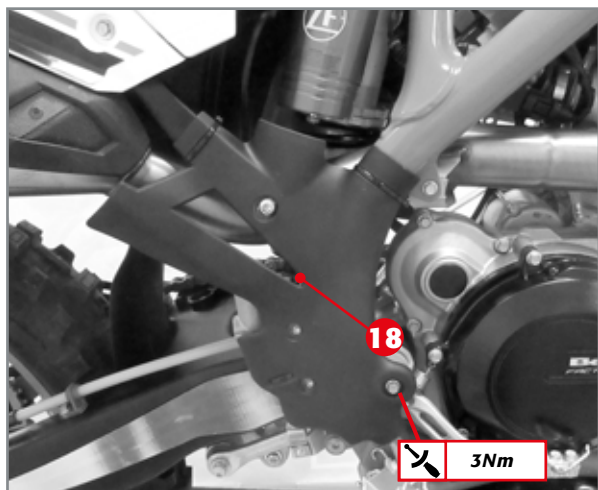

Apply the tank as follows.

Connect the connectors indicated in the figure.



Put the tank in place making sure the gas cable is between the tank and frame.

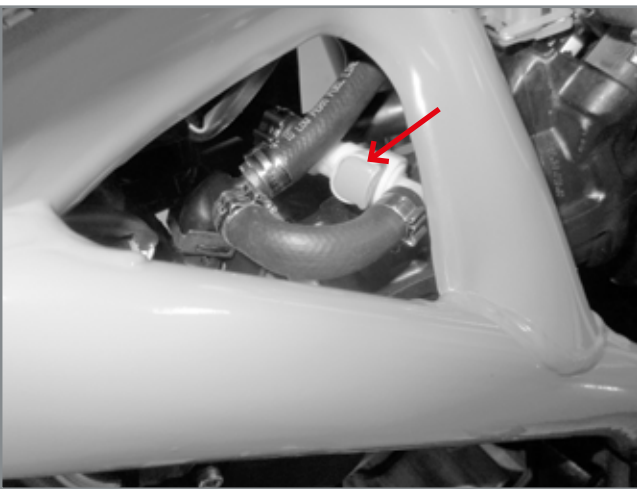

Connect the quick-release petrol couplings.

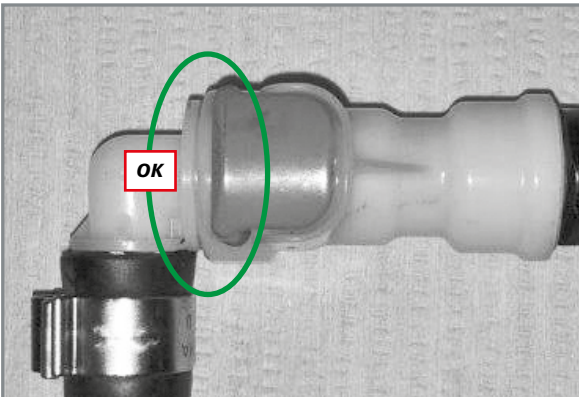

Attention! Make sure that the petrol quick-release couplings are fitted properly.

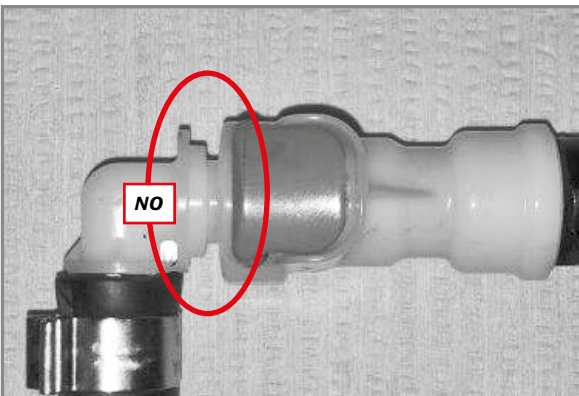

Fasten the screws in the tank to the indicated torque.

Apply the seat.

Reapply the paramotor plate with the tree fixing screws, once the motorcycle is removed Tighten to 10Nm.



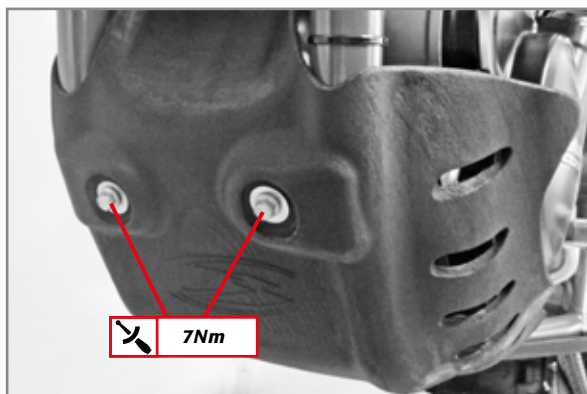
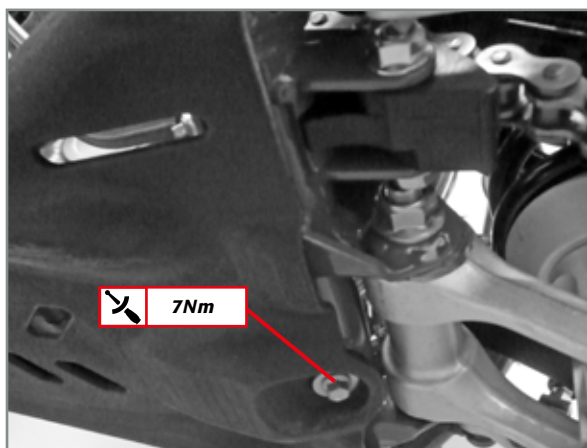
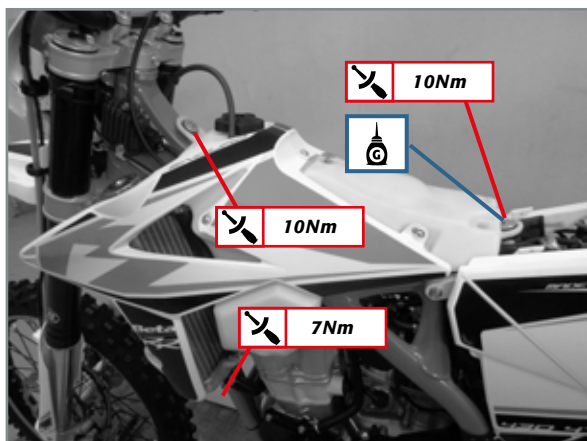

Grease the rear fastener and tighten the screws at the indicated torque values.

Apply the seat.

Apply the engine guard and relative screws.

Tighten at the specified torque.

TABLE OF ENGINE COMPONENTS FASTENING TORQUES

<i>Fixing</i>	<i>Threading diameter x length [mm]</i>	<i>Quantity</i>	<i>Threadlocker</i>	<i>Torque [Nm]</i>	<i>Notes</i>
Outer side right crankcase half					
<i>Oil seal fixing plate</i>	<i>M5 x 10</i>	<i>2</i>	<i>Medium-resistance threadlocker</i>	<i>6</i>	
<i>Oil incline</i>	<i>M5 x 10</i>	<i>2</i>	<i>Medium-resistance threadlocker</i>	<i>4</i>	
<i>Kickstart ramp</i>	<i>M6 x 20</i>	<i>1</i>	<i>Medium-resistance threadlocker</i>	<i>10</i>	
Inner side right crankcase half					
<i>Crankshaft bearing fixing plates</i>	<i>M6 x 12</i>	<i>2</i>	<i>Medium-resistance threadlocker</i>	<i>8</i>	
<i>Gearbox mainshaft bearing fixing plate</i>	<i>M6 X 12</i>	<i>2</i>	<i>Medium-resistance threadlocker</i>	<i>8</i>	
<i>Secondary gearbox shaft bearing fixing plate</i>	<i>M6 X 12</i>	<i>2</i>	<i>Medium-resistance threadlocker</i>	<i>8</i>	
<i>Desmodromic control bearing fixing</i>	<i>M5 X 10</i>	<i>2</i>	<i>Medium-resistance threadlocker</i>	<i>4</i>	
<i>Crankcase half coupling</i>	<i>M6 X 60</i>	<i>2</i>		<i>10</i>	
<i>Crankcase half coupling</i>	<i>M6 X 30</i>	<i>2</i>		<i>10</i>	
Outside left crankcase half					
<i>Countershaft bearing fixing</i>	<i>M6 X 12</i>	<i>12</i>	<i>Medium-resistance threadlocker</i>	<i>8</i>	
<i>Calibrated screw</i>	<i>M5</i>	<i>1</i>	<i>Medium-resistance threadlocker</i>		<i>Tighten all the way</i>
<i>Oil jet</i>	<i>M4</i>	<i>1</i>	<i>Medium-resistance threadlocker</i>		<i>Tighten all the way</i>
Inside left crankcase half					
<i>Crankshaft bearing fixing plates</i>	<i>M6 x 12</i>	<i>2</i>	<i>Medium-resistance threadlocker</i>	<i>8</i>	
<i>Crankcase half coupling</i>	<i>M6 x 70</i>	<i>4</i>		<i>10</i>	
<i>Crankcase half coupling</i>	<i>M6 X 60</i>	<i>9</i>		<i>10</i>	
Crankshaft					
<i>Left-hand side nut</i>	<i>M32</i>	<i>1</i>	<i>Medium-resistance threadlocker</i>	<i>150</i>	
<i>Right-hand side nut</i>	<i>M20</i>	<i>1</i>	<i>Medium-resistance threadlocker</i>	<i>150</i>	<i>Left Thread.</i>
<i>Crankshaft blocking</i>	<i>M8x16</i>	<i>1</i>		<i>15</i>	<i>With copper spacer</i>
Gearshift					
<i>Stop cam</i>	<i>M6 x 30</i>	<i>1</i>	<i>Medium-resistance threadlocker</i>	<i>10</i>	
<i>Stopping device lever</i>	<i>M6 x 20</i>	<i>1</i>	<i>Medium-resistance threadlocker</i>	<i>10</i>	
<i>Gearshift lever</i>	<i>M6 x 25</i>	<i>1</i>	<i>Medium-resistance threadlocker</i>	<i>10</i>	
Electric kickstarter device					
<i>Torque limiter</i>	<i>M6 x 25</i>	<i>1</i>	<i>Medium-resistance threadlocker</i>	<i>10</i>	
<i>Start motor</i>	<i>M6 x 20</i>	<i>2</i>	<i>Medium-resistance threadlocker</i>	<i>10</i>	



<i>Fixing</i>	<i>Threading diameter x length [mm]</i>	<i>Quantity</i>	<i>Threadlocker</i>	<i>Torque [Nm]</i>	<i>Notes</i>
Engine lubrication					
<i>Oil jet</i>	<i>M4</i>	<i>10</i>	<i>Medium-resistance threadlocker</i>	<i>6</i>	
<i>Oil pump covers</i>	<i>M5 x 10</i>	<i>5</i>	<i>Medium-resistance threadlocker</i>	<i>4</i>	
<i>Chain oil jet</i>	<i>M5 x 12</i>	<i>1</i>	<i>Medium-resistance threadlocker</i>	<i>6</i>	
<i>Oil pressure control screw</i>	<i>M12 x 10</i>	<i>1</i>		<i>20</i>	
<i>Paper oil filter cap</i>	<i>M6 x 16</i>	<i>2</i>		<i>10</i>	
Countershaft					
<i>Locking nut</i>	<i>M12</i>	<i>1</i>	<i>Medium-resistance threadlocker</i>	<i>50</i>	
Clutch					
<i>Drum nut and clutch case</i>	<i>M18</i>	<i>1</i>	<i>Medium-resistance threadlocker</i>	<i>120</i>	
<i>Clutch pressure cap</i>	<i>M6 x 25</i>	<i>6</i>		<i>10</i>	
<i>Clutch actuator</i>	<i>M6 x 20</i>	<i>2</i>		<i>10</i>	
<i>Clutch actuator</i>	<i>M6 x 30</i>	<i>1</i>		<i>10</i>	
<i>Outer clutch cover</i>	<i>M6 x 25</i>	<i>6</i>		<i>10</i>	
<i>Outer clutch cover</i>	<i>M6 x 30</i>	<i>1</i>		<i>10</i>	
<i>Inner clutch cover</i>	<i>M6 x 25</i>	<i>9</i>		<i>10</i>	<i>See water pump cover screws as well</i>
Water pump					
<i>Impeller blind nut</i>	<i>M6</i>	<i>1</i>	<i>Medium-resistance threadlocker</i>	<i>6</i>	
<i>Cover</i>	<i>M6 x 40</i>	<i>4</i>		<i>10</i>	
Timing chain guards					
<i>Fixed and movable guides</i>	<i>M6 x 25</i>	<i>2</i>	<i>Medium-resistance threadlocker</i>	<i>10</i>	
<i>Chain guide on flywheel cover</i>	<i>M5 x 10</i>	<i>1</i>	<i>Medium-resistance threadlocker</i>	<i>4</i>	
<i>Chain guard</i>	<i>M6 x 20</i>	<i>2</i>	<i>Medium-resistance threadlocker</i>	<i>10</i>	
Ignition system					
<i>Pick-up</i>	<i>M5 x 12</i>	<i>2</i>	<i>Medium-resistance threadlocker</i>	<i>6</i>	
<i>Stator winding</i>	<i>M5 x 30</i>	<i>3</i>	<i>Medium-resistance threadlocker</i>	<i>6</i>	
<i>Flyweel</i>	<i>M12</i>	<i>1</i>	<i>Medium-resistance threadlocker</i>	<i>60</i>	
<i>Spark plug</i>	<i>M12</i>	<i>1</i>		<i>17</i>	
<i>Cover</i>	<i>M6x25</i>	<i>9</i>		<i>10</i>	



<i>Fixing</i>	<i>Threading diameter x length [mm]</i>	<i>Quantity</i>	<i>Threadlocker</i>	<i>Torque [Nm]</i>	<i>Notes</i>
Head					
<i>Rocker arm pin caps</i>	<i>M10</i>	<i>2</i>		<i>10</i>	
<i>Head</i>	<i>M10</i>	<i>4</i>		<i>40 > 55</i>	<i>Lubricate threading and washers. Follow a criss-cross pattern</i>
<i>Head</i>	<i>M6</i>	<i>1</i>		<i>10</i>	
<i>Camshaft support</i>	<i>M7 x 38</i>	<i>3</i>		<i>8 > 10</i>	<i>Follow a criss-cross pattern</i>
<i>Camshaft support</i>	<i>M7 x 33</i>	<i>4</i>		<i>8 > 10</i>	<i>Follow a criss-cross pattern</i>
<i>Exhaust flange stud</i>	<i>M8 x 30</i>	<i>2</i>	<i>Medium-resistance threadlocker</i>		
<i>Electric fan sensor</i>	<i>M12</i>	<i>1</i>		<i>20</i>	
<i>AIS valve fitting</i>	<i>M10</i>	<i>1</i>		<i>10</i>	
<i>Cover</i>	<i>M6 x 12</i>	<i>4</i>		<i>8</i>	
Mechanical tensioner					
<i>Tensioner cap</i>	<i>M24</i>	<i>1</i>		<i>25</i>	
<i>Small tensioner cap</i>	<i>M16</i>	<i>1</i>		<i>8</i>	
Chain pinion					
<i>Pinion</i>	<i>M10 x 18</i>	<i>1</i>	<i>Medium-resistance threadlocker</i>	<i>60</i>	<i>Do not use pneumatic devices!</i>
Gearbox oil vapour breather					
<i>Bored screw</i>	<i>M6x1</i>	<i>1</i>	<i>Medium-resistance threadlocker</i>	<i>6</i>	
Oil drains					
<i>Motor oil plug</i>	<i>M20</i>	<i>1</i>		<i>15</i>	
<i>Magnetic screw gearbox oil plug</i>	<i>M14</i>	<i>1</i>		<i>20</i>	
Kickstarter					
<i>Kickstart lever</i>	<i>M8 x 26</i>	<i>1</i>	<i>Medium-resistance threadlocker</i>	<i>25</i>	<i>Do not use pneumatic devices!</i>



TABLE OF FRAME/ENGINE FASTENING TORQUES

<i>Fixing</i>	<i>Threading diameter x worm [mm]</i>	<i>Quantity</i>	<i>Threadlocker</i>	<i>Torque [Nm]</i>	<i>Notes</i>
<i>Front engine pin</i>	<i>M10 x 1.25</i>	<i>1</i>		<i>45</i>	
<i>Lower engine pin</i>	<i>M10 x 1.25</i>	<i>1</i>		<i>45</i>	
<i>Head connection bracket to front frame</i>	<i>M8x20</i>	<i>2</i>	<i>Medium-resistance threadlocker</i>	<i>35</i>	
<i>Head connection bracket to rear frame</i>	<i>M8x16</i>	<i>2</i>	<i>Medium-resistance threadlocker</i>	<i>35</i>	
<i>Head connection brackets to engine</i>	<i>M8x65</i>		<i>Medium-resistance threadlocker</i>	<i>35</i>	
<i>Swingarm pin</i>	<i>M16 x 1.5</i>	<i>1</i>		<i>125</i>	

TABLE OF SUPERSTRUCTURE FASTENING TORQUE VALUES

<i>Fixing</i>	<i>Threading diameter x worm [mm]</i>	<i>Length [mm]</i>	<i>Quantity</i>	<i>Threadlocker</i>	<i>Torque [Nm]</i>	<i>Notes</i>
<i>Tank to the frame (front fixing)</i>	<i>M6 x 1</i>	<i>25</i>	<i>1</i>		<i>10</i>	
<i>Tank to the frame (rear fixing)</i>	<i>M6 x 1</i>	<i>30</i>	<i>1</i>		<i>10</i>	<i>Application of grease</i>
<i>Tank side panel to the radiator</i>	<i>M6 x 1</i>	<i>20</i>	<i>2</i>		<i>7</i>	



RECOMMENDED ENGINE MAINTENANCE

The requested engine maintenance only depends on the level of use and respect of the periodical inspections. The following intervals refer to normal use, as long as the engine has not worked in extraordinary conditions and that periodical inspections and interventions have been correctly carried out.

	30h 200l	60h 400l	90h 600l	120h 600l	150h 800l	180h 1200l
Clutch disc wear	I	I	S	I	I	S
Clutch springs	I	I	S	I	I	S
Gearbox bearing (mainshaft)	-	-	S	-	-	S
Case / clutch hub	I	I	I	I	I	I
Cylinder	-	-	I	-	-	I
Piston and segments	-	-	S	-	-	S
Camshaft wear	-	-	I	-	-	I
Valve springs	-	-	I	-	-	S
Valves	-	-	I	-	-	S
Valve guide wear	-	-	I	-	-	I
Connecting rod	-	-	S	-	-	S
Countershaft bearings	-	-	S	-	-	S
Crankshaft bearings	-	-	S	-	-	S
Gearbox superficial look	-	-	I	-	-	I
Pressure control valve spring length	-	-	I	-	-	I
Seals for water pump + bush	-	-	S	-	-	S
Oil pumps control gearwheels	-	-	S	-	-	S

I = INSPECT AND REPLACE IN CASE OF NECESSARY S = REPLACE



RECOMMENDED LUBRICANTS AND LIQUIDS

APPLICATION	PRODUCT	QUANTITY
<i>Gearbox and clutch</i>	<i>Liqui Moly racing Synth 10W50</i>	<i>800 ml* - 750ml**</i>
<i>Engine</i>	<i>Liqui Moly racing Synth 10W50</i>	<i>800 ml* - 750ml**</i>
COOLANT LIQUID	<i>Liqui Moly Coolant ready mix RAF 12 PLUS</i>	<i>1300 ml*</i>

* Following the complete engine overhaul.

** Following routine maintenance interventions.





Beta
motorcycles

BETAMOTOR S.P.A.

PIAN DELL'ISOLA, 72

50067 RIGNANO SULL'ARNO (FIRENZE) ITALIA

INFO@BETAMOTOR.COM WWW.BETAMOTOR.COM