



X-Trainer 43mm fork service manual



© Beta USA, Inc. 2016

This work should be performed by a trained motorcycle technician.

Table of contents

	Page
Introduction/special tools.....	2
Fork exploded view.....	3
Legend.....	4
RH fork (Spring)disassembly.....	5
RH fork Reassembly.....	6
LH fork (Dampening) disassembly.....	9
Cartridge disassembly.....	10
Rebound assembly.....	11,12
Base valve assembly.....	11-14
LH fork reassembly.....	14-17

Introduction

The SFF or Single Function Fork refers to each fork having a specific duty, the right fork has the spring and the left handles the dampening.

For removal and replacement of the fork internals refer to the pages in this shop manual. These procedures must take place in a clean environment using professional tools and some special tools.

Take special care not to damage the surface of the fork, especially the stanchions and seal locations .

On the vise, always use protective jaws of brass or aluminum.

Clean all parts before assembly using lint free rags or towels to help avoid oil contamination.

Contamination inside the fork can affect the operation and may cause premature wear. Always replace worn or damaged parts.

CAUTION;

Disassembly and assembly of the fork or the incorrect use of aftermarket parts can cause malfunctions or serious risk to the safety of persons and property.

Therefore, before performing any maintenance, be sure to read and follow the instructions carefully as described in this manual.

Special tools

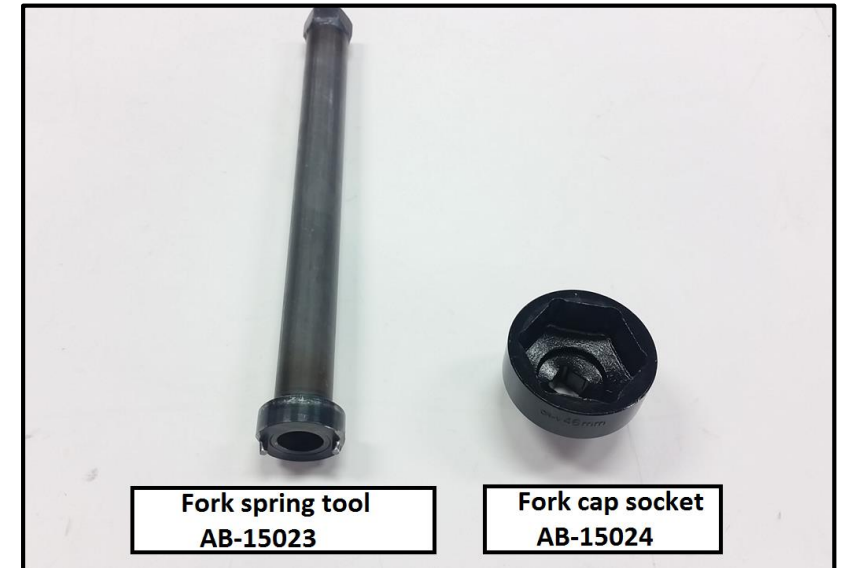

*2015 Fork spring tool AB-15023-15

*2016 Fork spring tool AB-15023-16

Exploded View

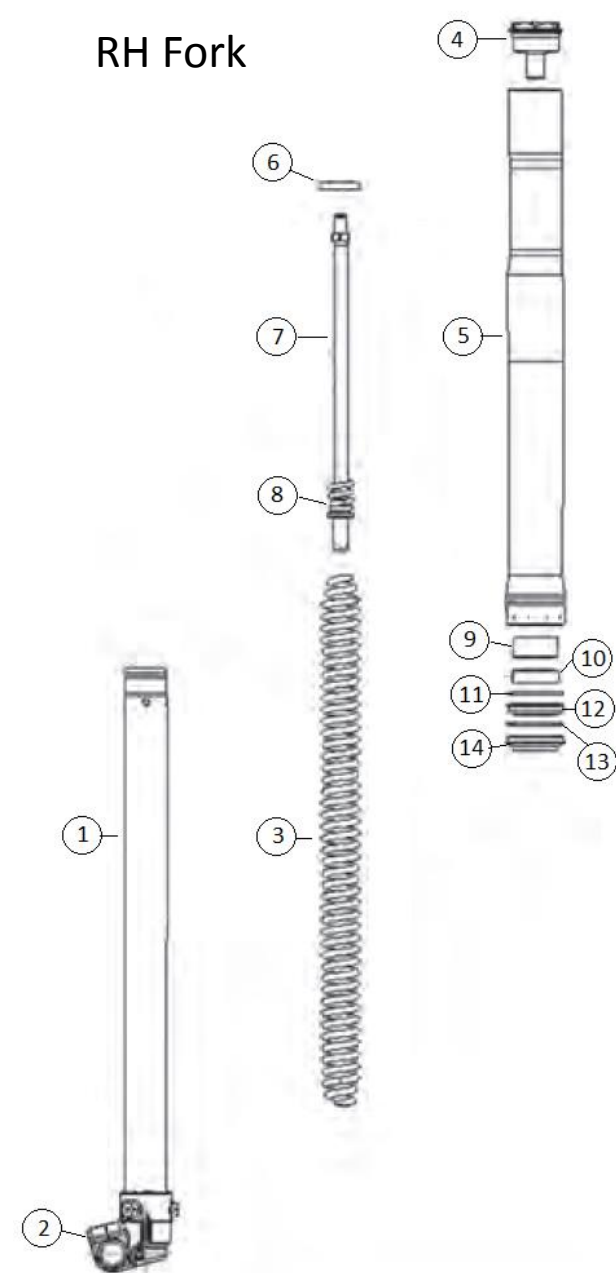
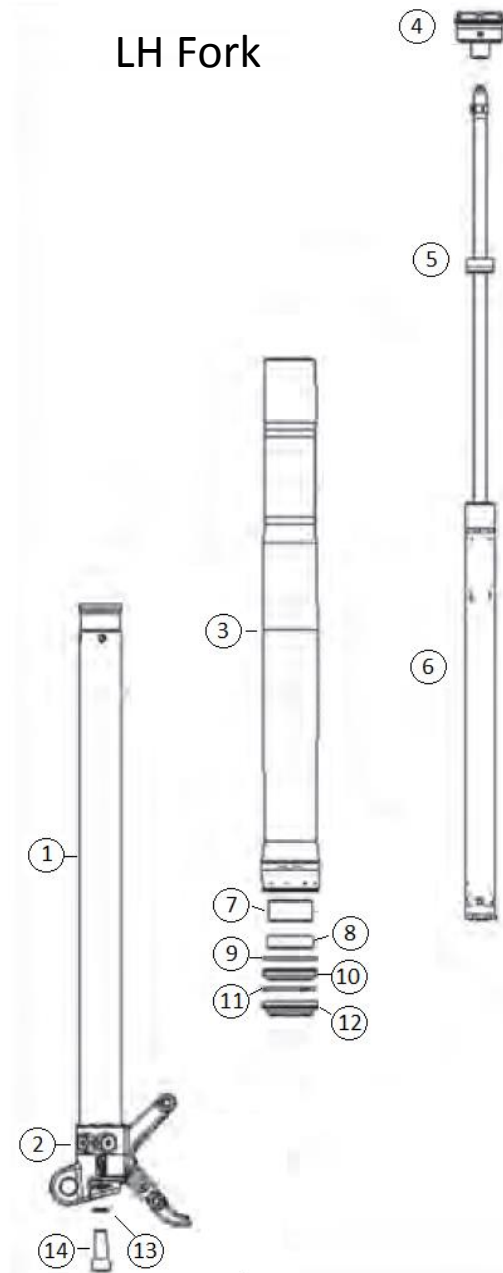

Legend

LH Fork

1. Inner fork tube
2. Axle lug/ Caliper hanger
3. Outer fork tube
4. Fork cap
5. Bottom out cone
6. Cartridge
7. Top guide bushing
8. Bottom guide bushing
9. Support washer
10. Fork seal
11. Retainer clip
12. Dust seal
13. Copper washer
14. 10mm Allen bolt

RH Fork

1. Inner fork tube
2. Axle lug
3. Fork spring
4. Fork cap
5. outer fork tube
6. Spring retainer cap
7. Metering rod
8. Top out spring
9. Top guide bushing
10. Bottom guide bushing
11. Support washer
12. Fork seal
13. Retainer clip
14. Dust seal



Spring side

Clamp the RH fork in a vise using soft jaws.

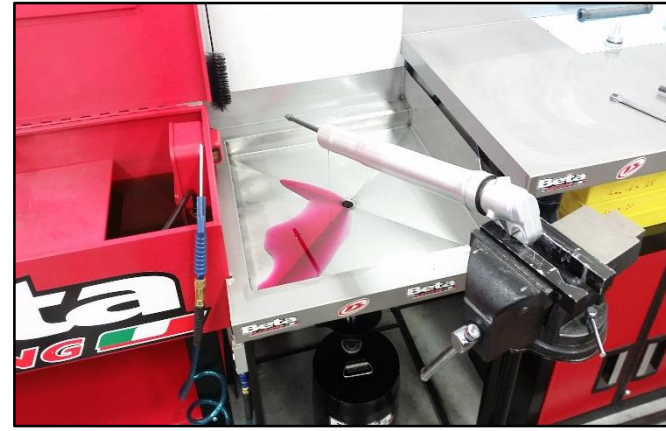

Drain the fork oil.



Use the fork cap tool to loosen the cap.



Pry the dust seal away from the outer fork tube.



Loosen the lock nut then remove the cap.

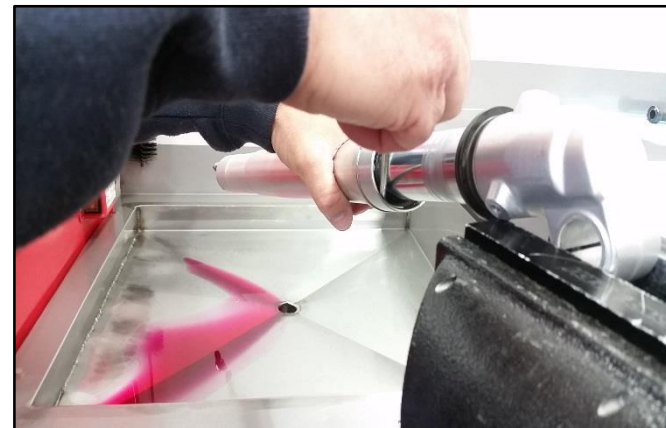

Remove the fork seal retainer clip.



Holding the fork with both hands and with one quick motion, pull the tubes apart.



Remove metering rod and spring. Thoroughly clean and inspect all parts, replace any worn or damaged parts.



Remove the bushings, retaining washer, fork seal, retaining clip and dust seal paying attention to the order of removal and orientation. Clean and inspect all parts, replace any worn bushings and seals.



Secure the cartridge in a soft jaw vise and use the fork spring removal tool to remove the spring retainer cap. Note: Heat maybe required to loosen the locking agent.



Place a seal bullet or a heavy duty bag over the lower leg.

Reassembly



Apply a high quality seal or O-ring grease to the fork seal and dust seal and apply fork oil to both sides of the bottom guide bushing. Install the bushing, seals and clip on the lower leg in the correct order and orientation.

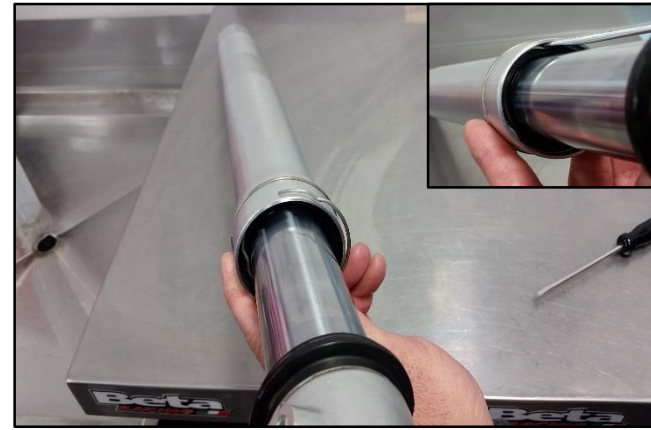

Insert the oil seal retainer clip making sure it is fully seated.

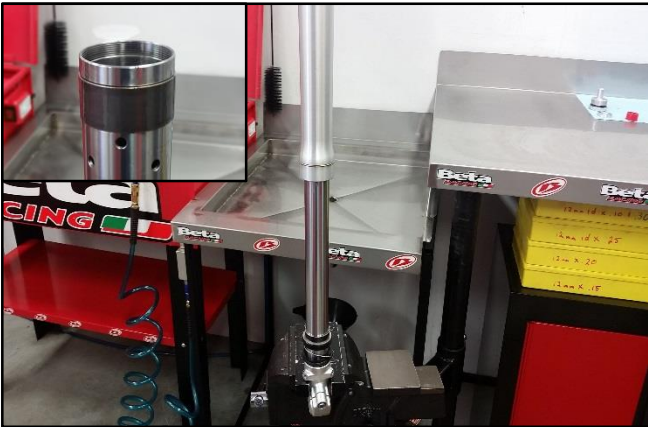

Apply fork oil to both sides of the top guide bushing then install it on the inner fork tube. Carefully slide the outer fork tube on to the lower tube.



Slide the outer leg down all the way to the axle lug to seat the dust seal.



Use a seal driver to install the seal and lower guide bushing.



Insert the spring tapered side up if only tapered on one side.



Insert the metering rod.



Fill the fork with high quality 5w fork oil to 500cc.



Put a drop of high strength thread locking agent onto the threads of the spring retainer cap and install, tighten to 40Nm.



Tighten the fork cap to 10Nm.



Reinstall the fork cap threading it on until it bottoms out. Run the nut up to the cap and tighten to 16Nm.



Dampening side

Clamp the LH fork in a soft jaw vise.

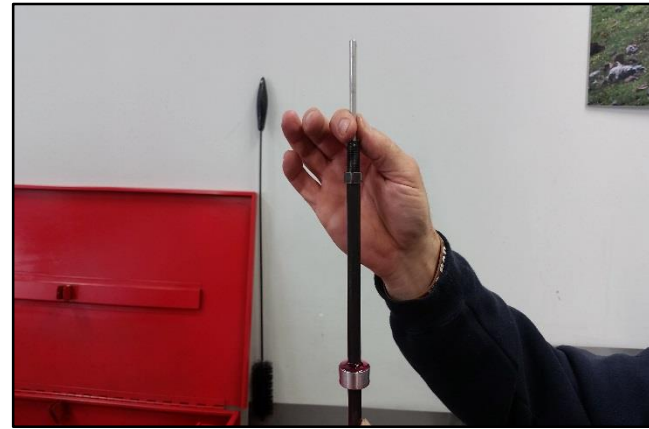

Remove the rebound adjuster rod from the damping rod.



Use the fork cap tool to loosen the cap.



Drain the fork oil.



Loosen the lock nut and remove the cap



Pry the dust seal away from the outer fork tube.



Remove the fork seal retainer clip.



Holding the fork with both hands and with one quick motion, pull the tubes apart.



Remove the 10mm Allen bolt and copper washer from the bottom of the fork.



Remove the bushings, retaining washer, fork seal, retaining clip and dust seal paying attention to the order of removal and orientation. Clean and inspect all parts, replace worn bushings and seals.



Remove the cartridge from the fork.



CAUTION: Hold the cartridge in the soft “V” jaw vice using paper between the jaws and cartridge and use only enough pressure to hold the cartridge, do not tighten or damage will occur.



Loosen the base valve by holding the 30mm top and loosen the base valve at the other end.

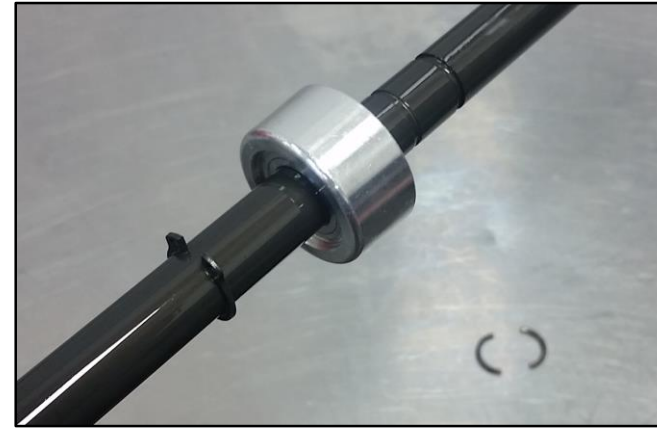

Slide the bottom out cone towards the circlip to expose the 2 piece clip on the other side being ready to catch the 2 clip pieces as you move the cone. Remove the locking nut and bottom out cone from the damping rod.



Remove the base valve.



Remove the damping rod from the cartridge and the top out spring from the rod.



Move the circlip holding the bottom out cone, slide it approximately 1-2" down the shaft being careful not to scratch the shaft.

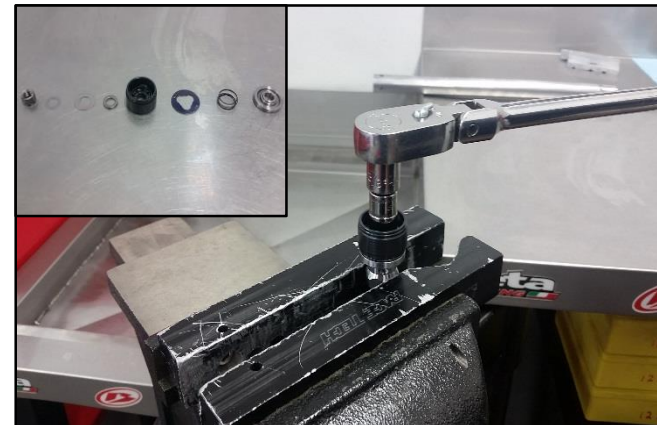

Remove the 11mm nut from the rebound assembly. Remove the rebound assembly paying attention to order and shim orientation. Clean and inspect all parts for wear or damage.

Rebound



Reinstall the spring seat.

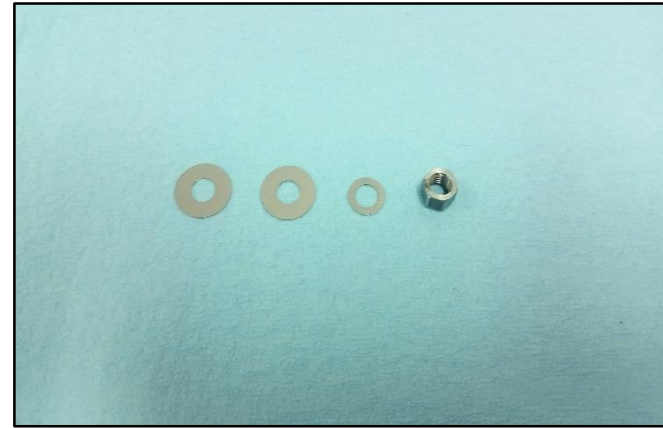

Reinstall the spacer and shim stack.

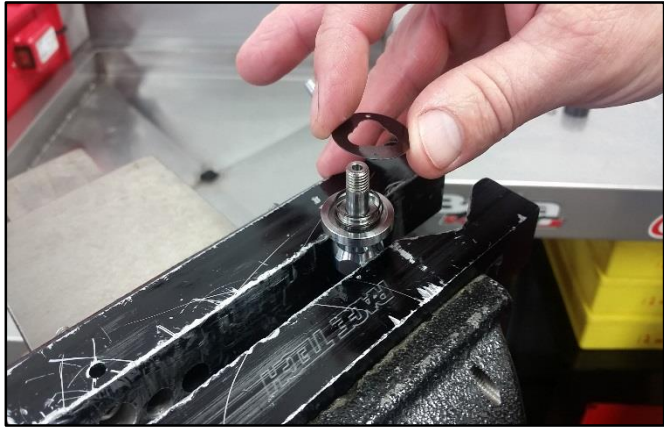

Reinstall the spring and check plate.



Put a drop of high strength thread locking agent on the nut and tighten to 10Nm.



Reinstall the piston.

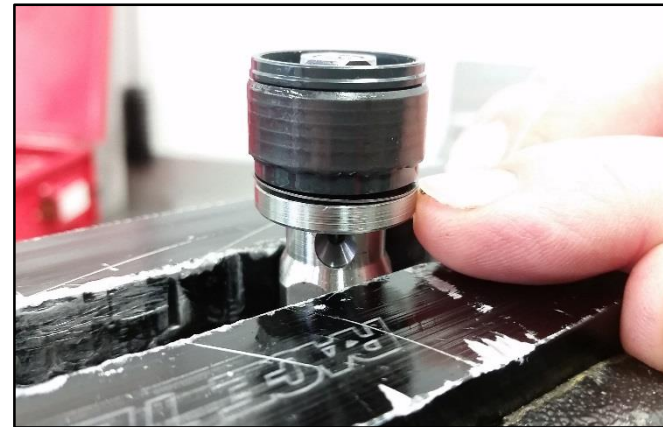

Make sure the check plate floats freely.



Secure the base valve in the soft jaw vise.

Base Valve



Reinstall the piston.



Remove the nut and the rest of the assembly paying attention to the order and orientation. Thoroughly clean and inspect all parts for wear and damage.

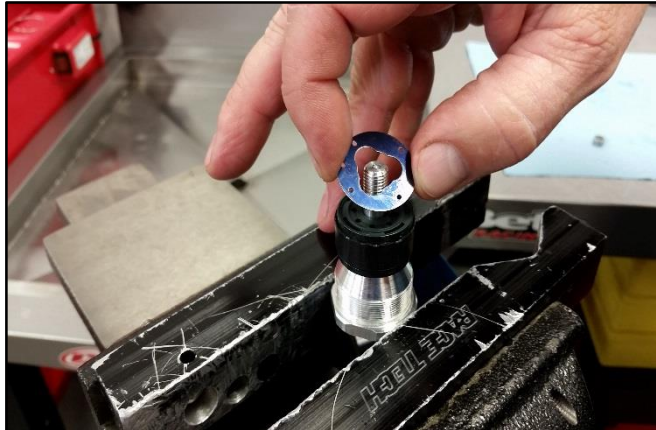

Reinstall the check plate.

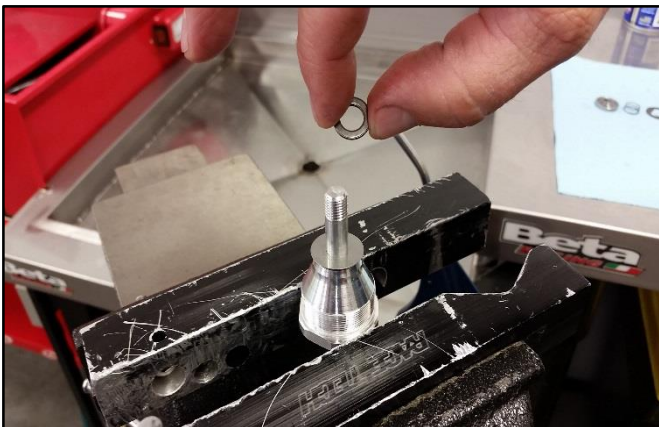

Reinstall the shim stack and spacer.



Reinstall the spring and spring seat.



Apply high strength thread locking agent to the nut threads and tighten to 10Nm. Make sure the check plate floats freely.

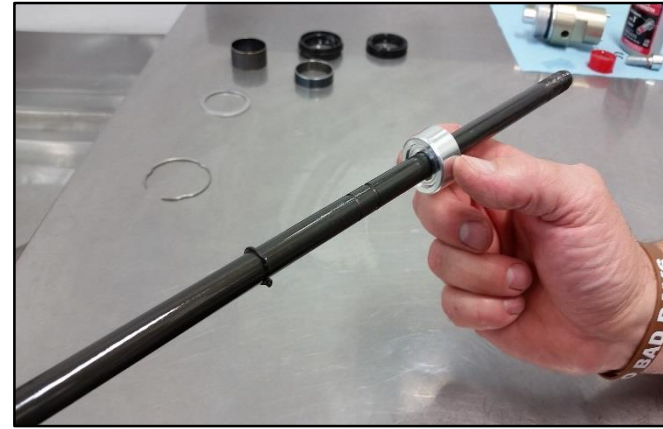

Reinstall the bottom out cone.



Reinstall the top out spring on the damping rod. Apply fork oil to the piston band and apply grease to the rod threads. Insert damping rod into cartridge.



Apply a high quality grease to the retaining ring groove to hold the 2 piece ring in place.



Reinstall the circlip 1-2" passed it's groove being careful not to scratch the shaft.



Slide the bottom out cone into position then carefully slide the circlip into place making sure it is fully seated into the groove.



Apply oil to the base valve piston seal.

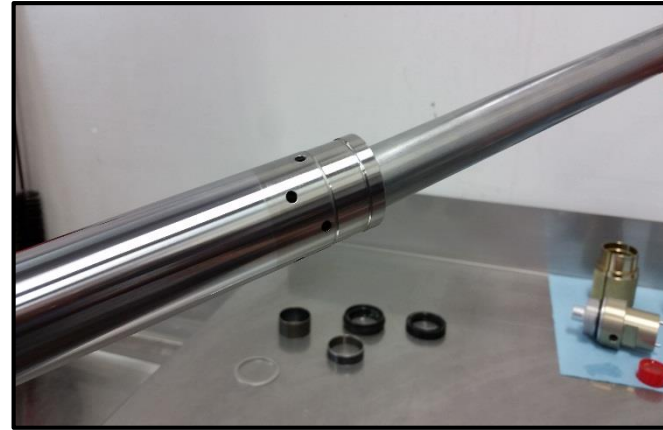

Insert the cartridge into the lower fork leg.



Apply high strength thread locking agent to the base valve threads.



Insert the 10mm Allen bolt and copper washer and torque to 40Nm.



Reinstall the base valve into the cartridge and torque to 30Nm.



Grease and install the rebound adjuster rod.

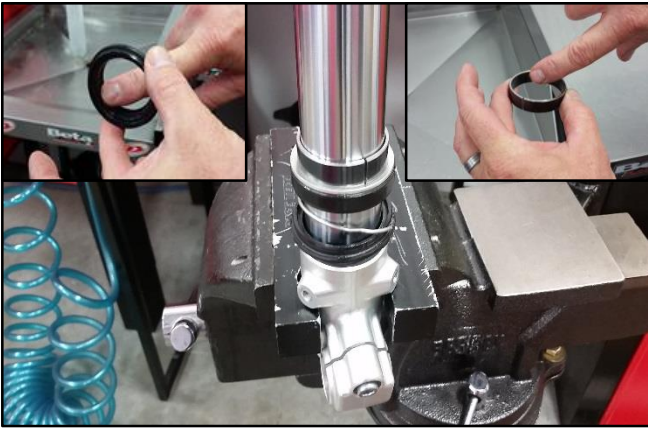

Apply a high quality seal or O-ring grease to the fork and dust seal and apply fork oil to both sides of the bottom guide bushing. Install the bushing, seals and clip on the lower leg in the correct order and orientation.

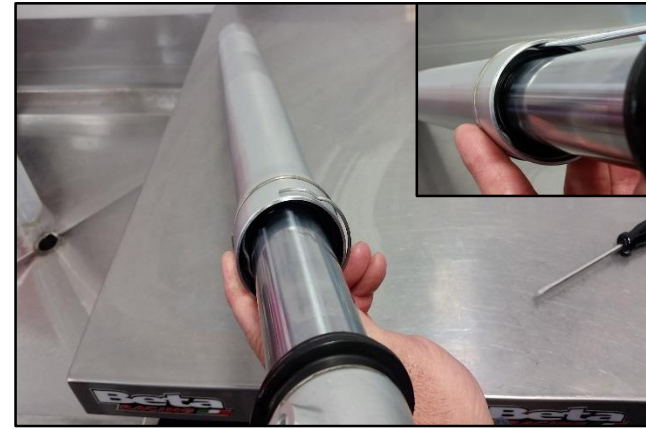

Insert the oil seal retainer clip making sure it is fully seated.



Apply fork oil to both sides of the top guide bushing then install it on the inner fork tube. Carefully slide the outer fork tube on to the lower tube.



Slide the outer leg down all the way to the axle lug to seat the dust seal.



Use a seal driver to install the seal and lower guide bushing.



Fill the fork with high quality 5w fork oil to 500cc. Stroke the damping rod up and down to remove air from the cartridge.

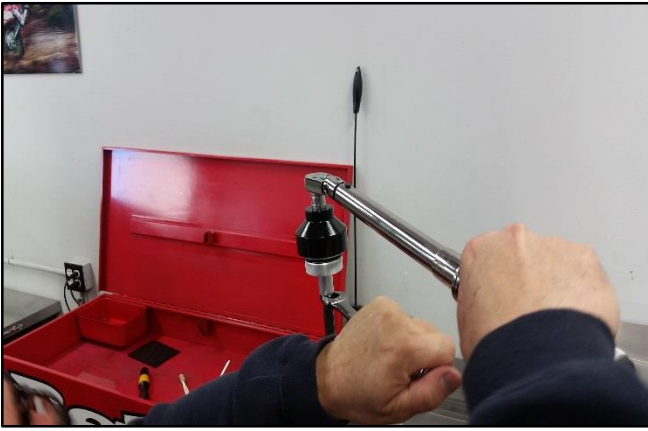

Screw on the fork cap until it bottoms out. Run the nut up to the cap and tighten to 16Nm.



Pull the outer leg up and tighten the fork cap to 10Nm.