



ZF Sachs 48mm Open Cartridge Fork Service Manual
2020 – 2023 SFF Fork Disassembly and Assembly
ZF Sachs Fork Lowering

CONFIDENTIALITY NOTICE

This message (including any attachments) contains information that may be confidential and is for authorized Beta Dealer's use only.

7-2019

Work must be performed by trained technician.
Beta USA, Inc.

Table of Contents

Introduction / Special Tools	Page 2
20-21' Fork Diagram and Component Description.....	Page 3-4
20-21' RH Fork (Spring side) Disassembly.....	Page 5
20-21' LH Fork (Dampening) Disassembly.....	Page 6
20-21' Fork Internal Disassembly.....	Pages 7-11
20-21' Fork External Disassembly.....	Page 12
20-21' Fork External Assembly.....	Page 13-15
20-21' Fork Internal Assembly.....	Pages 16-22
20-21' Oil Fluid Refill Procedure.....	Page 21-22
20-21' Fork Cap & Spring Installation.....	Page 22-23
20-21' Fork Lowering Spacer Procedure.....	Pages 24-26

Introduction

2020-21' Model: The SFF or Single Function Fork refers to each fork having a specific duty. The non brake side (right) fork utilizes an external spring preload adjustment and compression dampening. The brake side (left) fork is the rebound dampening.

Both fork internal components look very similar, but they are specific to one side of the fork. Therefore, it is advised not to combine them during disassembly, cleaning, or assembly.

The procedures in this manual require a qualified technician, suspension knowledge and specific suspension tooling..

Use caution not to damage the surface of the fork tubes, cartridge, rod, or any other suspension components.

When using a the bench vise, always use protective jaws made from brass, aluminum or plastic. Always clean suspension components before assembly, using appropriate solvents and lint free towels to prevent contamination. Replace all common wear parts such as seals, gaskets, bushings and O-rings every service interval.

CAUTION:

Always wear protective eyewear, gloves and appropriate clothing. Before you perform any maintenance, be sure to read and carefully follow the detailed instructions described in this manual.

Incorrect disassembly/assembly of the fork may cause serious damage, injury, or death to the rider and property.

Special tools

1. 17 mm allen Socket
2. 19 mm low torque wrench
3. 19 mm low torque wrench
4. Cartridge rod holding clamp
5. Oil level syringe
6. 45 degree pick
7. 48mm seal driver
8. 48mm seal bullet
9. Fork cap wrench
10. Measuring beaker



2020-21' Left Fork (SX) Diagram and Component Description

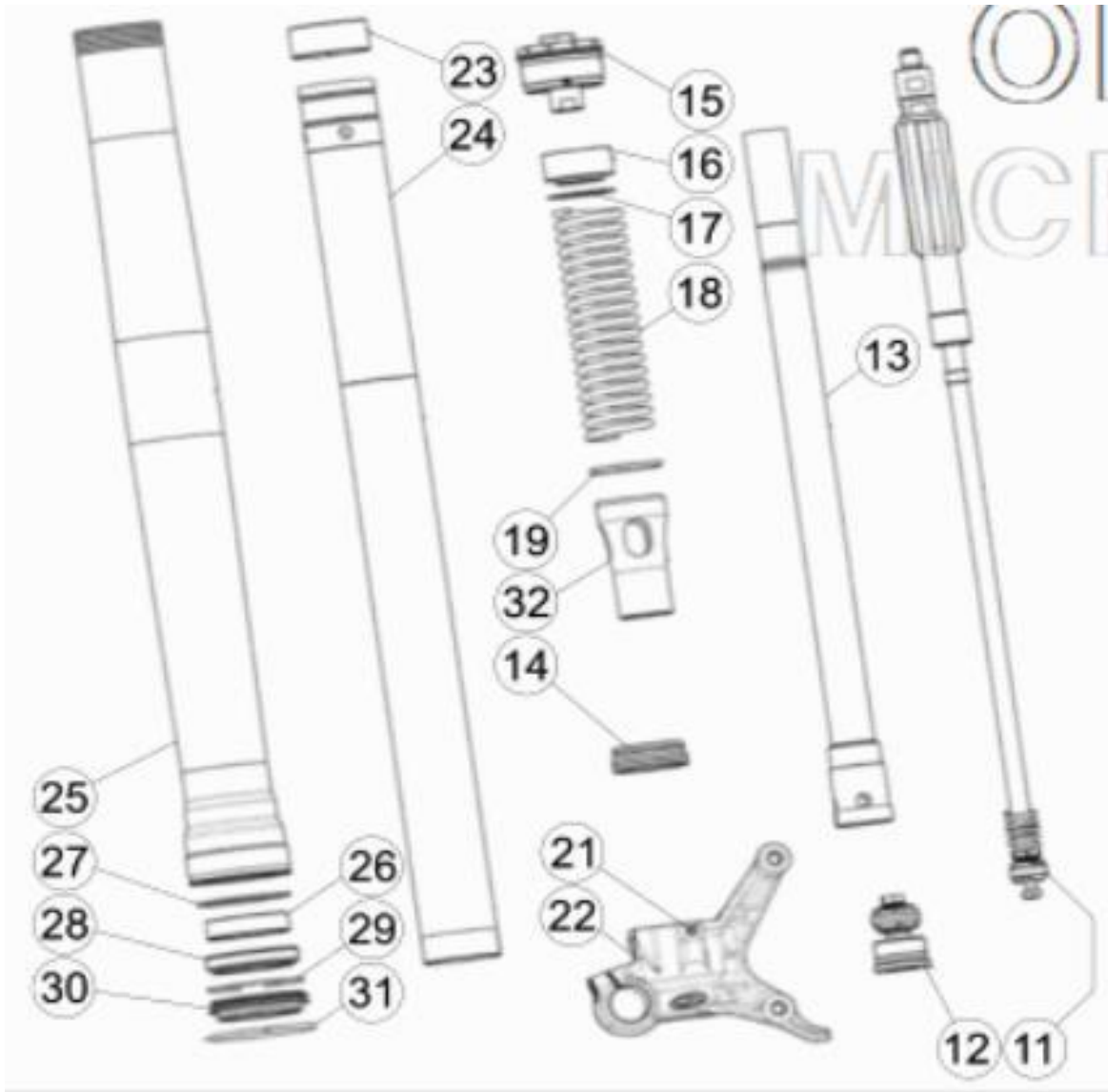

- | | |
|-----------------------------------|---------------------------------|
| 11. Cartridge Rod Assembly – REB. | 23. Slide Bushing |
| 12. Base Valve Assembly – REB. | 24. Inner Tube Assembly |
| 13. Cylinder Assembly – REB. | 25. Outer Tube Assembly |
| 14. Aluminum Centering Collar | 26. Guide Bushing |
| 15. Fork Cap Assembly – REB. | 27. Oil Seal Support Washer |
| 16. Delrin Spacer | 28. Oil Seal |
| 17. Steel washer | 29. Oil Seal Retaining Cir-clip |
| 18. Fork Spring | 30. Dust Wiper Seal |
| 19. Steel Ring Seat | 31. Outer Tube Wear Ring |
| 21. Set Screw | |
| 22. Axle Carrier | |

2020-21' Right Fork (DX) Diagram and Component Description

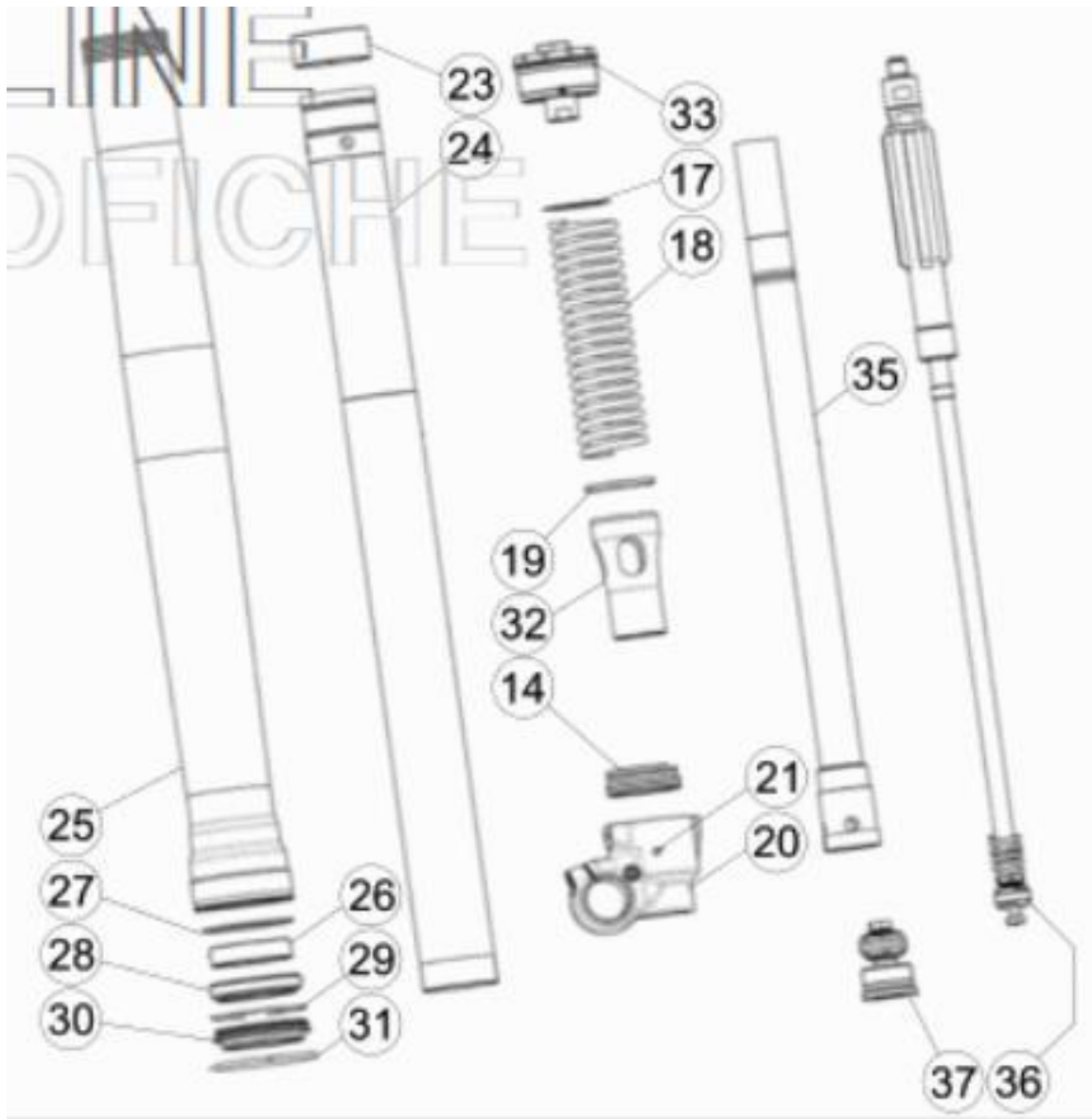

- 14. Cylinder support collar
- 17. Steel Washer
- 18. Fork Spring
- 19. Steel Ring Seat
- 20. Axle Carrier
- 21. Set Screw
- 23. Slide Bushing
- 24. Inner Tube Assembly
- 25. Outer Tube Assembly
- 26. Guide Bushing
- 27. Oil Seal Support Washer

- 28. Oil Seal
- 29. Oil Seal Retaining Cir-clip
- 30. Dust Seal
- 31. Outer Tube Wear Ring
- 32. Spring Perch
- 33. Fork Cap Assembly – COMP/PLD
- 35. Cylinder Assembly – COMP.
- 36. Cartridge Rod Assembly
- 37. Base Valve Assembly – COMP.

20-21' Right Fork Cap Disassembly

Compression and Spring Preload

**Note the adjustment settings then back out all adjusters completely.*



Secure the fork in a soft jaw vise and loosen the cap from the outer fork tube with the 10Pt. wrench (AB-15021).

Identify the non brake side bottom base valve compression assembly using a paint marker, or equivalent.



Pull downward on the fork spring and insert a 19mm low torque (thin) wrench onto the **spring guide nut**. Next, insert a 19mm low torque wrench above the spring guide nut, located on the lower part of the fork cap.

Hold the lower 19mm wrench and turn the top 19mm wrench counter clockwise to break free the fork cap assembly from the spring guide nut.

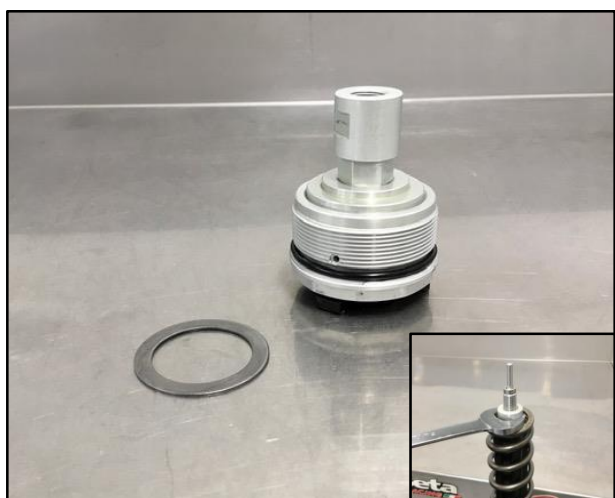

20-21' Right Fork Cap
(Compression/Preload) * Shown in photo

20-21' Left Fork Cap Disassembly

Rebound Dampening

**Note the adjustment settings then back out all adjusters completely.*

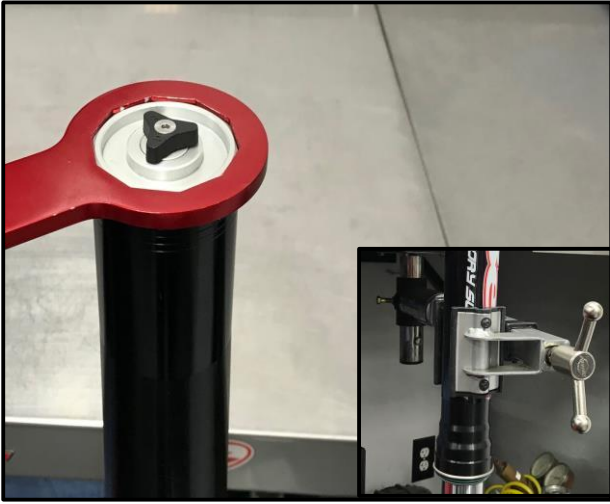

Secure the fork in a soft jaw vise or Park tool and loosen the cap from the outer fork with the 10Pt. wrench (AB-15021).



Pull downward on the fork spring and insert a 19mm low torque (thin) wrench onto the **spring guide nut**.

While holding the spring guide jam nut with the 19mm wrench, loosen and remove the fork cap with the 10pt. fork cap wrench counter-clockwise.



20-21' Left Fork Cap (Rebound)

* Shown in photo

20-21' Fork Internal Disassembly



Remove the fork spring.



Drain the fork oil.



Remove the thin aluminum rebound push rod.

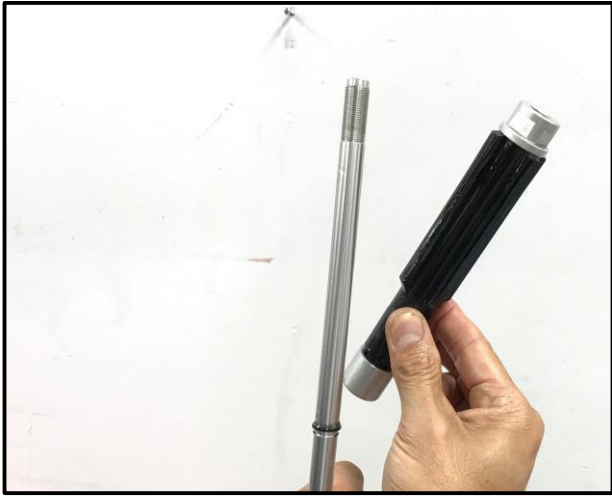

Remove the spring guide.



Note: Inspect the spring guide for damage. If the spring guide is fractured, or cracked a new spring guide is available from the 2019 RR-S parts diagram.

Part # 031-340860-000



The 20-21' spring guide comes with two small bleed holes. It is recommended to enlarge each hole to 3mm. The modified spring guide is on the right side.

*** If the O-ring is damaged, it can be removed if the 3mm enlarged holes are implemented.**





If the spring perch was removed when draining out the fluid, re-install the perch in the direction it was first removed.

Re-install the fork spring and apply downward pressure to keep the cartridge cylinder bottomed for the base valve assembly removal.

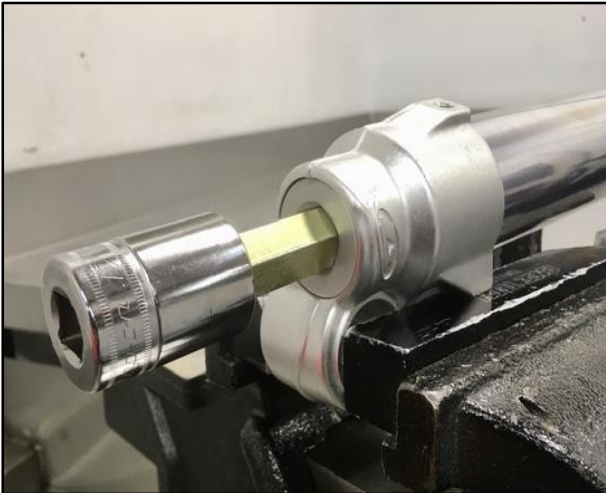

Install the 17mm allen socket into the bottom of the base valve assembly.

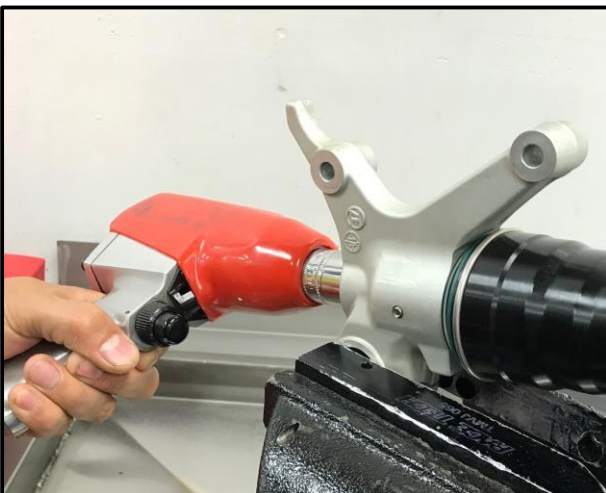

Use an impact wrench, or ratchet with the 17mm allen socket to loosen the base valve assembly.



Remove the base valve assembly from cartridge cylinder and bottom of fork external.

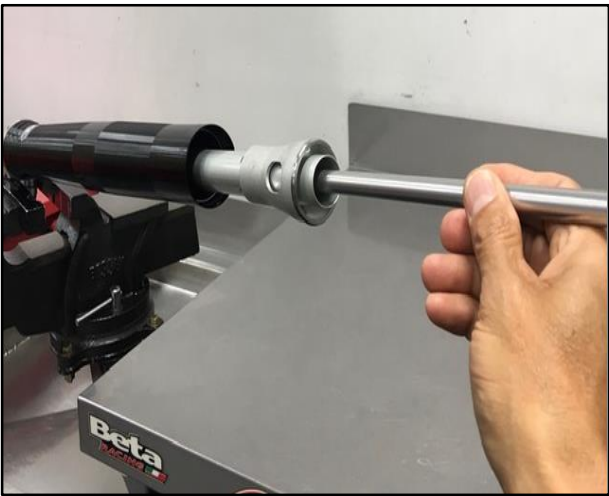

Remove the cartridge assembly from the outer fork external assembly.

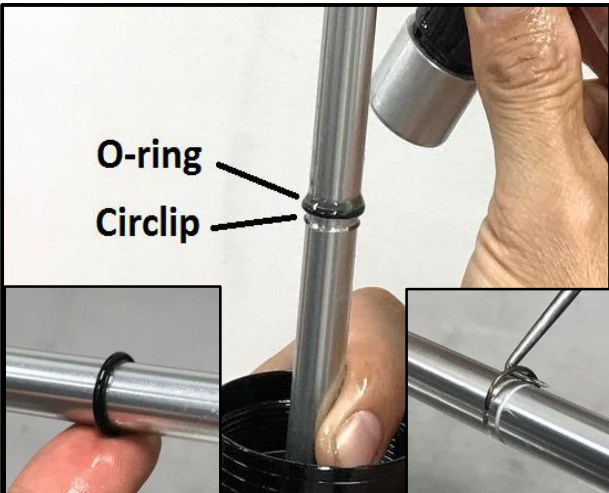

*** 2020 model displayed ***

Remove O-ring and cir-clip below



*** Early 2021 model displayed ***

Some early 2021 models will have (2) circlip grooves. Only the **TOP** groove will be utilized for the cir-clip position and the lower groove will not be used.

The 2021 spring guide has a new design with the O-ring inside.



*** Later 2021 model displayed ***

Later 2021 models will have only (1) cir-clip groove.

The 2021 spring guide has a new design with the O-ring inside.



Remove the cartridge rod assembly from the cartridge cylinder.

Clean and inspect all parts.

Note: FOR FORK LOWERING, now proceed to pages 24-26

Fork External Disassembly

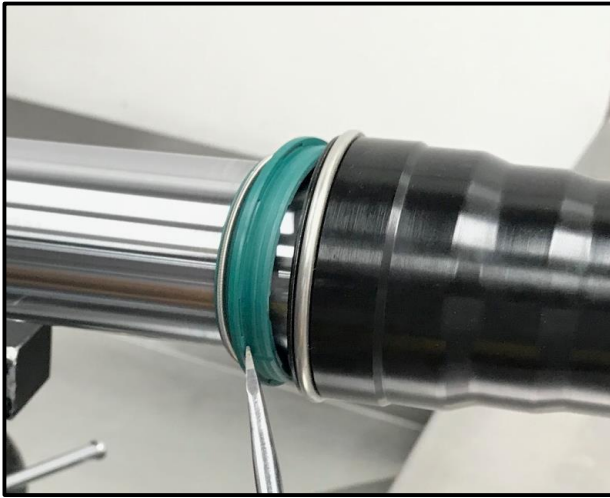

Using a flathead screwdriver, remove the dust seal away from the outer fork tube.



Remove the oil seal circlip with a 45 degree pick.

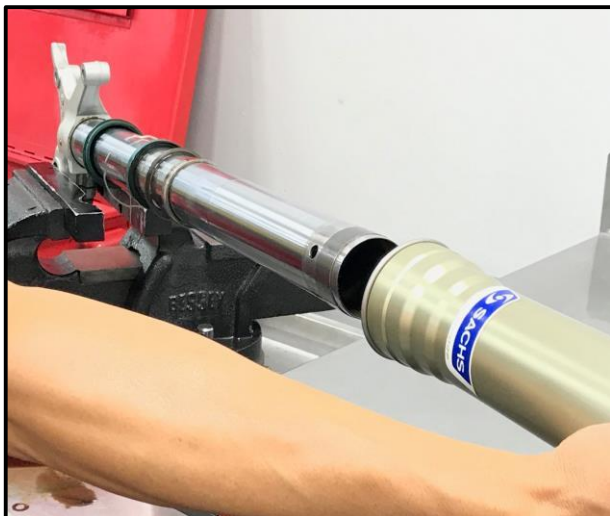

At this time, the axle carrier should be secured in a bench vice. Next, pull the outer tube quickly away from the inner tube assembly.

Remove the bushings, oil seal washer, oil seal, retaining circlip and dust seal. Note the order of orientation before removal.

Clean and inspect all components, replace all common wear parts.

Fork External Assembly



Use 600 grit wet/dry sandpaper with a twisting motion back and forth to clean up any nick's, or burrs on the outside of the inner fork tube.



Apply grease to the inside surface of the new dust seal and inner and outer area of the oil seal.

Using a 48mm fork seal bullet, install the dust seal, circlip , oil seal and support washer in this orientation.



Remove the seal bullet and install the new slide and guide bushing.

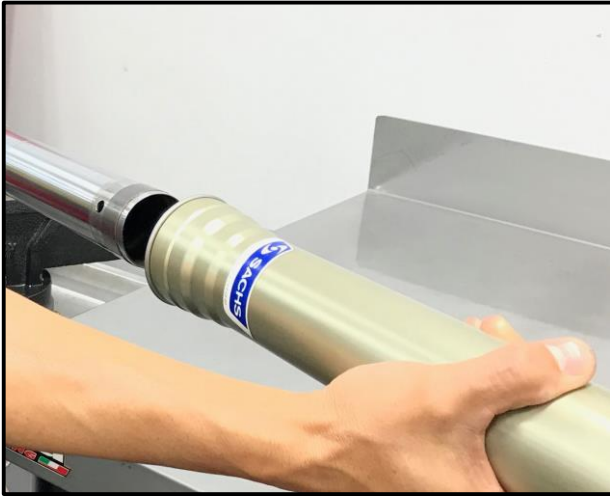

Slide the outer fork tube over the slide bushing, located on the inner tube.



Using a 48mm seal driver, slide the support washer against the slide bushing to install it into the outer fork leg.



Use the seal driver to insert the oil seal into the outer fork tube.



Insert the oil seal retaining circlip making sure it is fully seated into the groove.



Push the outer fork tube against the axle carrier until the dust seal is completely seated.

2020-21' Cartridge Assembly



Wrap the Teflon Z band around a screwdriver.

Wrapping it in a tight spiral before installing will help keep it on the rebound piston during installation.



Install the Teflon Z band around the valve.



The 20-21' **rebound** rod assembly utilizes delta valve shims (**triangular shims**) located on the top of the valve. Reference for the rebound cartridge rod.

(**Right photo**)

The 20-21' **compression** rod assembly has one check shim and spring located on top of the valve with **NO** triangular shims.

Reference for the compression cartridge rod.

(**Left photo**)



The 20-21' cartridge cylinders are specific for each fork leg.

**Compression Cylinder: HOLES
DRILLED**

Rebound Cylinder: NO HOLES



Insert the **Rebound cartridge rod (triangular shims)** assembly into the cartridge cylinder (**NO HOLES**).

Insert the **Compression cartridge rod (NON triangular shims)** assembly into the cartridge cylinder (**WITH HOLES**)



2020:

Install the circlip onto the cartridge rod.

Apply grease to the O-ring groove and install onto the cartridge rod.

Circlip position is the bottom groove and the O-ring is for the top groove.



2021: O-ring non applicable

Early 21' models: Circlip position is the top groove, disregard the bottom groove.

Later 21' models: Only one circlip groove

The 21' spring guide has an integrated O-ring inside of the spring guide.



Apply grease to the threads inside the cartridge cylinder.

Apply grease to the threads and piston O-ring on the compression adjuster assembly.

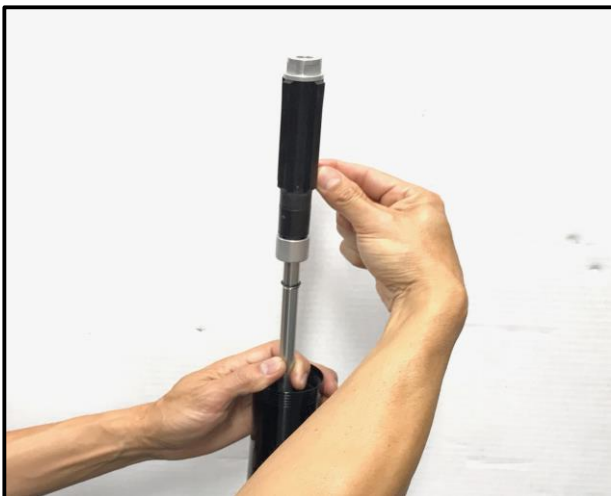

Thread the spring guide onto the cartridge rod, until completely bottomed.

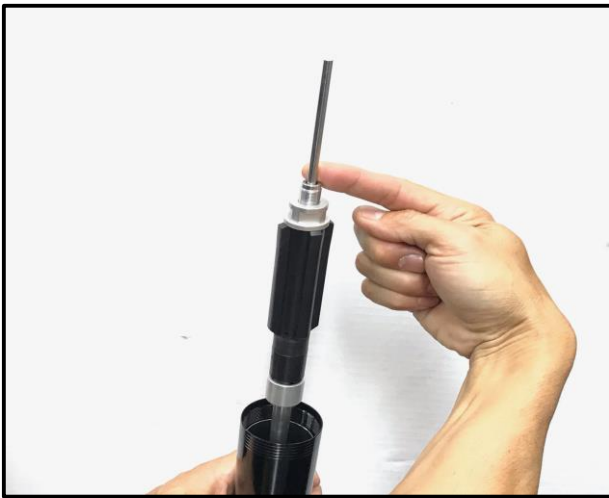

Install the aluminum rebound push rod inside the cartridge rod.

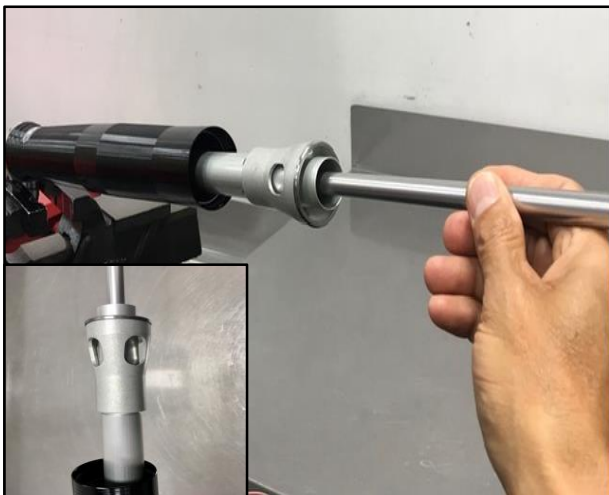

Insert the specific cartridge assembly into the correct fork external with spring perch installed in the correct direction.

Brake Side = REBOUND DAMPENING.

Non Brake Side = COMPRESSION DAMPENING / SPRING PRE-LOAD

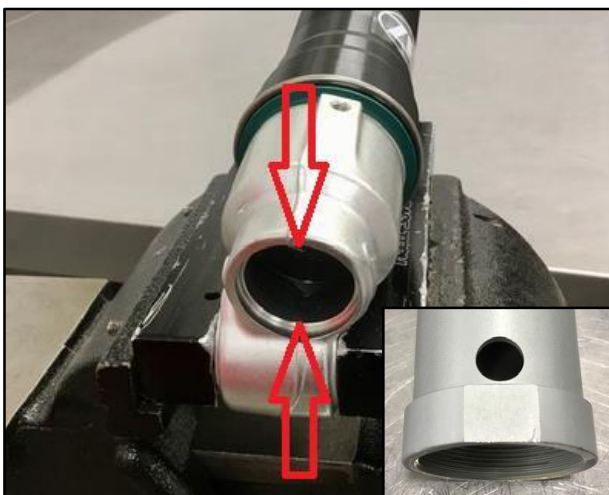

Note: Red arrows indicate flat surface areas inside the axle carrier.

The bottom of the cartridge cylinder has flat surface areas across from each other. These flat areas of the cartridge cylinder seat inside the axle carrier to keep the cylinder from turning.



With the cartridge assembly installed, apply downward pressure on the fork spring and spring perch. This will assure the cartridge cylinder is bottomed for the base valve assembly.



Check visually to assure the cylinder is seated inside the axle carrier. See the red arrow picture above.

Insert the greased compression assembly into the bottom of the fork leg.

Thread the assembly by hand into the cylinder to prevent thread galling.

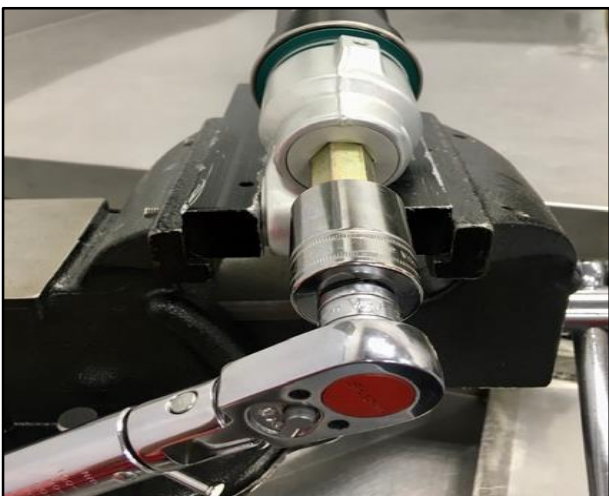

Tighten the compression assembly and torque to 35Nm.

Oil Fluid Refill Procedure

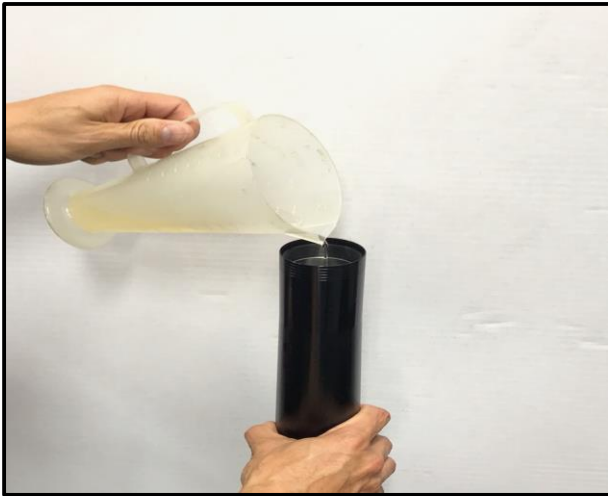

With the fork outer tube completely collapsed, fill the inner fork tube and cartridge assembly with 5 wt. fork fluid.

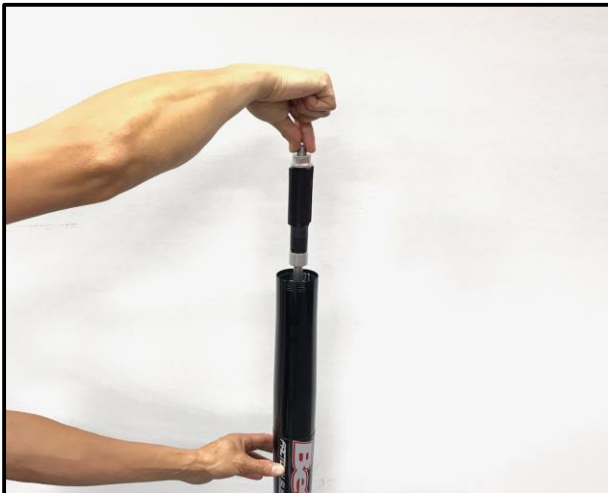

Cycle the cartridge rod up and down, until the cartridge rod has no apparent free spots and the fork fluid has no air bubbles rising to the surface.



Using a fork oil level gauge, set to the desired air space level inside the inner fork tube.

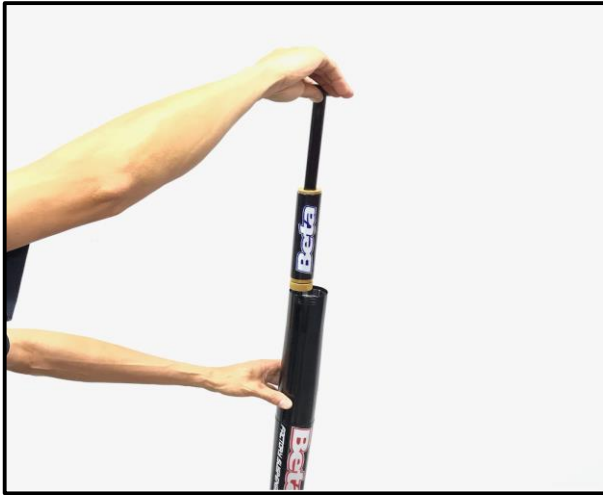

With the outer fork tube and cartridge rod bottomed, remove the excess fork fluid using the fork oil level tool.

****Recommended air space levels ****

Soft = 110mm

Comfort = 100mm

Sport = 90mm

Fork Cap & Spring Installation



Install fork spring.

Suggestion: If spring has an engraved rate on it, install the rate facing upwards to help determine the spring rate without having to remove the spring.



Once the fork spring has been installed over the spring guide, insert the 19mm low torque wrench and rotate the fork spring downward for easy installation.



20-21' Rebound Fork Cap (Brake Hanger Side)

Pull downward on the fork spring, insert the 19mm wrench onto the spring guide nut.

Install the fork cap and thread clockwise until completely bottomed. A gap between the guide nut and cap should be visual.

Tighten the 19mm spring guide nut to fork cap using the 10 pt. wrench until secure.



20-21' Compression Fork Cap / Pre-Load

Pull downward on the fork spring, insert the 19mm wrench onto the spring guide nut.

Install the fork cap and thread clockwise until completely bottomed. A gap between the guide nut and cap should be visual.

Tighten the 19mm spring guide nut and 19mm fork cap nut until secure.



Thread the fork cap into the fork outer tube and hand tighten with fork cap wrench.

Loc-tite should NEVER be used to adhere the fork cap to outer fork tube!!

Fork Lowering Procedure



Lowering spacer placement on the cartridge rod.



1. Follow the fork disassembly procedures on pages 5-12.



2. Wrap the cartridge rod with paper and secure the rod with a cartridge rod holding clamp. Secure holding clamp with a soft jaw vise.

Fork Lowering Procedure

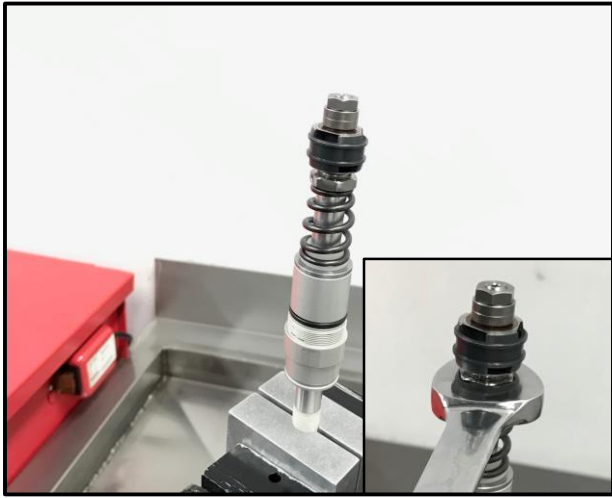

3. Use a 17mm wrench to unthread the rebound piston assembly from the cartridge rod.



4. Remove the rebound piston assembly from the cartridge rod.



5. Remove the top out spring from the cartridge rod and remove the plastic spring seat (white plastic) from the top-out spring.

(Continued)

Fork Lowering Procedure



6. Use a bench vise to press the lowering spacer into the top out spring.

The lowering spacer with the shoulder end installs inside the top-out spring.



7. Install the lowering spacer with top-out spring assembly onto the cartridge rod. The smaller end of the spring should face upwards.

Apply a high strength thread locking agent (Red) to the threads on the rebound assembly.



8. Tighten the rebound assembly, but be careful not to overtighten.

9. Proceed to pages 16-22 for reassembly procedures.